

ROBONETICS™

USER'S MANUAL

ITEM NO. 8095

AGES: 8+

WWW.ROBORAPTORONLINE.COM



ROBORAPTOR™

A FUSION OF TECHNOLOGY AND PERSONALITY





TABLE OF CONTENTS

• ROBORAPTOR™ OVERVIEW	1
• CONTROLLER INDEX	2
• BATTERY DETAILS	3
• BASIC OPERATION	4
• ADVANCED OPERATION	5
FREE-ROAM & GUARD MODES	5
“LASER” TARGETING & CONTROLLING ROBORAPTOR™’S MOODS	6
TOUCH SENSORS	7
SOUND & VISION SENSORS	8
OBSTACLE AVOIDANCE	9
• UNDERSTANDING YOUR ROBORAPTOR™	9



ROBORAPTOR™ OVERVIEW

ROBORAPTOR™

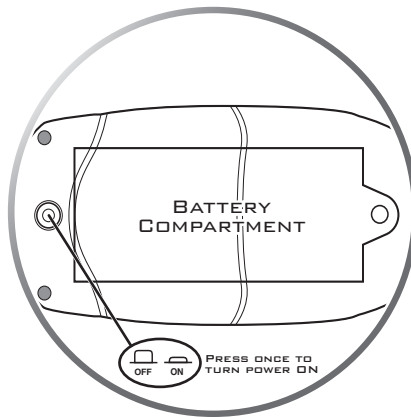
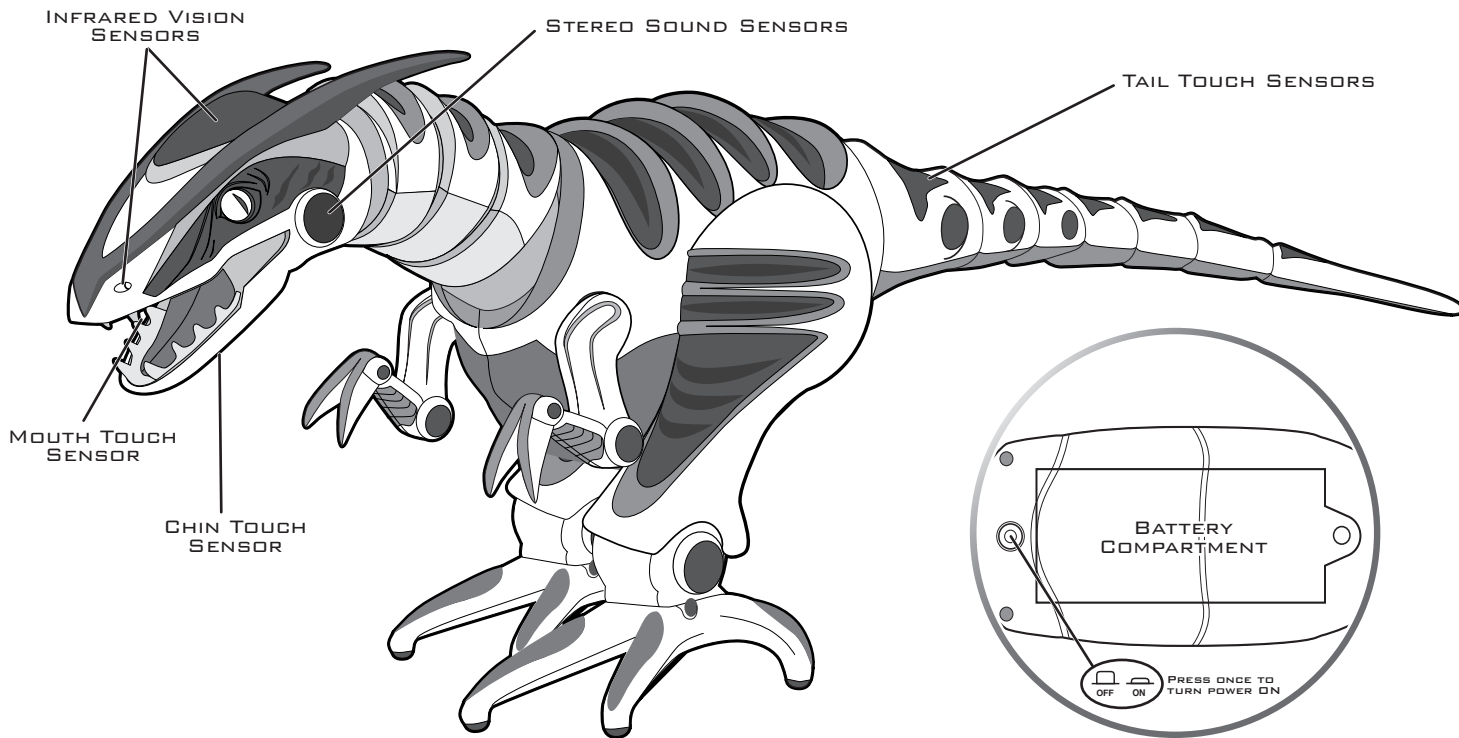

BOTTOM VIEW



CONTROLLER INDEX

REMOTE CONTROLLER

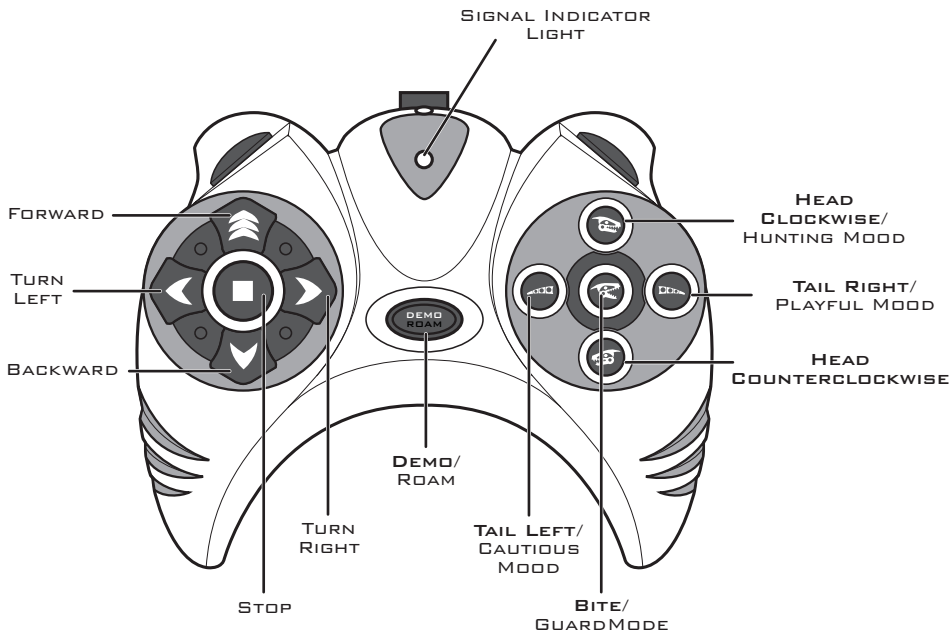

FRONT VIEW

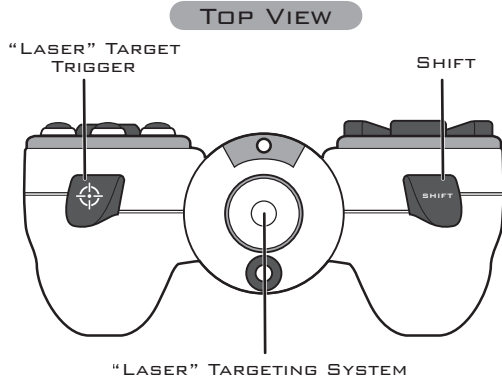

TOP VIEW

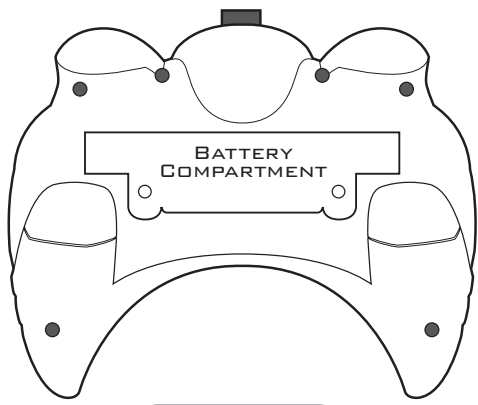

BACK VIEW



BATTERY DETAILS

BATTERY REQUIREMENTS:

YOUR ROBORAPTOR™ IS POWERED BY 6 X “AA” SIZE BATTERIES (NOT INCLUDED).

YOUR REMOTE CONTROLLER IS POWERED BY 3 X “AAA” SIZE BATTERIES (NOT INCLUDED).

BATTERY INSTALLATION:

1. BEFORE INSTALLING OR CHANGING BATTERIES, ENSURE THE ROBORAPTOR™’S **ON/OFF** BUTTON IS IN THE **OFF** POSITION.
2. REMOVE THE BATTERY COMPARTMENT COVERS USING A PHILLIPS OR CROSSHEAD SCREWDRIVER (NOT INCLUDED).
3. INSERT BATTERIES (NOT INCLUDED) INTO THE ROBORAPTOR™ AND CONTROLLER AS SHOWN IN THE DIAGRAMS.
4. REPLACE THE BATTERY COMPARTMENT COVERS AND THE SCREWS.

ATTENTION: IMPORTANT BATTERY INFORMATION

- USE ONLY FRESH BATTERIES OF THE REQUIRED SIZE AND RECOMMENDED TYPE.
- DO NOT MIX OLD AND NEW BATTERIES, DIFFERENT TYPES OF BATTERIES (STANDARD (CARBON ZINC), ALKALINE, OR RECHARGEABLE), OR RECHARGEABLE BATTERIES OF DIFFERENT CAPACITIES.
- REMOVE RECHARGEABLE BATTERIES FROM THE TOY BEFORE RECHARGING THEM.
- RECHARGEABLE BATTERIES ARE ONLY TO BE CHARGED UNDER ADULT SUPERVISION.
- PLEASE RESPECT THE CORRECT POLARITY, (+) AND (-).
- DO NOT TRY TO CHARGE NON-RECHARGEABLE BATTERIES.
- DO NOT THROW BATTERIES INTO THE FIRE.
- REPLACE ALL BATTERIES OF THE SAME TYPE/BRAND AT THE SAME TIME.
- THE SUPPLY TERMINALS ARE NOT TO BE SHORT CIRCUITED.
- REMOVE EXHAUSTED BATTERIES FROM THE TOY.
- BATTERIES SHOULD BE REPLACED BY ADULTS BECAUSE OF SMALL PARTS.
- REMOVE BATTERIES IF THE TOY IS NOT GOING TO BE PLAYED WITH FOR SOME TIME.
- THE PACKAGING HAS TO BE KEPT SINCE IT CONTAINS IMPORTANT INFORMATION.

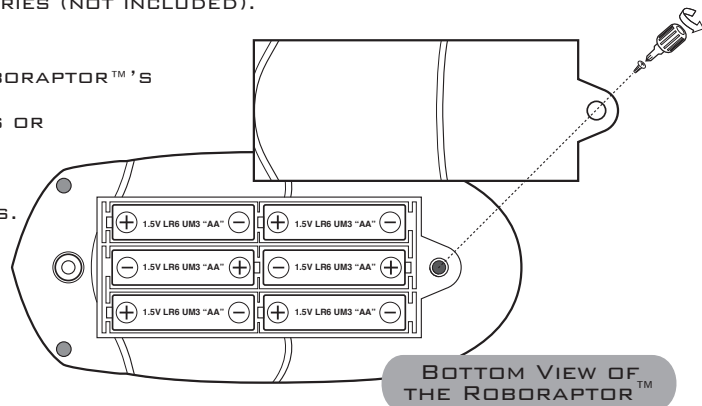

BOTTOM VIEW OF THE ROBORAPTOR™

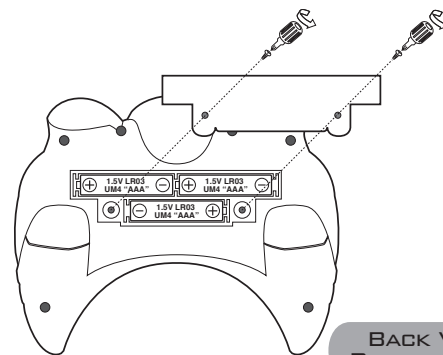

BACK VIEW OF THE REMOTE CONTROLLER



BASIC OPERATION

TURN ON ROBORAPTOR™ USING THE ON/OFF BUTTON (REFER TO PAGE 1 “ROBORAPTOR™ OVERVIEW”).

ROBORAPTOR™ CAN BE CONTROLLED DIRECTLY USING THE BUTTONS ON THE REMOTE CONTROLLER.

THESE INSTRUCTIONS ASSUME THAT YOU AND THE ROBORAPTOR™ ARE FACING EACH OTHER.

- **HUNTING GAIT**  x1: PUSH “FORWARD” ONCE TO MAKE ROBORAPTOR™ MOVE FORWARD USING HIS SLOW PREDATORY HUNTING WALK.
- **WALKING GAIT**  x2: WHILE ROBORAPTOR IS MOVING FORWARD IN HIS HUNTING GAIT, PUSH “FORWARD” AGAIN TO MAKE ROBORAPTOR™ MOVE FORWARD USING HIS NORMAL WALKING SPEED.
- **RUNNING GAIT**  x3: WHILE ROBORAPTOR IS MOVING FORWARD IN HIS WALKING GAIT, PUSH “FORWARD” AGAIN TO MAKE ROBORAPTOR™ MOVE FORWARD USING HIS RUNNING TOP SPEED.
- **BACKWARD**  x1: PUSH “BACKWARD” TO MAKE ROBORAPTOR™ MOVE BACKWARD.
- **TURN LEFT**  x1: PUSH “TURN LEFT” ONCE TO MAKE ROBORAPTOR™ TURN LEFT IN PLACE (FROM YOUR POINT OF VIEW).
- **TURN RIGHT**  x1: PUSH “TURN RIGHT” ONCE TO MAKE ROBORAPTOR™ TURN RIGHT IN PLACE (FROM YOUR POINT OF VIEW).
- **WALK LEFT**  x2: WHILE ROBORAPTOR™ IS TURNING LEFT, PUSH “TURN LEFT” AGAIN TO MAKE ROBORAPTOR™ WALK A WIDE ARC TO THE LEFT (FROM YOUR POINT OF VIEW).
- **WALK RIGHT**  x2: WHILE ROBORAPTOR™ IS TURNING RIGHT, PUSH “TURN RIGHT” AGAIN TO MAKE ROBORAPTOR™ WALK A WIDE ARC TO THE RIGHT (FROM YOUR POINT OF VIEW).
- **STOP**  : PUSH “STOP” TO MAKE ROBORAPTOR™ STOP WHATEVER HE IS DOING.
- **HEAD CLOCKWISE**  : PUSH “HEAD CLOCKWISE” TO MAKE ROBORAPTOR™ ROTATE HIS HEAD IN A CLOCKWISE DIRECTION (FROM YOUR POINT OF VIEW). PRESS THE BUTTON FOUR TIMES TO COMPLETE A FULL ROTATION.
- **HEAD COUNTERCLOCKWISE**  : PUSH “HEAD COUNTERCLOCKWISE” TO MAKE ROBORAPTOR™ ROTATE HIS HEAD IN A COUNTERCLOCKWISE DIRECTION (FROM YOUR POINT OF VIEW). PRESS THE BUTTON FOUR TIMES TO COMPLETE A FULL HEAD ROTATION.
- **TAIL LEFT**  : PUSH “TAIL LEFT” TO MAKE ROBORAPTOR™ MOVE HIS HEAD AND TAIL TO THE LEFT (FROM YOUR POINT OF VIEW).
- **TAIL RIGHT**  : PUSH “TAIL RIGHT” TO MAKE ROBORAPTOR™ MOVE HIS HEAD AND TAIL TO THE RIGHT (FROM YOUR POINT OF VIEW).
- **BITE**  : PUSH “BITE / GUARD MODE” TO MAKE ROBORAPTOR™ PERFORM A BITE.
- **DEMO**  : PUSH “DEMO / ROAM” TO MAKE ROBORAPTOR™ PERFORM A DEMO SEQUENCE.



ADVANCED OPERATION

FREE-ROAM MODE

ROBORAPTOR™ WILL START TO EXPLORE HIS ENVIRONMENT AUTONOMOUSLY IN FREE-ROAM MODE IF LEFT ALONE FOR MORE THAN THREE MINUTES.

CAUTION: [DO NOT PUT HIM NEAR THE EDGE OF A TABLE SINCE HE COULD FALL OFF WHEN HE BECOMES ANIMATED.]

YOU CAN ALSO PUT ROBORAPTOR™ INTO FREE-ROAM MODE MANUALLY BY PRESSING “SHIFT” AND “DEMO / ROAM” .



WHILE ROBORAPTOR™ IS IN FREE-ROAM MODE HE WILL AVOID OBSTACLES USING HIS INFRARED VISION SENSORS. OCCASIONALLY HE WILL STOP MOVING TO SEE IF HE CAN HEAR ANY SHARP, LOUD SOUNDS. (SEE “STEREO SOUND SENSORS” ON PAGE 8)

IF YOU TRIGGER ANY OF ROBORAPTOR™’S TOUCH SENSORS OR PRESS A BUTTON ON THE CONTROLLER, ROBORAPTOR™ WILL EXIT FROM FREE-ROAM MODE.

AFTER 5 TO 10 MINUTES OF EXPLORATION ROBORAPTOR™ WILL POWER DOWN. TO WAKE HIM UP PRESS THE ON/OFF BUTTON TWICE.

NOTE: BUTTONS FOR “LASER” TARGET TRIGGER AND SHIFT WILL NOT STOP ROBORAPTOR™ FROM IT’S FREE-ROAM MODE.

GUARD MODE

PRESS “SHIFT” AND “BITE / GUARD” MODE TO PUT ROBORAPTOR™ INTO GUARD MODE.



ROBORAPTOR™ WILL PERFORM A HEAD ROTATION TO CONFIRM THAT HE IS IN GUARD MODE.

IN GUARD MODE ROBORAPTOR™ IS USING HIS INFRARED VISION SENSORS AND STEREO SOUND SENSORS TO GUARD THE AREA IMMEDIATELY AROUND HIM.

IF HE HEARS A SOUND OR SEES MOVEMENT HE WILL REACT WITH A ROAR AND BECOME ANIMATED.

OCCASIONALLY ROBORAPTOR™ WILL TURN HIS HEAD AND SNIFF.

AFTER 30 MINUTES ROBORAPTOR™ WILL POWER DOWN.

CAUTION: [ALTHOUGH ROBORAPTOR™ WILL NOT TAKE ANY STEPS WHILE HE IS IN GUARD MODE, DO NOT PUT HIM NEAR THE EDGE OF A TABLE SINCE HE COULD FALL OFF WHEN HE BECOMES ANIMATED.]

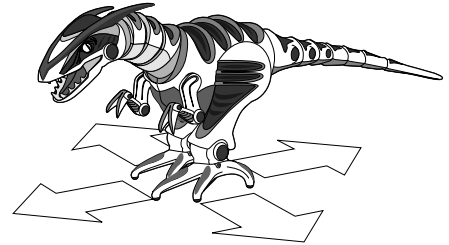



ADVANCED OPERATION

“LASER” TARGETING

ROBORAPTOR™ CAN BE GUIDED AROUND USING “LASER” TARGETING. POINT THE CONTROLLER AT THE FLOOR ONE FOOT IN FRONT OF THE ROBORAPTOR™ AND HOLD THE “LASER” TARGET TRIGGER .

THE GREEN TARGETING ASSIST LIGHT WILL SHINE SO YOU CAN SEE WHERE YOU ARE AIMING.

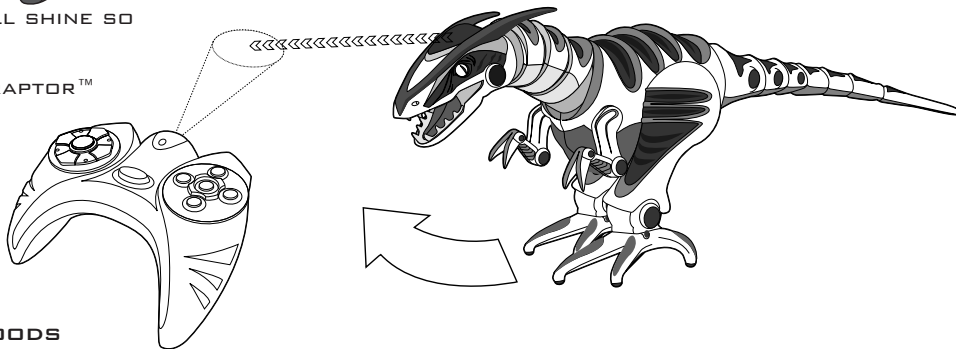

KEEP THE BUTTON PRESSED AND ROBORAPTOR™ WILL MOVE TOWARDS THE LIGHT.

ROBORAPTOR™ WILL SEE HIS “LASER” TARGETING BEAM MORE EASILY IF IT IS AIMED AT A VERTICAL SURFACE SUCH AS A WALL.



CONTROLLING ROBORAPTOR'S™ MOODS

ROBORAPTOR™ HAS THREE DIFFERENT MOODS, HUNTING, CAUTIOUS AND PLAYFUL. TO CHANGE ROBORAPTOR™'S MOODS USE THE “SHIFT” BUTTON .

- **HUNTING MOOD** : PRESS “SHIFT”  AND “HEAD CLOCKWISE / HUNTING MOOD”  TO PUT ROBORAPTOR™ INTO HUNTING MOOD. THIS MOOD IS THE DEFAULT MOOD THAT ROBORAPTOR™ IS IN WHEN TURNED ON.

- **PLAYFUL MOOD** : PRESS “SHIFT”  AND “TAIL RIGHT / PLAYFUL MOOD”  TO PUT ROBORAPTOR™ INTO PLAYFUL MOOD.

- **CAUTIOUS MOOD** : PRESS “SHIFT”  AND “TAIL LEFT / CAUTIOUS MOOD”  TO PUT ROBORAPTOR™ INTO CAUTIOUS MOOD.

THE MOODS DETERMINE THE WAY ROBORAPTOR™ REACTS TO SOME OF HIS SENSORS, (SEE “ROBORAPTOR™'S SENSORS” PAGE 7).



ADVANCED OPERATION

TOUCH SENSORS

ROBORAPTOR™ HAS MULTIPLE SENSORS WHICH ALLOW HIM TO EXPLORE HIS ENVIRONMENT AND RESPOND TO HUMAN INTERACTION.

TAIL TOUCH SENSORS: PRESS THE SENSORS ON ROBORAPTOR™'S TAIL TO SEE HIS REACTION. THE REACTION VARIES DEPENDING ON HIS MOOD.

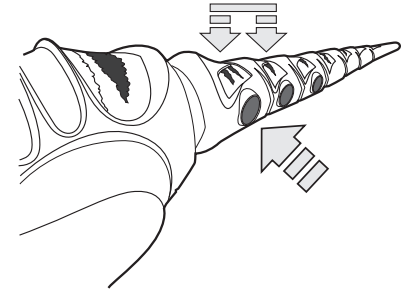

CHIN TOUCH SENSOR: PRESS THE SENSOR UNDER ROBORAPTOR™'S CHIN TO SEE HIS REACTION. THE REACTION VARIES DEPENDING ON HIS MOOD.

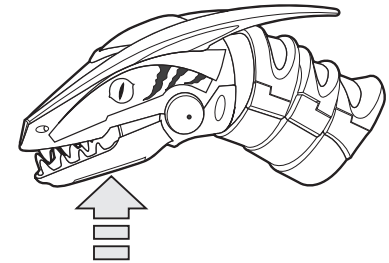

MOUTH TOUCH SENSOR: THERE IS A TOUCH SENSOR ON THE ROOF OF ROBORAPTOR™'S MOUTH. IN HUNTING MOOD, TOUCHING THIS SENSOR WILL TRIGGER A BITING AND TEARING ANIMATION. IN CAUTIOUS AND PLAYFUL MOODS, ROBORAPTOR WILL PLAY A TUG-OF-WAR WITH WHATEVER IS IN HIS MOUTH.

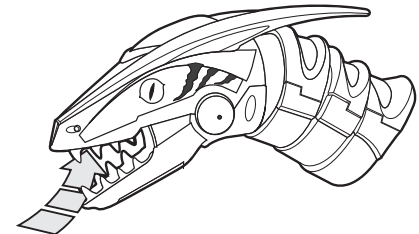



ADVANCED OPERATION

STEREO SOUND SENSORS:

ROBORAPTOR™ CAN DETECT SHARP, LOUD SOUNDS (LIKE A CLAP) TO HIS LEFT, HIS RIGHT AND DIRECTLY AHEAD. HE ONLY LISTENS WHEN HE IS NOT MOVING OR MAKING A NOISE.

HUNTING MOOD

WHEN HE HEARS A SHARP SOUND TO HIS SIDE HE WILL TURN HIS HEAD TO LOOK AT THE SOURCE.

IF HE HEARS ANOTHER SHARP SOUND FROM THE SAME DIRECTION HE WILL TURN HIS BODY TOWARDS THE SOURCE.

IF HE HEARS A SHARP SOUND DIRECTLY IN FRONT OF HIM HE WILL TAKE A FEW STEPS TOWARD THE SOURCE.

CAUTIOUS MOOD

WHEN HE HEARS A SHARP SOUND TO HIS SIDE HE WILL TURN HIS HEAD TO LOOK AT THE SOURCE.

IF HE HEARS A SOUND STRAIGHT AHEAD HE WILL WALK AWAY FROM IT.

PLAYFUL MOOD

WHEN HE HEARS A SHARP SOUND TO HIS SIDE HE WILL TURN HIS HEAD TO LOOK AT THE SOURCE.

IF HE HEARS A SOUND STRAIGHT AHEAD, HE WILL TAKE A FEW STEPS BACKWARD, THEN TAKE A FEW STEPS FORWARD.

INFRARED VISION SENSORS:

ROBORAPTOR™ HAS INFRARED VISION SENSORS THAT ENABLE HIM TO DETECT MOVEMENT TO EITHER SIDE OF HIM.

THE SENSORS REACT BEST TO MOVEMENT IN THE AREA JUST IN FRONT OF HIS NOSE AS SHOWN.

IN **PLAYFUL MOOD** ROBORAPTOR™ WILL NUZZLE YOUR HAND IF YOU APPROACH FROM THE SIDE.

IN **CAUTIOUS MOOD**, ROBORAPTOR™ WILL TURN HIS HEAD AWAY FROM MOVEMENT TO THE SIDE.

IN **HUNTING MOOD**, HIS REACTIONS ARE MUCH LESS FRIENDLY!

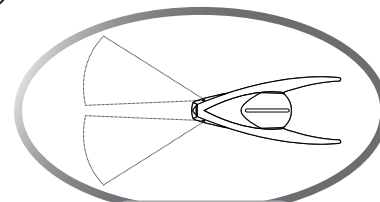
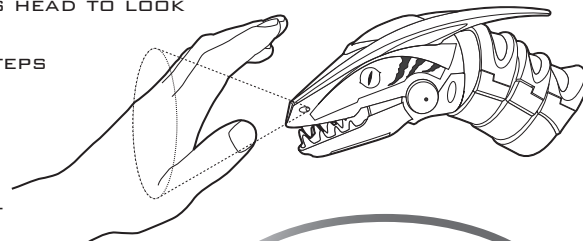
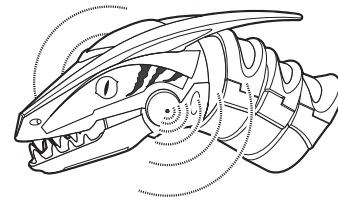

TOP VIEW



ADVANCED OPERATION

IF YOU TRIGGER THE VISION SENSOR ON ONE SIDE MORE THAN THREE TIMES IN A ROW, ROBORAPTOR™ WILL GET FRUSTRATED AND WILL TURN AWAY FROM YOU. THIS WILL ALSO HAPPEN IF YOU LEAVE HIM STANDING WITH HIS HEAD FACING A WALL.

OBSTACLE AVOIDANCE:

ROBORAPTOR™ USES HIS VISION SENSORS TO AVOID OBSTACLES WHILE WANDERING AROUND.

WHILE WALKING HE WILL NOT BE ABLE TO DETECT MOVEMENT SO HE WILL REACT TO YOU AS IF YOU ARE AN OBSTACLE.

PRESS THE “STOP” BUTTON BEFORE TRYING TO INTERACT WITH HIM.

ROBORAPTOR™’S INFRARED VISION SYSTEM AND THE “LASER” TARGETING ARE BASED ON REFLECTION. THIS MEANS THAT HE CAN SEE HIGHLY REFLECTIVE SURFACES LIKE WHITE WALLS OR MIRRORS MORE EASILY AND AT GREATER DISTANCES.

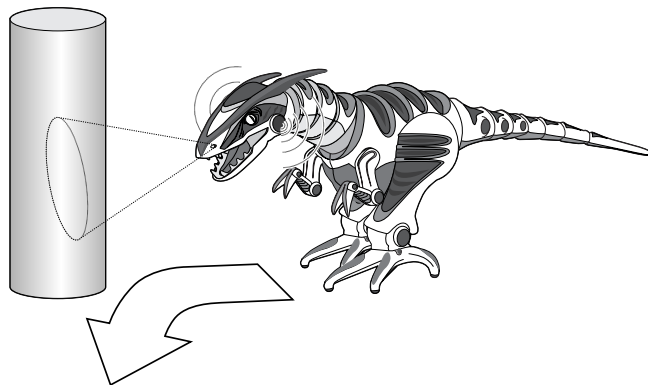

UNDERSTANDING YOUR ROBORAPTOR™

- ROBORAPTOR™ WALKS BEST ON SMOOTH SURFACES. USE THE TWO FASTER WALKING SPEEDS ON ROUGH SURFACES LIKE CARPETS.
- ROBORAPTOR™ RESPONDS TO REMOTE CONTROL COMMANDS MORE EASILY WHEN YOU ARE IN FRONT OF HIM. HE WILL NOT SEE AS WELL IF THE CONTROLLER IS BEHIND HIM.
- PLEASE NOTE: INFRARED FUNCTIONS CAN BE AFFECTED BY BRIGHT SUNLIGHT, FLUORESCENT AND ELECTRONICALLY DIMMED LIGHTING.
- UPON ACTIVATION ROBORAPTOR™ WILL BE SENSITIVE TO SOUND, VISION AND TOUCH.

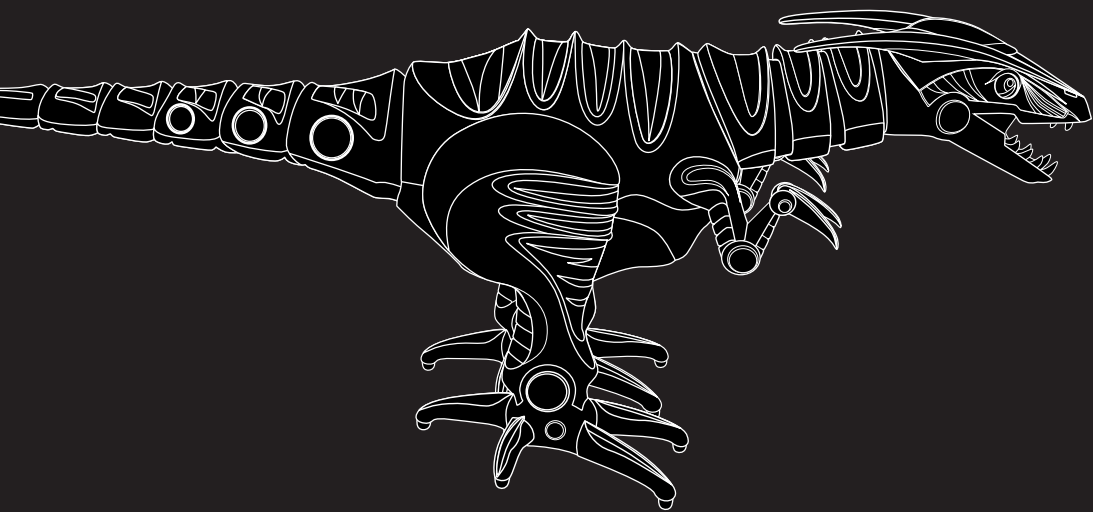

ws8095us02

We recommend that you retain our
address for future reference.
Product and colors may vary.
PRINTED IN CHINA.

Manufactured and distributed by
©2005 WowWee Ltd.
All Right Reserved.

WowWee (Asia Office)
Unit 301A-C, 92 Granville Rd.,
T.S.T. East, Hong Kong

WowWee (North American Office)
4480 Cote de Liesse, Suite 320,
T.M.R. Quebec, H4N 2R1, Canada
Consumer Hotline: 1-800-310-3033
www.wowwee.com