



Omnitrix

Companion





The Omnibot Companion

by The Old Robot . . .

<http://www.theoldrobots.com/>

Index

Part 1	1
Part 2	3
Part 3	6
Part 4	13
Part 5	25
Part 6	29
Part 7	35
Part 8	40
Part 9	43
Part 10	47
Part 11	53

The Omnibot® Companion Comparison is a collection of documentations and pictures and contains Omnibot® 5402 / TR5000, Omnibot® MK-II (Red) 5402 / TR5000, Omnibot® MK-II (White) 5402 / TR5000, Omnibot® Signal 5402 / TR5000, Omnibot® Pepsi 5402 / TR5000, Omnibot® Gold 5402 / TR5000, Omnibot® Silver 5402 / TR5000, Omnibot® Colgate 5402 / TR5000, Omnibot® (Blue) 5402 / TR5000, Omnibot® CD 5402 / TR5000 and Omnibot® XP 5402 / TR5000.

Detail information is available on the <http://www.theoldrobots.com/> web site.



Omnibot Companion

Welcome! If you have arrived at this book you have an interest in robots or robotics and you are looking for information. This book is the result of a researching, identifying, collecting and creating information and pictures for you.

Robot Companion is a fun, easy-to-understand, hands-on guide that will have you using your own robots in no time. The robot companion contains a diverse set of information and pictures of the robot to familiarizes a person with that robot.

This approach is used because so little information on the robots from the 1980s exists today and it will be helpful with the information instructions or manuals. They dance, tell jokes, and even clean your carpet! From the tiniest robot to gigantic machines, robotics is all around you.

This technology isn't just for science fiction anymore; it is real and more relevant than ever. With stunning visuals and energetic, impact designs, readers won't stop until they've learned everything to know about robots.

To the individuals that have designed and created these robots, and have put part of their lives in their work to successfully create these robots, the goal of this book is recognize these individuals and is dedicated to retain this information for history.

This book contains only part of the "First Wave of Robotics" and the research, time, frustrations, hope, knowledge and work that has gone into creating and building these robots pictures and information should be recognized.

The next generation of individuals and robots, will probably look different than addressed here. It is with this understanding that they will look different and present a different view.

The information and pictures of these robots is a recording of part of our history of robots and is intended to be part of that process. I hope that you copy and retain many or all of the pictures and information that is presented here and reuse them, as you need.

Robots are hear and now. In this day and age we tend to forget that robots are not a thing of the past, but are with us every day. As we paint or draw, look, sell, collect information, repair and use toy, educational, personal, industrial and commercial robots, I will still have people to ask me.

"What useful purpose do they serve? What can they do? Can they help me with my work? Are these just toys for children? Do they take my job away from me?"

My answer is: "They can do work and help us make a living and make our lives easier. It puts food on the table and a roof over our head. Robots help us do work, learn and entertain us, and is the proving grounds of our future advances in that technology, and it could be viewed as a experimental stage of our ideas."

I cannot say that robots of today are our products of tomorrow because they are our products of today. More than half of the world uses robots, or make there living from it. Engineering Design, Manufacturing, Delivery, Sales, Marketing, Management and Law are just a few of the areas affected.

Our Economy in this Century will be in very poor shape if it was not for robots.



Robot Companion is a fun, easy-to-understand, hands-on guide that will have you using your own robots in no time. The robots in this book include the "Omnibot Robot," the "Tomy Robots," and even a robot that carries a child on wheels!

You will learn how to find your robot, how to identify a robot by country through frequency allocation, where to buy parts, how to program your robot to perform tasks, and more. This book's companion website includes software program files, parts lists, and links to online parts suppliers.

The robot companion contains a diverse set of information and pictures of the robot to familiarize a person with that robot. This approach is used because so little information on the robots from the 1980's exists today, and it will be helpful with the information instructions or manual.

They dance, tell jokes, and even clean your carpet! From the tiniest robot to gigantic factory machines, robotics is all around you. This technology isn't just for science fiction anymore; it's real and more relevant than ever. With stunning visuals and energetic, impact design, readers won't stop until they've learned everything there is to know about robotics.

You'll be led step-by-step through the book. Along the way, you'll learn about robotic systems that use the same principles you're learning to use on your robot, and you'll get a glimpse into the future of robots.

Here is an example proposed:

I dream When I was created or born in the 1980's, I was one of the few and select robots that had a purpose, to play, teach and entertain. I was young, didn't have a onboard computer, but didn't need one at the time. Besides, they were not readily available and need by me for my purpose. Who say's a robot must always have a computer.

I could move around in all directions, learn, teach, sleep, wake up and move around to pre-programmed functions, tell time, talk from others, talk on my own after pre recording, had my own limited language, carry things, sing and entertain. I stimulated people to dream of new ideas for science and technology when they were young. Young minds looked at me and taught of ways to improve and give me more functions, grew up and invented them, but put them on others.

I dreamed of growing up and doing more things, I waited and waited. Even though I traveled around the world, was international in all areas, (all countries knew of me or sold me) my brothers and sisters did become famous through the movies, and I was regulated to my everyday tasks.

So I waited and dreamed of growing up and doing greater things. It has been over twenty-three years and to a robot that is like being over a (100) hundred years old. I have been put in attics, garages, and basements thrown away into the junkyards and forgotten.

But I am persistent, I still live and still I dream. I will survive; I am tough, versatile and have hopes and dreams of my purpose for a future. I wait and I dream Tomy ® Omnibot ®

Tomy has created toy robots throughout the years and in the 80's created a line of small personal robots. It is truly astounding what they were able to accomplish utilizing the resources at the time to manufacture and sell this product line.

The Omnibot had a cassette tape player built into the chest area of the robot, which slid out like a drawer to reveal the cassette and could record and playback sequences of commands, as well as regular audio recordings. The built in digital clock with timers and alarms allowed the playback of movement recordings at specified times. It could broadcast speech from the remote control handset through a speaker on the robot, and was shipped with a cardboard "home" base, which was suggested, to be taped to the floor and used as a reference point for programming. The Omnibot carried a specially made tray, which slotted into its claws, and could carry objects.



Omnibot © 5402 / TR5000



Omnibot © 5402 / TR5000 (Red)



Omnibot © 5402 / TR5000 (White)



Omnibot © 5402 / TR5000 (Silver)



Omnibot © 5402 / TR5000 (Almond Boy)



Omnibot © 5402 / TR5000 (Colgate)



Omnibot © 5402 / TR5000 (Pepsi)



Omnibot © 5402 / TR5000 (Red)



Omnibot © 5402 / TR5000 (Gold)



Omnibot © 5402 / TR5000 (Vintage)



Omnibot © 5402 / TR5000 (XP-Robot)



Omnibot © 5402 / TR5000 (XP-Robot)



Omnibot © 5402 / TR5000 (XP- Signal)



Omnibot © 5402 / TR5000 (Red)



Omnibot © 5402 / TR5000 (Blue)



Omnibot © 5402 / TR5000 (CD Robot)



Omnibot® 5402 Omnibot® 5402 Omnibot® 5402 Omnibot® 5402 Omnibot® 5402

Omnibot® 5402 / TR5000 By Tomy®



Omnibot MK- II® 5402 / TR - 5500 Omnibot MK- II® 5402 / TR - 5500 Omnibot MK- II® 5402 / TR - 5500 Omnibot MK- II® 5402 / TR - 5500

Omnibot MK- II® 5402 / TR - 5500 by Tomy®



Omnibot MK- II® 5402 / TR - 5500 Omnibot MK- II® 5402 / TR - 5500 Omnibot MK- II® 5402 / TR - 5500 Omnibot MK- II® 5402 / TR - 5500

Omnibot MK- II® 5402 / TR - 5500 by Tomy®



Omnibot® 5402 / TR - 5500 Omnibot® 5402 / TR - 5500 Omnibot® 5402 / TR - 5500 Omnibot® 5402 / TR - 5500

Omnibot® 5402 / TR - 5500 by Tomy®



Omnibot® 5402



Omnibot® 5402



Omnibot® 5402



Omnibot® 5402



Omnibot® 5402

Omnibot® 5402 / TR - 5500 by Tomy®



Omnibot® 5402



Omnibot® 5402



Omnibot® 5402



Omnibot® 5402



Omnibot® 5402

Omnibot® 5402 / TR - 5500 by Tomy®



Omnibot® 5402 / TR - 5500



Omnibot® 5402 / TR - 5500



Omnibot® 5402 / TR - 5500

Omnibot® 5402 / TR - 5500 by Tomy®

Omnibot	Omnibot MKII	Omnibot MKII White	Omnibot MKII Red	Gold Omnibot	Red Omnibot	Silver Omnibot	Specials	Omnibot XP	Compare
-------------------------	------------------------------	------------------------------------	----------------------------------	------------------------------	-----------------------------	--------------------------------	--------------------------	----------------------------	-------------------------

Omnibot 5402 XP® By Tomy® Other Examples Links



Omnibot 5402/TR5000 by Tomy
[Click to Enlarge](#)



Omnibot 5402/TR5000
[Click to Enlarge](#)



Omnibot 5402/TR5000
[Click to Enlarge](#)



Omnibot 5402/TR5000
[Click to Enlarge](#)



Omnibot 5402/TR5000
[Click to Enlarge](#)



Omnibot 5402 - Tomy has created toy robots throughout the years and in the 80's created a line of small personal robots. It is truly astounding what they were able to accomplish utilizing the resources at the time to manufacture and sell this product line.

The Omnibot had a cassette tape player built into the chest area of the robot, which slid out like a drawer to reveal the cassette and could record and playback sequences of commands, as well as regular audio recordings. The built in digital clock with timers and alarms allowed the playback of movement recordings at specified times. It was able to broadcast speech from the remote control handset through a speaker on the robot, and was shipped with a cardboard "home" base which was suggested to be taped to the floor and used as a reference point for programming. The Omnibot carried a specially made tray which slotted into its claws, and could carry objects.

Robot Specifications:

1. Tape Cassette Recorder Type: 2 track monaural , Tape Selection: normal bias only , Tape Speed: +/- 3% , Wow & Flutter: within 0.3%

- 2. Alarm Clock display: LCD accuracy: +/- 2 sec/day power: 1.5v AA battery duration: typical 5000 hours
- 3. Recharger (U.L. listed) coax plug (negative middle) in: 120 VAC - out: 6 VDC, 400 ma
- 4. Main Battery Type: sealed lead acid , Output Rating: 6 V, 4.0 Ah , Physical Size: 2 1/4"L x 1 3/4"W x 4"H , Terminals / Connectors: lead wires with coaxial 'barrel-type' connector (negative center pole)
- 5. General Operating time: Battery Life: 4 hours continuous at 5.5 V (normal) , Battery Indicator: red light indicates when discharged to 5.77 volts , Operating Temperatures: 41 Degrees F~104 Degrees F (5 Degrees C~40 Degrees C)
- 6. Microphone type: dynamic, 300 - 600
- 7. Operating R/C frequency: The Remote came in 3 Frequencies: 49.860 Mhz (US), 27.145 Mhz (Europe), 40.680 Mhz (TAL)
- 8. External outlets: Speaker: 8 ohms
- 9. Bulbs for eye-lights 2.8v, 200ma use not more than 3v 250ma
- 10. Remote Control 4 * 1.5v (AA)

Accessories : Controller, Detachable tray 2.2 lbs maximum weight allowance, Demonstration cassette tape, Battery charger, Home Base, Tuner



Omnibot MK-II[®] TR5500 (Red) by Tomy[®]



Omnibot MK-II[®] TR5503 (White) by Tomy[®]

Omnibot MK II 5402 - Tomy has created toy robots throughout the years and in the 80's created a line of small personal robots. It is truly astounding what they, and other companies, were able to accomplish utilizing the resources at the time to manufacture and sell this product line.

The Omnibot MK II had a cassette tape player built into the chest area of the robot, which slid out like a drawer to reveal the cassette and could record and playback sequences of commands, as well as regular audio recordings. The built in digital clock with timers and alarms allowed the playback of movement recordings at specified times. It was able to broadcast speech from the remote control handset through a speaker on the robot, and was shipped with a cardboard "home" base which was suggested to be taped to the floor and used as a reference point for programming. The Omnibot carried a specially made tray which slotted into its claws, and could carry objects.

Many hobbyists have turned to hacking, tweaking and improving their Omnibots. Commonly added features are IR Sensors, video cameras, speech recognition chips, stronger motors, microcontrollers, sonars and other advanced enhancements that would not have been possible in the 80s.

Robot Specifications:

1. Tape Cassette Recorder Type: 2 track monaural , Tape Selection: normal bias only , Tape Speed: +/- 3% , Wow & Flutter: within 0.3%
2. Alarm Clock display: LCD accuracy: +/- 2 sec/day power: 1.5v AA battery duration: typical 5000 hours
3. Recharger (U.L. listed) coax plug (negative middle) in: 120 VAC - out: 6 VDC, 400 ma
4. Main Battery Type: sealed lead acid , Output Rating: 6 V, 4.0 Ah , Physical Size: 2 1/4"L x 1 3/4"W x 4"H, Terminals / Connectors: lead wires with coaxial 'barrel-type' connector (negative center pole)
5. General Operating time: Battery Life: 4 hours continuous at 5.5 V (normal) , Battery Indicator: red light indicates when discharged to 5.77 volts , Operating Temperatures: 41 Degrees F~104 Degrees F (5 Degrees C~40 Degrees C)
6. Microphone type: dynamic, 300 - 600
7. Operating R/C frequency: The Remote came in 3 Frequencies: 49.860 Mhz (US), 27.145 Mhz (Europe), 40.680 Mhz (TAL)
8. External outlets: Speaker: 8 ohms
9. Bulbs for eye-lights 2.8v, 200ma use not more than 3v 250ma 10. Remote Control 4 * 1.5v (AA)

Accessories

- Controller
- Detachable tray 2.2 lbs maximum weight allowance
- Demonstration cassette tape
- Battery charger
- Home Base
- Tuner



Omnibot MK II - TR5500



Omnibot MK II - TR5500



Omnibot MK II - TR5500



Omnibot MK II - TR5500



Omnibot MK II - TR5500



MY Thanks to omnibotfreak38 "A Omnibot/Fish Collector" for the Red Omnibot MK II Movie.



Omnibot/MK II

I dream. When I was created or born in the 1980's, I was one of the few and select robots that had a purpose, to play, teach and entertain. I was young, didn't have an onboard computer, but didn't need one at the time. Besides, they were not readily available and need by me for my purpose. Who says a robot must always have a computer.

I could move around in all directions, learn, teach, sleep, wake up and move around to pre-programmed functions, tell time, talk from others, talk on my own after pre recording, had my own limited language, carry things, sing and entertain. I stimulated people to dream of new ideas for science and technology when they were young. Young minds looked at me and thought of ways to improve and give me more functions, grew up and invented them, but put them on others.

I dreamed of growing up and doing more things, I waited and waited. Even though I traveled around the world, was international in all areas, (all countries knew of me or sold me) my brothers and sisters did become famous through the movies, and I was regulated to my everyday tasks.

So I waited and dreamed of growing up and doing greater things. It has been over twenty-three years and to a robot that is like being over a (100) hundred years old. I have been put in attics, garages, and basements thrown away into the junkyards and forgotten.

But I am persistent, I still live and still I dream. I will survive; I am tough, versatile and have hopes and dreams of my purpose for a future. I wait and I dream

Omnibot® 5402



Omnibot MK II - TR5503



Omnibot MK II - TR5503



Omnibot MK II - TR5503



Omnibot MK II - TR5503



Omnibot MK II - TR5503



MY Thanks to the omnibotfreak38 "A Omnibot/Fish Collector" for the White Omnibot MK II Movie.



Omnibot MK II

I dream. When I was created or born in the 1980's, I was one of the few and select robots that had a purpose, to play, teach and entertain. I was young, didn't have a onboard computer, but didn't need one at the time. Besides, they were not readily available and need by me for my purpose. Who say's a robot must always have a computer.

I could move around in all directions, learn, teach, sleep, wake up and move around to pre-programmed functions, tell time, talk from others, talk on my own after pre recording, had my own limited language, carry things, sing and entertain. I stimulated people to dream of new ideas for science and technology when they were young. Young minds looked at me and taught of ways to improve and give me more functions, grew up and invented them, but put them on others.

I dreamed of growing up and doing more things, I waited and waited. Even though I traveled around the world, was international in all areas, (all countries knew of me or sold me) my brothers and sisters did become famous through the movies, and I was regulated to my everyday tasks.

So I waited and dreamed of growing up and doing greater things. It has been over twenty-three years and to a robot that is like being over a (100) hundred years old. I have been put in attics, garages, and basements thrown away into the junkyards and forgotten.

But I am persistent, I still live and still I dream. I will survive; I am tough, versatile and have hopes and dreams of my purpose for a future. I wait and I dream

Omnibot® 5402



Omnibot 5402 X - Front



Omnibot 5402 X - Front



Omnibot 5402 X - Back



Omnibot 5402 X - Side



Omnibot 5402 X - Side



Gold Omnibot 5402[®] by Tomy[®]

Tomy has created toy robots throughout the years and in the 80's created a line of small personal robots. It is truly astounding what they, and other companies, were able to accomplish utilizing the resources at the time to manufacture and sell this product line.

The Omnibot had a cassette tape player built into the chest area of the robot, which slid out like a drawer to reveal the cassette and could record and playback sequences of commands, as well as regular audio recordings.

The built in digital clock with timers and alarms allowed the playback of movement recordings at specified times.

It was able to broadcast speech from the remote control handset through a speaker on the robot, and was shipped with a cardboard "home" base which was suggested to be taped to the floor and used as a reference point for programming. The Omnibot carried a specially made tray which slotted into its claws, and could carry objects.

Robot Specifications:

1. Tape Cassette Recorder Type: 2 track monaural , Tape Selection: normal bias only , Tape Speed: +/- 3% , Wow & Flutter: within 0.3%
2. Alarm Clock display: LCD accuracy: +/- 2 sec/day power: 1.5v AA battery duration: typical 5000 hours
3. Recharger (U.L. listed) coax plug (negative middle) in: 120 VAC - out: 6 VDC, 400 ma
4. Main Battery Type: sealed lead acid , Output Rating: 6 V, 4.0 Ah, Physical Size: 2 1/4"L x 1 3/4"W x 4"H , Terminals / Connectors: lead wires with coaxial 'barrel-type' connector (negative center pole)
5. General Operating time: Battery Life: 4 hours continuous at 5.5 V (normal) , Battery Indicator: red light indicates when discharged to 5.77 volts , Operating Temperatures: 41 Degrees F~104 Degrees F (5 Degrees C~40 Degrees C)
6. Microphone type: dynamic, 300 - 600
7. Operating R/C frequency: The Remote came in 3 Frequencies: 49.860 Mhz (US), 27.145 Mhz (Europe), 40.680 Mhz (TAL)
8. External outlets: Speaker: 8 ohms
9. Bulbs for eye-lights 2.8v, 200ma use not more than 3v 250ma 10. Remote Control 4 * 1.5v (AA)

Accessories

- Controller
- Detachable tray 2.2 lbs maximum weight allowance
- Demonstration cassette tape
- Battery charger
- Home Base
- Tuner



Red Robot[®] - Front



Red Robot[®] - Angle



Red Robot[®] - Back



Red Robot[®] - Right Side



Red Robot[®] - Left Side

Red Omnibot 5402[®] - Tomy has created toy robots throughout the years and in the 80's created a line of small personal robots. It is truly astounding what they, and other companies, were able to accomplish utilizing the resources at the time to manufacture and sell this product line.

The Omnibot had a cassette tape player built into the chest area of the robot, which slid out like a drawer to reveal the cassette and could record and playback sequences of commands, as well as regular audio recordings. The built in digital clock with timers and alarms allowed the playback of movement recordings at specified times. It was able to broadcast speech from the remote control handset through a speaker on the robot, and was shipped with a cardboard "home" base which was suggested to be taped to the floor and used as a reference point for programming. The Omnibot carried a specially made tray which slotted into its claws, and could carry objects.

Robot Specifications:

1. Tape Cassette Recorder Type: 2 track monaural , Tape Selection: normal bias only , Tape Speed: +/- 3% , Wow & Flutter: within 0.3%
2. Alarm Clock display: LCD accuracy: +/- 2 sec/day power: 1.5v AA battery duration: typical 5000 hours
3. Recharger (U.L. listed) coax plug (negative middle) in: 120 VAC - out: 6 VDC, 400 ma
4. Main Battery Type: sealed lead acid , Output Rating: 6 V, 4.0 Ah , Physical Size: 2 1/4"L x 1 3/4"W x 4"H , Terminals / Connectors: lead wires with coaxial 'barrel-type' connector (negative center pole)
5. General Operating time: Battery Life: 4 hours continuous at 5.5 V (normal) , Battery Indicator: red light indicates when discharged to 5.77 volts , Operating Temperatures: 41 Degrees F~104 Degrees F (5 Degrees C~40 Degrees C)
6. Microphone type: dynamic, 300 - 600
7. Operating R/C frequency: The Remote came in 3 Frequencies: 49.860 Mhz (US), 27.145 Mhz (Europe), 40.680 Mhz (TAL)
8. External outlets: Speaker: 8 ohms
9. Bulbs for eye-lights 2.8v, 200ma use not more than 3v 250ma 10. Remote Control 4 * 1.5v (AA)

Accessories

- Controller
- Detachable tray 2.2 lbs maximum weight allowance
- Demonstration cassette tape
- Battery charger
- Home Base
- Tuner



Omnibot 5402 Silver Robot



Omnibot 5402 Silver Robot



Omnibot 5402 Silver Robot



Omnibot 5402 Silver Robot



Omnibot 5402 Silver Robot

Silver Omnibot 5402® - Tomy has created toy robots throughout the years and in the 80's created a line of small personal robots. It is truly astounding what they, and other companies, were able to accomplish utilizing the resources at the time to manufacture and sell this product line.

The Omnibot had a cassette tape player built into the chest area of the robot, which slid out like a drawer to reveal the cassette and could record and playback sequences of commands, as well as regular audio recordings. The built in digital clock with timers and alarms allowed the playback of movement recordings at specified times. It was able to broadcast speech from the remote control handset through a speaker on the robot, and was shipped with a cardboard "home" base which was suggested to be taped to the floor and used as a reference point for programming. The Omnibot carried a specially made tray which slotted into its claws, and could carry objects.

Robot Specifications:

1. Tape Cassette Recorder Type: 2 track monaural, Tape Selection: normal bias only, Tape Speed: +/- 3%, Wow & Flutter: within 0.3%
2. Alarm Clock display: LCD accuracy: +/- 2 sec/day power: 1.5v AA battery duration: typical 5000 hours
3. Recharger (U.L. listed) coax plug (negative middle) in: 120 VAC - out: 6 VDC, 400 ma
4. Main Battery Type: sealed lead acid, Output Rating: 6 V, 4.0 Ah, Physical Size: 2 1/4"L x 1 3/4"W x 4"H, Terminals / Connectors: lead wires with coaxial 'barrel-type' connector (negative center pole)
5. General Operating time: Battery Life: 4 hours continuous at 5.5 V (normal), Battery Indicator: red light indicates when discharged to 5.77 volts, Operating Temperatures: 41 Degrees F~104 Degrees F (5 Degrees C~40 Degrees C)
6. Microphone type: dynamic, 300 - 600
7. Operating R/C frequency: The Remote came in 3 Frequencies: 49.860 Mhz (US), 27.145 Mhz (Europe), 40.680 Mhz (TAL)
8. External outlets: Speaker: 8 ohms
9. Bulbs for eye-lights 2.8v, 200ma use not more than 3v 250ma 10. Remote Control 4 * 1.5v (AA)

Accessories

Controller ; Detachable tray 2.2 lbs maximum weight allowance ; Demonstration cassette tape
 Battery charger ; Home Base ; Tuner



Omnibot 5402 (TOMY)



Omnibot 5402 (No Name)



Omnibot MK II - 5402 (TOMY)



Robie Sr (Radio Shack)



Hearoid & OOM (TOMY)



Hearoid & OOM (TTC)



Hearoid (TTC)



Omnibot 2000 (TOMY)



Original Omnitbot - 2.76 X 1.85 X 4.15
Omnibot 5402 - 6v 4.0 ah
Sealed Lead Acid Battery



Original Omnitbot - 2.76 X 1.85 X 4.15
yuasa np-4-6w 6v 4.0 ah
Sealed Lead Acid Battery



Replacement: B.B. Battery BP5-6
Sealed Lead Acid Battery
2.76" x 1.85" x 4.10"



Replacement: CSB
GP 645 6V 4.5Ah
Sealed Lead Acid Battery



Replacement: WERKER WK46-5F
6V 5Ah AGM
Sealed Lead Acid Battery



Omnibot 2000
input 240 V 50 Mh
6VDC 400ma



Omnibot
Tomy 2EX-5441
6VDC 300ma



Hearoid / OOM
TAMRADIO
25A-3532 400ma



Omnibot MK II
TAMRADIO
29A-4135 400ma



Robie Sr.
TC-604U
6VDC 600ma



Omnibot Replacement:
Radio Shack Battery Charger
60-2395 6VDC 600ma

* Battery Chargers will range from 300ma to 600ma for lead acid batteries. See battery specifications and their recommendations.



Omnibot 5402 - Later Version



Omnibot 5402 - Early Version



Omnibot MK II - 5402



Robie Sr



Hearoid & OOM



Omnibot 2000



Omnibot MK II 5402



Omnibot MK II 5402

* All wheels are interchangeable except for the Omnibot 2000



Robie Sr

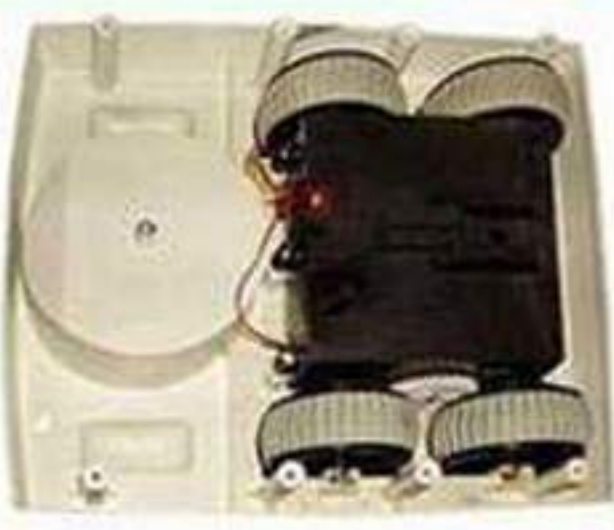

Omnibot 5402



Omnibot OOM / Hearoid



Omnibot 2000

* All gearboxes are interchangeable except for the Omnibot 2000

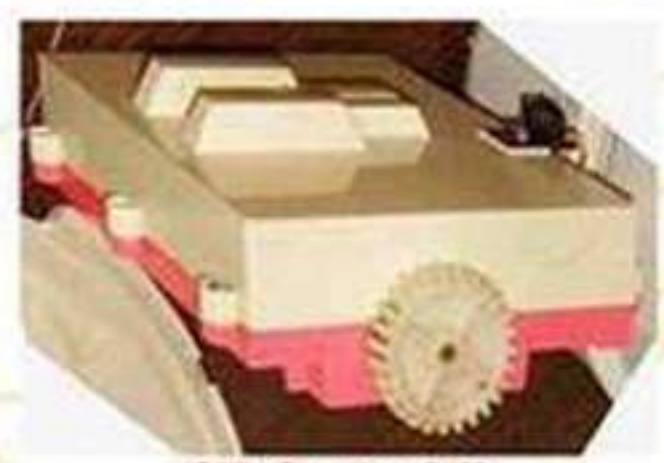

(Old) Omnibot 5402



Omnibot 5402



OOM / Hearoid



Robie Sr

* All gearboxes are interchangeable except for the Omnibot 2000



Omnibot 2000

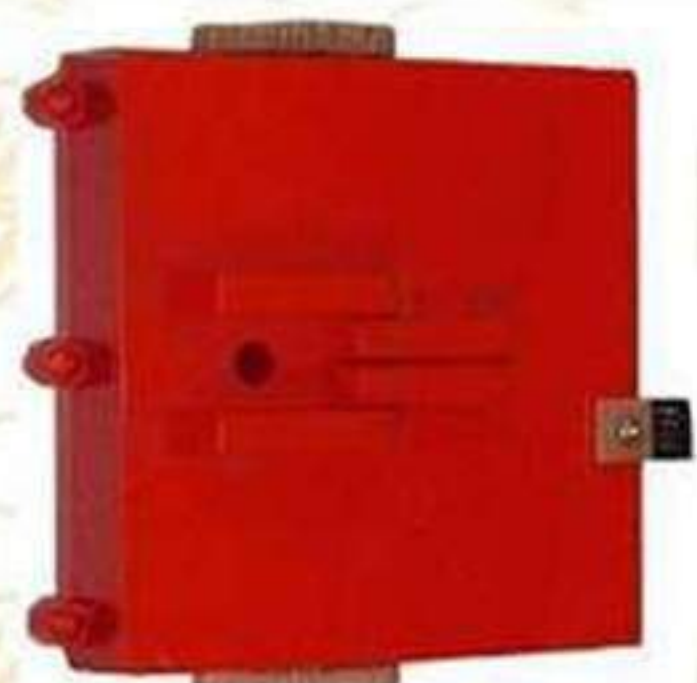

Omnibot 2000

* All gearboxes are interchangeable except for the Omnibot 2000



Omnibot 5402 - English



Omnibot 5402 - English



Omnibot 5402 - English



Omnibot 5402 - English



Omnibot 5402 - English



Omnibot 5402 - English/French



Omnibot 5402 - English/French



Omnibot 5402 - Japan



Omnibot 5402 - Japan



Omnibot 5402 - Japan



Omnibot 5402 - Japan



Omnibot 5402 - Japan



Omnibot 5402 - English



Omnibot 5402 - Asia



Omnibot 5402 - Insert # 1



Omnibot 5402 - Insert # 2



Omnibot 5402 - English



Omnibot 5402 - Asia



Omnibot 5402 - English French - Canada



Omnibot 5402 TR5000



Omnibot MK II - Box



Omnibot MK II - Box



Omnibot MK II - Box



Omnibot MK II - Box

* This is Omnibot Robot Family of Boxes.



Omnibot Microphone TR 5030



Omnibot Microphone TR 5030



Omnibot Microphone TR 5030

* This is comparison for Omnibot 5402



Robie Sr. by Radio Shack Tray



Omnibot 5402 By Tomy Tray



Omnibot MK II - Tray



Robie Sr. by Radio Shack Cassette Tape & Tuner



Omnibot 5402 Cassette Tape & Tuner



Omnibot MK II Cassette Tape & Tuner



Omnibot 5402 Button
Click to Enlarge

* This is comparison for Omnibot 5402



Hearoid, Omnibot 2000, MK II



Omnibot 5402, Robie Sr



Hearoid / OOM



All Other Omnibots

* This is comparison for Omnibot 5402

Tomy[®] has created many toy robots throughout the years and in the 80's created a line of small Personal robots. The Omnibot programming is done by recording the movement commands to a regular cassette tape which can be played back at certain times by using the built-in clock. The specs below are for the Omnibot.

1. Tape recorder two tracks, mono tape type: normal tape speed: +/- 0.3% deviation: less then 0.3
2. Alarm clock display: LCD accuracy: +/- 3 sec/day power: 1.5v AA battery duration: typical 5000 hours
3. Recharger coax plug (negative middle) in: 120vac out: 6vdc, 300 ma
4. Main Battery type: closed, lead gel cell power: 6v, 4.0ah
5. General Operating time: 4 hours Load display: Red light, shows discharge at 5.7v operating temp: 5 deg - 40 deg celsius
6. Microphone type: dynamic, 300 - 600 ohms
7. Operating R/C frequency: The Remote came in 3 Frequencies: 49.860 Mhz (US), 27.145 Mhz (Europe), 40.680 Mhz (TAL)
8. Bulbs for eye lights 2.8v, 200 ma use not more than 3v 250 ma 10. Remote Control 4 * 1.5v (AA)

Remote Features Omnibot[®] 5402: The Master Control Unit (MCU) has an antenna with its power switch & indicator. It has a button to push in to talk through its microphone to the robot in which the robot will respond with eyes flickering. It has all the buttons to control the robot as follows: Left side buttons for tape start/stop, omnibot sounds, Microphone on/off key. Right side of remote controls movement of robot to go forward/reverse, left/right turn and stop.

The Omnibot[®] series robots was manufactured by Tomy[®], TTC[®] and Radio Shack[®] in the 1980s. The name then came to apply to the successful line of robots manufactured by the Tomy company. The initial Omnibot was announced with expectations of restoring popular interest in robots and with the success of the Omnibots, the Omnibot range quickly expanded. The original Omnibot became the cover photo for the 1980s book, "The World of Robots" and recently the Omnibot 2000 graced the cover of "Toy Robots from Japan" by Alan Bunkum.

The Omnibot[®], MK II, Hearoid[®], OOM[®], Robie[®] Sr and the Omnibot[®] 2000 had a cassette tape player built into the chest area of the robot, which slid out like a drawer to reveal the cassette and could record and playback sequences of commands, as well as regular audio recordings. The built in digital clock with timers and alarms allowed the playback of movement recordings at specified times. All the robots were able to broadcast speech from the remote control handset through a speaker on the robot. The Omnibot and Robie Sr were similar in operation while the Hearoid, OOM, MK II and the Omnibot 2000 had other functions that specialized them. All could carry objects in one way or another.



OMNIBOT ACCESSORIES GROUP



Robo Link
Click to Enlarge



Robo Link
Click to Enlarge



Robo Link
Click to Enlarge

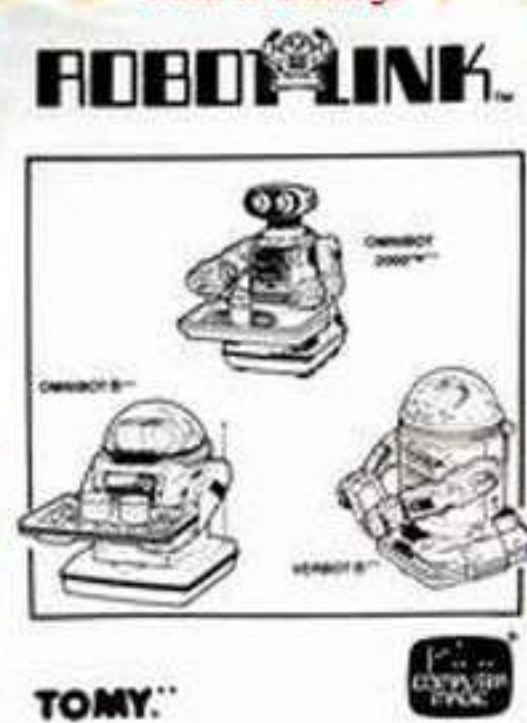

Robo Link



Robo Link



Robo Link



Robo Link

Robo Link
Robo Link for Omnibot 2000, Omnibot, and Hearoid!

Robo Link™ by Computer Magic for Omnibot 2000, Omnibot, and Hearoid! Robot Link is a computer software tool which enables you to program the Tomy robots from your home computer. It lets you program your robot on your computer saving you time and batteries. Create stories, games, tasks, dances . . . anything your imagination can think of with your Robot Link. Years of enjoyment, as well as a truly fun educational experience await you.

1	2	3	4	5	6	7	8	9	10	11	12	13	14	15	16	17	18	19	20	21	22	23	24	25	26	27	28	AA
---	---	---	---	---	---	---	---	---	----	----	----	----	----	----	----	----	----	----	----	----	----	----	----	----	----	----	----	----

	TABLE OF CONTENTS	1. INTRODUCTION	2. INSTALLATION	3. USING ROBO LINK	4. USING ROBO LINK TO PROGRAM	5. USING ROBO LINK TO RUN	6. USING ROBO LINK TO SAVE	7. USING ROBO LINK TO DELETE	8. USING ROBO LINK TO PRINT	9. USING ROBO LINK TO COPY	10. USING ROBO LINK TO PASTE	11. USING ROBO LINK TO MOVE	12. USING ROBO LINK TO RENAME	13. USING ROBO LINK TO DELETE	14. USING ROBO LINK TO COPY	15. USING ROBO LINK TO PASTE	16. USING ROBO LINK TO MOVE	17. USING ROBO LINK TO RENAME	18. USING ROBO LINK TO DELETE	19. USING ROBO LINK TO COPY	20. USING ROBO LINK TO PASTE	21. USING ROBO LINK TO MOVE	22. USING ROBO LINK TO RENAME	23. USING ROBO LINK TO DELETE	24. USING ROBO LINK TO COPY	25. USING ROBO LINK TO PASTE	26. USING ROBO LINK TO MOVE	27. USING ROBO LINK TO RENAME	28. USING ROBO LINK TO DELETE	29. USING ROBO LINK TO COPY	30. USING ROBO LINK TO PASTE	31. USING ROBO LINK TO MOVE	32. USING ROBO LINK TO RENAME	33. USING ROBO LINK TO DELETE	34. USING ROBO LINK TO COPY	35. USING ROBO LINK TO PASTE	36. USING ROBO LINK TO MOVE	37. USING ROBO LINK TO RENAME	38. USING ROBO LINK TO DELETE	39. USING ROBO LINK TO COPY	40. USING ROBO LINK TO PASTE	41. USING ROBO LINK TO MOVE	42. USING ROBO LINK TO RENAME	43. USING ROBO LINK TO DELETE	44. USING ROBO LINK TO COPY	45. USING ROBO LINK TO PASTE	46. USING ROBO LINK TO MOVE	47. USING ROBO LINK TO RENAME	48. USING ROBO LINK TO DELETE	49. USING ROBO LINK TO COPY	50. USING ROBO LINK TO PASTE	51. USING ROBO LINK TO MOVE	52. USING ROBO LINK TO RENAME	53. USING ROBO LINK TO DELETE	54. USING ROBO LINK TO COPY	55. USING ROBO LINK TO PASTE	56. USING ROBO LINK TO MOVE	57. USING ROBO LINK TO RENAME	58. USING ROBO LINK TO DELETE	59. USING ROBO LINK TO COPY	60. USING ROBO LINK TO PASTE	61. USING ROBO LINK TO MOVE	62. USING ROBO LINK TO RENAME	63. USING ROBO LINK TO DELETE	64. USING ROBO LINK TO COPY	65. USING ROBO LINK TO PASTE	66. USING ROBO LINK TO MOVE	67. USING ROBO LINK TO RENAME	68. USING ROBO LINK TO DELETE	69. USING ROBO LINK TO COPY	70. USING ROBO LINK TO PASTE	71. USING ROBO LINK TO MOVE	72. USING ROBO LINK TO RENAME	73. USING ROBO LINK TO DELETE	74. USING ROBO LINK TO COPY	75. USING ROBO LINK TO PASTE	76. USING ROBO LINK TO MOVE	77. USING ROBO LINK TO RENAME	78. USING ROBO LINK TO DELETE	79. USING ROBO LINK TO COPY	80. USING ROBO LINK TO PASTE	81. USING ROBO LINK TO MOVE	82. USING ROBO LINK TO RENAME	83. USING ROBO LINK TO DELETE	84. USING ROBO LINK TO COPY	85. USING ROBO LINK TO PASTE	86. USING ROBO LINK TO MOVE	87. USING ROBO LINK TO RENAME	88. USING ROBO LINK TO DELETE	89. USING ROBO LINK TO COPY	90. USING ROBO LINK TO PASTE	91. USING ROBO LINK TO MOVE	92. USING ROBO LINK TO RENAME	93. USING ROBO LINK TO DELETE	94. USING ROBO LINK TO COPY	95. USING ROBO LINK TO PASTE	96. USING ROBO LINK TO MOVE	97. USING ROBO LINK TO RENAME	98. USING ROBO LINK TO DELETE	99. USING ROBO LINK TO COPY	100. USING ROBO LINK TO PASTE
--	--------------------------	------------------------	------------------------	---------------------------	--------------------------------------	----------------------------------	-----------------------------------	-------------------------------------	------------------------------------	-----------------------------------	-------------------------------------	------------------------------------	--------------------------------------	--------------------------------------	------------------------------------	-------------------------------------	------------------------------------	--------------------------------------	--------------------------------------	------------------------------------	-------------------------------------	------------------------------------	--------------------------------------	--------------------------------------	------------------------------------	-------------------------------------	------------------------------------	--------------------------------------	--------------------------------------	------------------------------------	-------------------------------------	------------------------------------	--------------------------------------	--------------------------------------	------------------------------------	-------------------------------------	------------------------------------	--------------------------------------	--------------------------------------	------------------------------------	-------------------------------------	------------------------------------	--------------------------------------	--------------------------------------	------------------------------------	-------------------------------------	------------------------------------	--------------------------------------	--------------------------------------	------------------------------------	-------------------------------------	------------------------------------	--------------------------------------	--------------------------------------	------------------------------------	-------------------------------------	------------------------------------	--------------------------------------	--------------------------------------	------------------------------------	-------------------------------------	------------------------------------	--------------------------------------	--------------------------------------	------------------------------------	-------------------------------------	------------------------------------	--------------------------------------	--------------------------------------	------------------------------------	-------------------------------------	------------------------------------	--------------------------------------	--------------------------------------	------------------------------------	-------------------------------------	------------------------------------	--------------------------------------	--------------------------------------	------------------------------------	-------------------------------------	------------------------------------	--------------------------------------	--------------------------------------	------------------------------------	-------------------------------------	------------------------------------	--------------------------------------	--------------------------------------	------------------------------------	-------------------------------------	------------------------------------	--------------------------------------	--------------------------------------	------------------------------------	-------------------------------------	------------------------------------	--------------------------------------	--------------------------------------	------------------------------------	--------------------------------------

Robo Link Manual # - Original



INFRARED SENSOR - No. 5412



INFRARED SENSOR - No. 5412



INFRARED SENSOR - No. 5412



INFRARED SENSOR - No. 5412

INFRARED SENSOR - No. 5412

Ideas for your new INFRARED SENSOR accessory: Your robot can show off at yard sales, advertise specials, and carry goods on his tray: Stuck in a dark corner? Don't panic. Let your robot buddy lead the way as he steers you out of the darkness with his INFRARED SENSOR!



TRACER TAPE - No. 5413



TRACER TAPE - No. 5413



TRACER TAPE - No. 5413



TRACER TAPE - No. 5413

TRACER TAPE - No. 5413

Ideas for your new TRACER TAPE accessory: Your robot can deliver memos and secret messages and personal notes. Just plot a course to deliver routine correspondence with a tape.



PHOTO SENSOR - No. 5414



PHOTO SENSOR - No. 5414



PHOTO SENSOR - No. 5414



PHOTO SENSOR - No. 5414

PHOTO SENSOR - No. 5414

Ideas for your new PHOTO SENSOR accessory: Even in the dark, your Securitroid will be ready to catch a thief! Have your robot come to life just by flipping off or on a light. Your mechanical pal makes a great alarm when the sun rises!



ULTRASONIC SENSOR - No. 5415



ULTRASONIC SENSOR - No. 5415



ULTRASONIC SENSOR - No. 5415

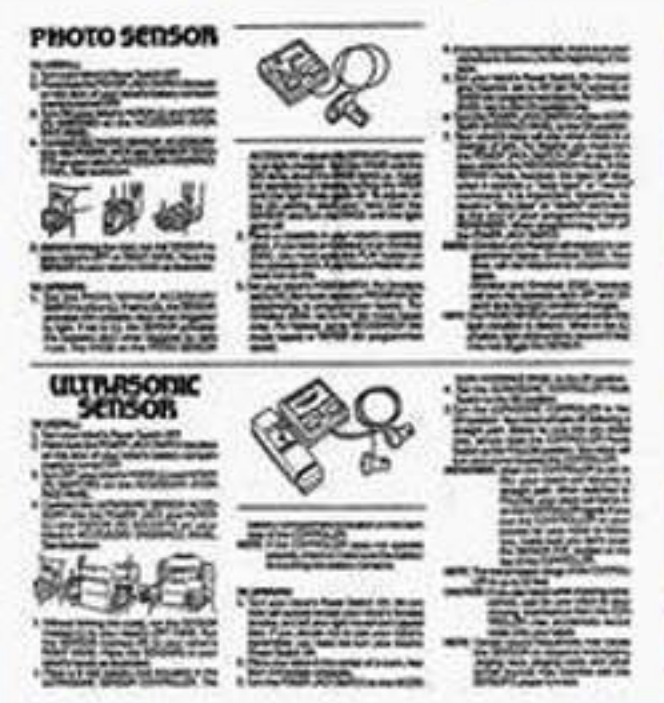

ULTRASONIC SENSOR - No. 5415

ULTRASONIC SENSOR - No. 5415

Ideas for your new ULTRASONIC SENSOR accessory:

Amaze your friends! Hold the transmitter out of sight and your mechanical man will follow you everywhere... like magic!

Your robot can show-off at yard sales, advertises specials, and carry goods on his tray.

Let your robot race with your baby brother or sister! See who's the fastest.



SECURITY DETECTOR - No.



SECURITY DETECTOR - No.



SECURITY DETECTOR - No.



SECURITY DETECTOR - No.

SECURITY DETECTOR - No.

Even in the dark, your Securitroid will be ready to catch a thief!



Tomy Personal Robots



Omnibot MK-II



Omnibot 2000 - 5405



Tomy Omnibot Family



Tomy Omnibot Family



Omnibot Ad's



Omnibot 5402



Colgate Omnitobot 5402



Omnibot MK II



Omnibot 5402/TR5000



Omnibot MK II



Omnibot MK II



Omnibot 5402



Omnibot 5402

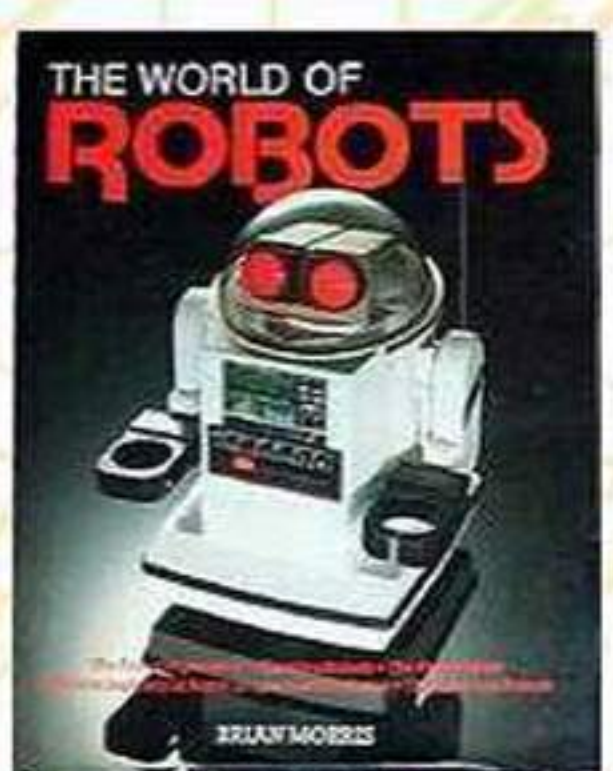

Omnibot 5402



Omnibot MK II



Omnibot MK II



Omnibot Fan Book



Omnibot Advertisement

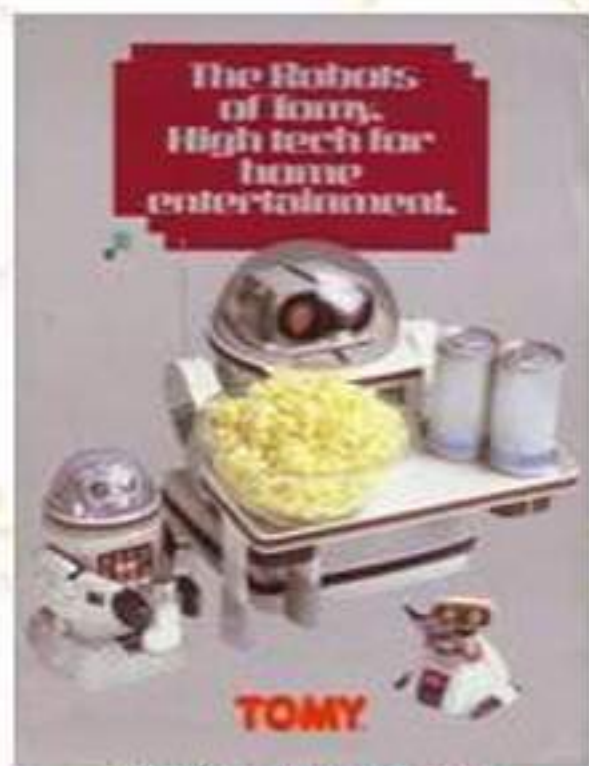

Omnibot Advertisement



Tomy Advertisement



Tomy Advertisement



Tomy Advertisement



Tomy Advertisement



Omnibot 5402



Omnibot Series



Tomy Omnitbot Family



Tomy & Omnitbot Robot



Omnibot MK II



Omnibot MK II



Omnibot Manual



Omnibot Manual (German)



Omnibot MKII Manual (Japan)



Omnibot Manual (Japan)



TOMY CORPORATION

We Value Your Opinion!

At Tomy we are continuously striving to meet the needs and interests of the people who buy our toys and games.

By filling out the brief, unannounced questionaire on the back of this book you can help us to do this. Any comments you would like to place about our toys or toys in general, should be much appreciated and will be read by our company's Management.

As always, Tomy's highest priority is bringing you and your family those toys and games which will provide you with the most satisfaction.

We thank you for your help in this ongoing effort and hope that your new toys will give you many happy hours of fun and enjoyment.

Marketing Research Department

Any questions? Please call toll-free:
California only 1-800-421-8439
Outside California 1-800-421-5337

Tomy Omnitobot Robot



Tomy Omnitobot Robot



Tomy Omnitobot Robot



Tomy Omnitobot Robot



Tomy Omnitobot Robot



Tomy Omnitobot Robot



Tomy Omnitobot Robot

OMNIBOT CONSUMER PARTS LIST & ORDER FORM

Part Name	Part No.	Price	Quantity
Head	001	1.50	
Body	002	2.00	
Arm	003	1.00	
Leg	004	1.00	
Wheel	005	0.50	
Motor	006	1.00	
Battery	007	2.00	
Charger	008	3.00	
Antenna	009	0.50	
Eye	010	0.50	
Mouth	011	0.50	
Hand	012	0.50	
Foot	013	0.50	
Wheel	014	0.50	
Motor	015	1.00	
Battery	016	2.00	
Charger	017	3.00	
Antenna	018	0.50	
Eye	019	0.50	
Mouth	020	0.50	
Hand	021	0.50	
Foot	022	0.50	
Wheel	023	0.50	
Motor	024	1.00	
Battery	025	2.00	
Charger	026	3.00	
Antenna	027	0.50	
Eye	028	0.50	
Mouth	029	0.50	
Hand	030	0.50	
Foot	031	0.50	
Wheel	032	0.50	
Motor	033	1.00	
Battery	034	2.00	
Charger	035	3.00	
Antenna	036	0.50	
Eye	037	0.50	
Mouth	038	0.50	
Hand	039	0.50	
Foot	040	0.50	
Wheel	041	0.50	
Motor	042	1.00	
Battery	043	2.00	
Charger	044	3.00	
Antenna	045	0.50	
Eye	046	0.50	
Mouth	047	0.50	
Hand	048	0.50	
Foot	049	0.50	
Wheel	050	0.50	
Motor	051	1.00	
Battery	052	2.00	
Charger	053	3.00	
Antenna	054	0.50	
Eye	055	0.50	
Mouth	056	0.50	
Hand	057	0.50	
Foot	058	0.50	
Wheel	059	0.50	
Motor	060	1.00	
Battery	061	2.00	
Charger	062	3.00	
Antenna	063	0.50	
Eye	064	0.50	
Mouth	065	0.50	
Hand	066	0.50	
Foot	067	0.50	
Wheel	068	0.50	
Motor	069	1.00	
Battery	070	2.00	
Charger	071	3.00	
Antenna	072	0.50	
Eye	073	0.50	
Mouth	074	0.50	
Hand	075	0.50	
Foot	076	0.50	
Wheel	077	0.50	
Motor	078	1.00	
Battery	079	2.00	
Charger	080	3.00	
Antenna	081	0.50	
Eye	082	0.50	
Mouth	083	0.50	
Hand	084	0.50	
Foot	085	0.50	
Wheel	086	0.50	
Motor	087	1.00	
Battery	088	2.00	
Charger	089	3.00	
Antenna	090	0.50	
Eye	091	0.50	
Mouth	092	0.50	
Hand	093	0.50	
Foot	094	0.50	
Wheel	095	0.50	
Motor	096	1.00	
Battery	097	2.00	
Charger	098	3.00	
Antenna	099	0.50	
Eye	100	0.50	
Mouth	101	0.50	
Hand	102	0.50	
Foot	103	0.50	
Wheel	104	0.50	
Motor	105	1.00	
Battery	106	2.00	
Charger	107	3.00	
Antenna	108	0.50	
Eye	109	0.50	
Mouth	110	0.50	
Hand	111	0.50	
Foot	112	0.50	
Wheel	113	0.50	
Motor	114	1.00	
Battery	115	2.00	
Charger	116	3.00	
Antenna	117	0.50	
Eye	118	0.50	
Mouth	119	0.50	
Hand	120	0.50	
Foot	121	0.50	
Wheel	122	0.50	
Motor	123	1.00	
Battery	124	2.00	
Charger	125	3.00	
Antenna	126	0.50	
Eye	127	0.50	
Mouth	128	0.50	
Hand	129	0.50	
Foot	130	0.50	
Wheel	131	0.50	
Motor	132	1.00	
Battery	133	2.00	
Charger	134	3.00	
Antenna	135	0.50	
Eye	136	0.50	
Mouth	137	0.50	
Hand	138	0.50	
Foot	139	0.50	
Wheel	140	0.50	
Motor	141	1.00	
Battery	142	2.00	
Charger	143	3.00	
Antenna	144	0.50	
Eye	145	0.50	
Mouth	146	0.50	
Hand	147	0.50	
Foot	148	0.50	
Wheel	149	0.50	
Motor	150	1.00	
Battery	151	2.00	
Charger	152	3.00	
Antenna	153	0.50	
Eye	154	0.50	
Mouth	155	0.50	
Hand	156	0.50	
Foot	157	0.50	
Wheel	158	0.50	
Motor	159	1.00	
Battery	160	2.00	
Charger	161	3.00	
Antenna	162	0.50	
Eye	163	0.50	
Mouth	164	0.50	
Hand	165	0.50	
Foot	166	0.50	
Wheel	167	0.50	
Motor	168	1.00	
Battery	169	2.00	
Charger	170	3.00	
Antenna	171	0.50	
Eye	172	0.50	
Mouth	173	0.50	
Hand	174	0.50	
Foot	175	0.50	
Wheel	176	0.50	
Motor	177	1.00	
Battery	178	2.00	
Charger	179	3.00	
Antenna	180	0.50	
Eye	181	0.50	
Mouth	182	0.50	
Hand	183	0.50	
Foot	184	0.50	
Wheel	185	0.50	
Motor	186	1.00	
Battery	187	2.00	
Charger	188	3.00	
Antenna	189	0.50	
Eye	190	0.50	
Mouth	191	0.50	
Hand	192	0.50	
Foot	193	0.50	
Wheel	194	0.50	
Motor	195	1.00	
Battery	196	2.00	
Charger	197	3.00	
Antenna	198	0.50	
Eye	199	0.50	
Mouth	200	0.50	
Hand	201	0.50	
Foot	202	0.50	
Wheel	203	0.50	
Motor	204	1.00	
Battery	205	2.00	
Charger	206	3.00	
Antenna	207	0.50	
Eye	208	0.50	
Mouth	209	0.50	
Hand	210	0.50	
Foot	211	0.50	
Wheel	212	0.50	
Motor	213	1.00	
Battery	214	2.00	
Charger	215	3.00	
Antenna	216	0.50	
Eye	217	0.50	
Mouth	218	0.50	
Hand	219	0.50	
Foot	220	0.50	
Wheel	221	0.50	
Motor	222	1.00	
Battery	223	2.00	
Charger	224	3.00	
Antenna	225	0.50	
Eye	226	0.50	
Mouth	227	0.50	
Hand	228	0.50	
Foot	229	0.50	
Wheel	230	0.50	
Motor	231	1.00	
Battery	232	2.00	
Charger	233	3.00	
Antenna	234	0.50	
Eye	235	0.50	
Mouth	236	0.50	
Hand	237	0.50	
Foot	238	0.50	
Wheel	239	0.50	
Motor	240	1.00	
Battery	241	2.00	
Charger	242	3.00	
Antenna	243	0.50	
Eye	244	0.50	
Mouth	245	0.50	
Hand	246	0.50	
Foot	247	0.50	
Wheel	248	0.50	
Motor	249	1.00	
Battery	250	2.00	
Charger	251	3.00	
Antenna	252	0.50	
Eye	253	0.50	
Mouth	254	0.50	
Hand	255	0.50	
Foot	256	0.50	
Wheel	257	0.50	
Motor	258	1.00	
Battery	259	2.00	
Charger	260	3.00	
Antenna	261	0.50	
Eye	262	0.50	
Mouth	263	0.50	
Hand	264	0.50	
Foot	265	0.50	
Wheel	266	0.50	
Motor	267	1.00	
Battery	268	2.00	
Charger	269	3.00	
Antenna	270	0.50	
Eye	271	0.50	
Mouth	272	0.50	
Hand	273	0.50	
Foot	274	0.50	
Wheel	275	0.50	
Motor	276	1.00	
Battery	277	2.00	
Charger	278	3.00	
Antenna	279	0.50	
Eye	280	0.50	
Mouth	281	0.50	
Hand	282	0.50	
Foot	283	0.50	
Wheel	284	0.50	
Motor	285	1.00	
Battery	286	2.00	
Charger	287	3.00	
Antenna	288	0.50	
Eye	289	0.50	
Mouth	290	0.50	
Hand	291	0.50	
Foot	292	0.50	
Wheel	293	0.50	
Motor	294	1.00	
Battery	295	2.00	
Charger	296	3.00	
Antenna	297	0.5	

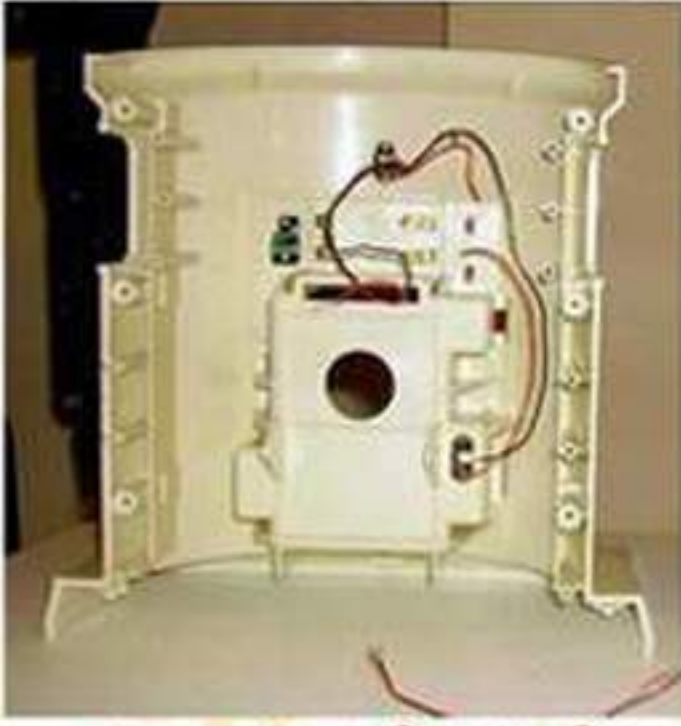

The Omnibot 2000[®] by Tomy[®]

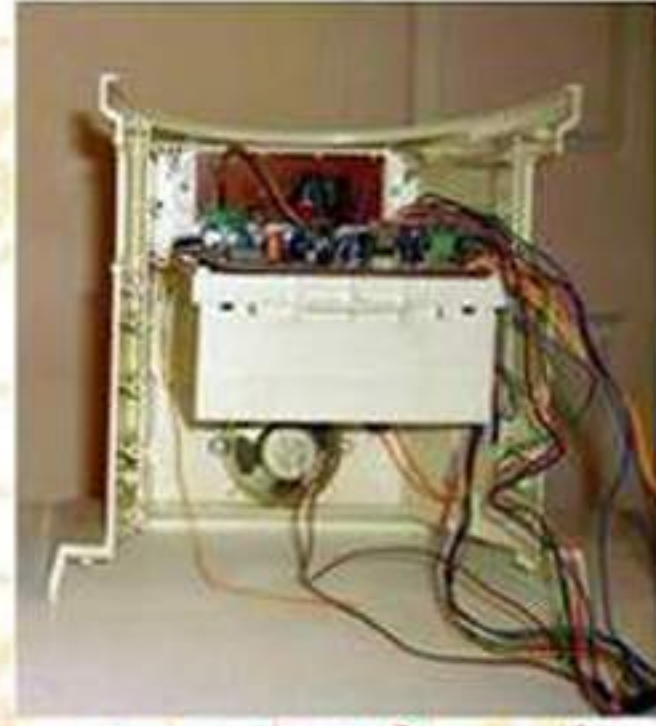

The Omnibot 2000[®] by Tomy[®]



The Omnibot 2000[®] by Tomy[®]



The Omnibot 2000[®] by Tomy[®]

Compare - The Omnibot 2000[®] by Tomy[®]



The Omnibot Hearoid / OOM[®] by Tomy[®]



The Omnibot Hearoid / OOM[®] by Tomy[®]



The Omnibot Hearoid / OOM[®] by Tomy[®]



The Omnibot Hearoid / OOM[®] by Tomy[®]

Compare - The Omnibot Hearoid[®] by Tomy[®]



The Omnibot 5402[®] by Tomy[®]



The Omnibot 5402[®] by Tomy[®]



The Omnibot 5402[®] by Tomy[®]



The Omnibot 5402[®] by Tomy[®]

Compare - The Omnibot 5402[®] by Tomy[®]



The Robie Sr.[®] by Radio Shack[®]

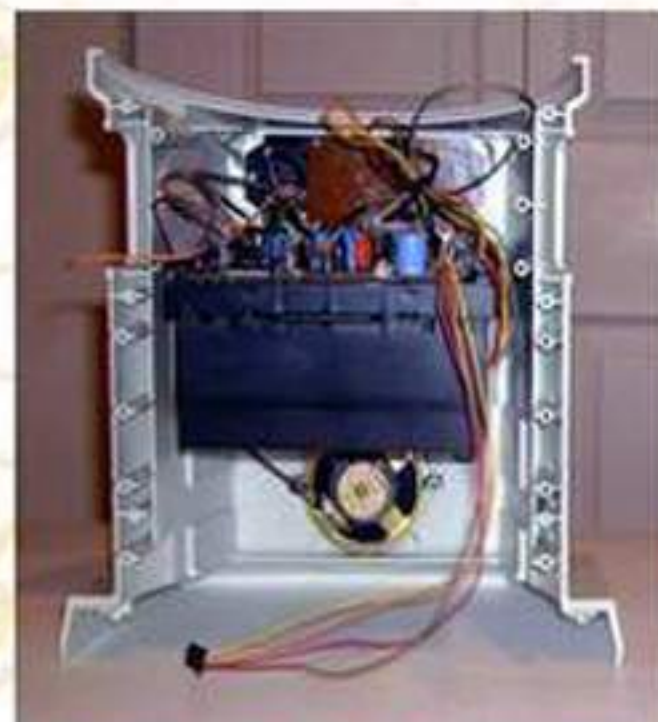

The Robie Sr.[®] by Radio Shack[®]



The Robie Sr.[®] by Radio Shack[®]



The Robie Sr.[®] by Radio Shack[®]

Compare - The Robie Sr.[®] by Radio Shack[®]



Omnibot 5402



Robie Sr.



Omnibot 5402



Omnibot 5402

* These are examples of the Circuit Boards in the Omnitron Family of Robots



Omnibot 2000
Circuit Board



Hearoid / OOM
Circuit Board



Robie Sr.
Circuit Board



Omnibot 5402
Circuit Board



Omnibot 5402 (Old)
Circuit Board

* These are examples of the Circuit Boards in the Omnitron Family of Robots



Omnibot 5402



Omnibot MK II



Robie Sr.

* All controllers are not interchangeable but these three are similar and could be modified. * Frequency



Omnibot 5402



Omnibot 5402



Omnibot 5402



Omnibot 5402



Omnibot 5402

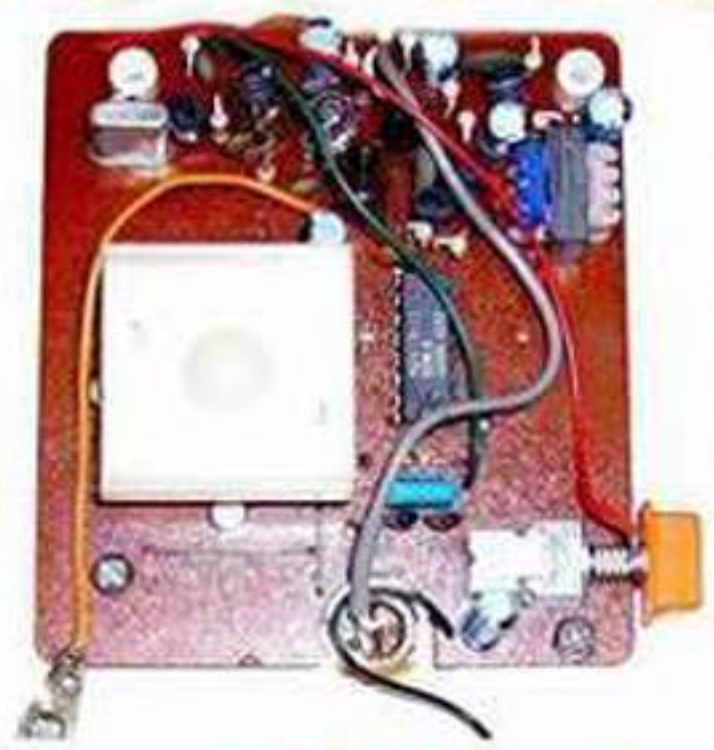

Omnibot 5402



Omnibot 5402

AM REMOTE CONTROL

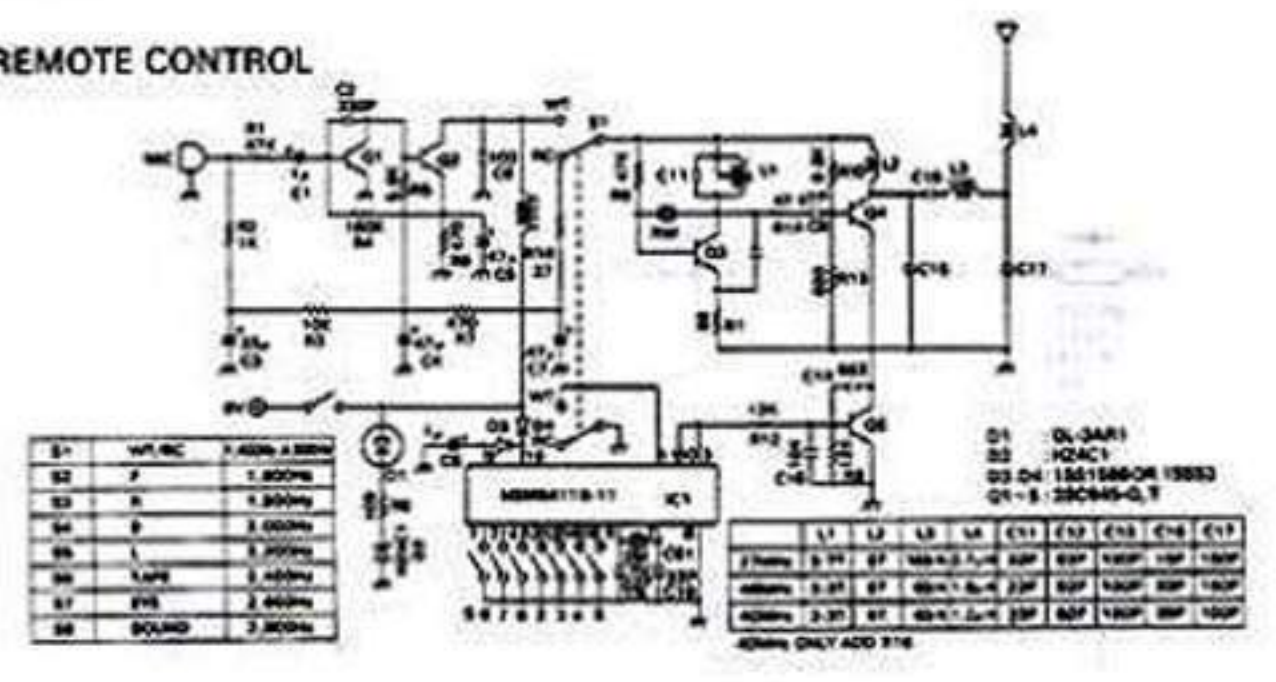

Omnibot 5402

* All controllers are not interchangeable but these three are similar and could be modified. * Frequency

REPAIR INFORMATION: Omnitron Repairs:

- [The Omnitron® Family Batteries and Chargers](#)
- [The Omnitron® Family Battery Contact Refurbished & Making Replacement](#)
- [The Omnitron® Family Battery Contact Replacement Procedure](#)
- [The Omnitron® Family Programming Tape Set-up](#)
- [The Omnitron® Family Circuit Boards Pictures](#)
- [The Omnitron® Family Repair Pictures](#)
- [The Omnitron® Family Accessories Information](#)
- [Omnitron® 2000 Tomy® Robot : Dissassembly and Assembly](#)
- [Omnitron® 2000 Tomy® Robot Tray Dissassembly and Assembly](#)
- [Omnitron® 2000 Tomy® Robot : Adding A Motorized Left Arm and Controls](#)
- [Omnitron® 2000 Tomy® Robot Arm Pictures](#)
- [Omnitron® 2000 Tomy® Robot Head, Door & Accessories Panel, External Jacks Panel Pictures](#)
- [Omnitron® 2000 Tomy® Robot Drive Train Pictures](#)
- [Omnitron® 2000 Tomy® Robot Questions & Answers](#)
- [Omnitron® 2000 Tomy® Robot Before and After Pictures](#)
- [Hearoid® TTC® Robot The Dissassembly and Assembly](#)
- [Hearoid or OOM® by Tomy® Home Base Replacement File in \(.JPG\) format](#)
- [Robie Sr.® by Radio Shack® Robot The Dissassembly and Assembly](#)
- [Robie Sr.® & The Omnitron 5402® Service Manual For Troubleshooting Robots \[Manual & Schematics \]](#)
- [The Omnitron 5402® Service Manual For Troubleshooting Robots \[Manual \]](#)
- [Omnitron® 5402 Robot by Tomy® Dissassembly and Assembly](#)
- [Omnitron® 5402 Robot by Tomy® Home Base Replacement File in \(.JPG\) format](#)
- [Omnitron® 5402 Robot by Tomy® Controller Circuit Boards](#)
- [Omnitron® 5402 by Tomy®, Robie Sr.® by Radio Shack® and Hearoid by TTC® Robot Drive Train](#)
- [Omnitron® 5402 by Tomy®, Robie Sr.® by Radio Shack® and Hearoid by TTC® Robot Robot Arms](#)
- [Omnitron® 5402 by Tomy®, Robie Sr.® by Radio Shack® Circuit Boards Schematics](#)
- [Omni Jr.® by Tomy®, Robie Jr.® by Radio Shack® Repair Pictures](#)
- [Omni Jr.® or Omnitron Jr.® by Tomy® Battery Replacement](#)
- [Robie Jr.® by Radio Shack® Battery Replacement](#)
- [Mr. D.J.® by Tomy® Disassembly & Assembly](#)
- [Dingbot® by Tomy® Disassembly & Assembly](#)
- [Verbot® ; Flipbot® ; Hootbot® ; Chatbot® by Tomy® Repair Pictures](#)
- [Armstrong™ Mobile Command Poweride Repairs Teardown - Scavengers Workshop](#)



HERE ARE SOME GUIDELINES FOR THOSE INDIVIDUALS WHO WANT TO REPAIR THEIR ROBOTS.

Robots - Repairs Information & Tips - The most disheartening thing to see is getting a robot (your) robot and finding that it does not work or is broken. The first thing is: Oh ????. Then! what do I do? The answer is, "GET IT FIXED or FIX IT". I have worked on, and have seen what passes for repairs on a lot of robots and my answer is: If you can get someone else (a professional) to work on it, do that. Send it out for repair before you break something else that is irreplaceable. Remember leave it alone.

Warning: you proceed at your own risk! With that in mind if you have to work on the robot, here are several suggestions that is listed as rules in repairing robots;

Rule 1: If you can get someone else (a professional) to work on it, do that.

Rule 2: Don't open the robot - If you can possibly avoid it. Put in strong, fresh batteries, do not use cheap batteries. Rechargeable are ideal because they guarantee a good current. Fiddle with the switch; you'll be surprised how often a toy burst in to life when the switch is in an in-between position.

Rule 3: Make a note of how it goes together. - Look carefully at the robot. Take pictures, lots of pictures, there is never enough. Make a written note of the wiring. You have no idea how difficult it can be to work out where a loose wire belongs. The information will also come in useful at a later date. You'll find that more wires come loose as you repair a toy and you'll soon forget where they go. The connections to the battery box. These frequently break loose, or the solder joints dry up with age. Repairs are simple: a good clean up of the contacts and loose wires elsewhere with a light touch of a soldering iron. Wires might be loose, but more likely is the problem of poor a contact between the switch components. A careful cleaning of accessible contacts can solve things. Don't reassemble the toy if further repair is required.

Rule 4: Robot + Water - Disaster Above all, don't immerse a robot in water, no matter how dirty it may be and how thoroughly you may intend to dry it. Water ruins the circuit board, card insulators that hold the battery contacts and various internal switching devices. You'd be amazed at how many people dunk the whole robot in bowl of hot soapy water.

Rule 5: Take your time and work slowly replacing what parts that is needed with similar parts, don't drill holes in the plastic or metal. Remember you have time to find or make the right parts. The robot has twenty three years (23) of waiting a few weeks would not hurt.

Rule 6: For Circuit Board Repairs use Rule 1. If you have completed the above and have been successful, Congratulations! if not go to Rule 1.

For the Tinkers and Hobbyist:

Now that I have given you some rules that is necessary when repairing your robot I will take you to the real world. The complete robots that has been in the family for years and in pristine condition is rare, and will cost you a great deal of money. Even then remember it is old and will have problems. For most of the robots when you buy, trade, get one, nine out of ten times it will be dirty, corroded and missing parts. I will focus on, and I am referring to, the larger robots including the plastic robots that need attention.

You will need several things to repair and rebuild your robot: A Multimeter, Digital Camera, Computer, Information, Tools, patience and the ability and dexterity (manual skills) to fix things electronically and mechanically and the time to find parts.

Or if you are extremely good, a small knife, screwdriver, pliers, file, chisel, small hammer, sandpaper, pencil and paper. Myself, I need all of the above, for I also use the camera and computer for other things. Remember there are no parts readily available for old robots.

- Step 1. The first thing you must do if you can is to temporary get it working. Once you do that then you can start.
- Step 2. Disassemble the robot completely, recording every step, and put the electronics in a separate place.
- Step 3. Clean all of the parts with the proper cleaners. (Remember plastic and metals need different cleaners.)
- Step 4. Clean the electronics and circuit boards. (There are many processes in cleaning electronics and you should look up the procedures and cleaners.)
- Step 5. Reassemble the robot reversing the recorded steps.
- Step 6. At this stage you are ready to troubleshoot the robot to get it working.
- Step 7. Listed above are several procedures for disassembly and assembly.

There is no warranty expressed or implied with this procedure. By using any information from this web site, you agree not to hold responsible this site, me, nor any of its representatives, for any injuries and/or damages, both physical and/or psychological, that may arise from the use and/or misuse of anything derived from this site. The user further agrees that such information/pictures does not constitute any guarantee of accuracy, safety or reliability, and that cannot be held responsible for any way. The user agrees to proceed at their own risk.



Original Omnibot - 2.76 X 1.85 X 4.15
Omnibot 5402 - 6v 4.0 ah
Sealed Lead Acid Battery



Original Omnibot - 2.76 X 1.85 X 4.15
yuasa np-4-6w 6v 4.0 ah
Sealed Lead Acid Battery



Replacement: B.B. Battery BP5-6
Sealed Lead Acid Battery
2.76" x 1.85" x 4.10"



Replacement: CSB
GP 645 6V 4.5Ah
Sealed Lead Acid Battery



Replacement: WERKER WKA6-5F
6V 5Ah AGM
Sealed Lead Acid Battery

The above Battery is for the Tomy Robot Family. Special attention must be taken for the plug polarity. Here are some web sites to look for batteries:



Replacement: UB 645 - 6V 4.5AH
70mm (2.76") X 47mm (1.85") x 101mm
(3.98")
Sealed Lead Acid Battery



Replacement: UB 1280
12V 5Ah
Sealed Lead Acid Battery

The above Battery is for the Tomy Armstrong Mobile Command Poweride - 6026. Special attention must be taken for the plug polarity.



Replacement: TXR-002



Battery for TXR-002
Tomy Zenergy 6N-1201A
6 Sanyo N-120TA ni-cad cells making
7.2 volts at 120mah.



Charger for TXR-002
Tomy Zenergy 6N-1201A



Charger for TXR-002
Tomy Zenergy 6N-1201A

The above Battery and Charger is for the Tomy TXR-002 Special attention must be taken for the plug polarity.

Battery Chargers: Special attention must be taken for the plug polarity. (Original & Replacement Equipment)



Omnibot 2000
input 240 V 50 Mh
6VDC 400ma



Omnibot
Tomy 2EX-5441
6VDC 300ma



Hearoid / OOM
TAMRADIO
25A-3532 400ma



Omnibot MK II
TAMRADIO
29A-4135 400ma



Robie Sr.
TC-604U
6VDC 600ma



Omnibot Replacements
Radio Shack Battery Charger
60-2398 6VDC 600ma

Battery Chargers will range from 300ma to 600ma for lead acid batteries. See battery specifications and their recommendations. Special attention must be taken for the plug polarity.

Plugs and Jacks Polarity: Special attention must be taken for the plug polarity. (Original Equipment)

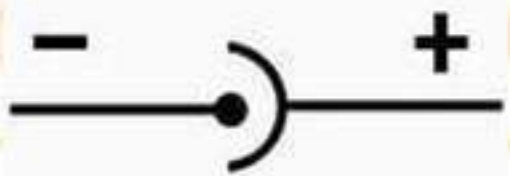

2.5 mm CO-AX Plug
Radio Shack Robie Sr
Battery Charger 60-2398
6VDC 400 ma

Omnibot Series - Omnibot 5402; Hearoid;
Omnibot MK II, Omnibot 2000 5405
TAMRANDIO 25A-3532 - 6VDC 400 ma



You can program your Omnibot[®] 2000, Omnibot[®] 5402, Hearoid[®] and Robie[®] Sr. Robots in three different ways. One is from the Robot itself, two is from a Dual Cassette Player and Recorder which is (Analog to Analog) or the third way is from a Computer to a Cassette Recorder, that is from (Digital to Analog). Of the three the first and second way is inexpensive, quick, simple and less prone to errors. The first way is contained in the users manual and is under the download page. I will show both the second and third ways here. At the bottom of this page contain links to files that can be downloaded. This is an ongoing process and the files will be upgraded as improvements are made.

**Cassette Player and Recorder Dual Track
Analog to Analog**

**Computer to Cassette Recorder
Digital to Analog**

**Computer to Robot or CD
Computer Programming**



Information

Information

Free Computer Program Available

Demo and Operating Program files for the Omnibot[®] 2000, Omnibot[®] 5402, Hearoid[®] and Robie[®] Sr. Robots is stored in wav format (1st Copy). You can download and copy these files directly to a cassette, and use them to check your robot.

Download File Size 6.9 MB .mp3

Download File Size 8.2 MB .wav

Under Construction

Under Construction



Omnibot[®] 2000 - Demo Tape and Programing from The Old Robots - 4/1/2015

Robie[®] Sr. from Radio Shack[®] - Original Demo Tape and Programing - 2/1/2008

Omnibot[®] Demo Tape - Tape and Programing from The Old Robots - 2/1/2008

Hearoid[®] Demo Tape - Tape and Programing from The Old Robots - 2/1/2008

Please give feedback to improve these Recommendations and Files for the next user.

There is no warranty expressed or implied with this procedure. By using any information from this web site, you agree not to hold responsible this site, me, nor any of its representatives, for any injuries and/or damages, both physical and/or psychological, that may arise from the use and/or misuse of anything derived from this site. The user further agrees that such information/pictures does not constitute any guarantee of accuracy, safety or reliability, and that cannot be held responsible for any way. The user agrees to proceed at their own risk.



Cassette Player and Recorder Dual Track

This process uses a Dual Cassette Player and Recorder which is (Analog to Analog). This way is inexpensive, quick, simple and less prone to errors. There is a BUT You will need an Originally Recorded Cassette Tape.

Now you can program your Omnibot[®] and have it work without a controller. You can take a pre-existing program tape and create a second tape to run your Omnibot[®] Robot with new different conditions.

This process is not new, it has always been available but is a little used function. A whole world has re-opened for the Omnibot[®] owners.

You can move into a world where audio tone, sequence and timing, with simple editing and recording, can be used to create new program tapes that will breath life into your Omnibot[®] and let it become your stand alone Robot.

To program your robots you will need an original recorded cassette tape and a Dual Record and Play Cassette Player. Omnibot[®] Controller Welcome! But Not Necessary. Use your Demo Cassette Program to check your Omnibot[®] Robot and your Operating Programs to have it work without a controller.

The following are some of the recommendations to copy and create programmed tapes. This has been successfully done but is not always 100% successful. Follow the recommendations and the steps and you should get the same results. (Remember different Robots and Cassette Recorders can act different.)

Please give feedback to improve these Recommendations and Files for the next user.

SOFTWARE

- NONE IS NECESSARY
- Record from the original tape, stopping and starting the recorder, while you select from the original tape what you want to record. This will take some trial and setting until you get the experience.
- If you use software to monitor what you are doing, use State of the Art Recording Technology Software
 - WavePad Recording Technology - <http://nch.com.au/wavepad/index.html>
 - &/or
 - Freecorder Recording Technology - <http://www.freecorder.com/>
 - READ THE INSTRUCTIONS AND INFORMATION THAT COMES WITH THIS SOFTWARE.
 - If you are recording the Omnibot Mono tape, be sure to record in Mono mode.
 - A recording made with a 44100 sampling rate will carry frequencies up to 20000 Hz.

HARDWARE

- A good Dual Mono or Stereo Cassette Player and Recorder.
- A high quality tape is necessary.
- The Omnibot[®] Robot in good working condition.

PROCESS

- Cassette Player & Recorder - Hook up the cassette player and recorder, and test the process of recording between cassette tapes.
- Omnibot[®] Robot - Insert a cassette tape in the Omnibot[®] Robot and following the instructions ⁽¹⁾ in that manual.
- Record and create a programmable tape. (If you have a controller, if not get a tape from someone that can record and has a controller.)
- Record from the original tape, stopping and starting the recorder, while you select from the original tape what you want to record. This will take some trial and setting until you get the experience.
- Insert the programmed cassette into the Omnibot[®] robot and activate using the instructions ⁽¹⁾ that come with the Omnibot[®]

⁽¹⁾ Use and follow the instructions and procedures in the Omnibot[®] 2000, Omnibot[®], Hearoid[®] and Robie Sr.[®] Operating Manuals to create your program tape.

There is no warranty expressed or implied with this procedure. By using any information from this web site, you agree not to hold responsible this site, me, nor any of its representatives, for any injuries and/or damages, both physical and/or psychological, that may arise from the use and/or misuse of anything derived from this site. The user further agrees that such information/pictures/software does not constitute any guarantee of accuracy, safety or reliability, and that cannot be held responsible for any way. This software is not supported. The user agrees to proceed at their own risk.



Computer to Cassette Recorder

I have an Omnibot but lost my controller and my Omnibot[®] does not work without it. Not True! Download your Demo Program to check Omnibot[®] Robot and Operating Programs to have it work without a controller in different conditions. To program your robots you will need both hardware and software.

Omnibot[®] Controller Welcome! But Not Necessary. You can also make your own tapes without a controller by just downloading a program and modifying it. This is not new it has always been available but is a little used function.

A whole world has re-opened for the Omnibot[®] owners. You can move into a world where audio tone, sequence and timing, with simple programs on your computer, can be used to create cassette tapes. This programming will breath life into your Omnibot[®] and let it become your stand alone Robot.

For you to copy and edit the program tapes from your robot with your computer you must first recognize that your computer must be set up to handle audio files. Computers and there associated hardware (Video and Audio boards and drivers) do not always support the whole range with quality reproduction of your recorder programs. You need special recording software and hardware with conversion plugs and jacks for this process.

The following is recommended if you want to successfully transfer files from your audio cassette to and from your computer. Examples are shown and specific hook-up for different equipment and software will vary.



Example # 1 Mono input



Example # 2 Mono input



Example # 3 Stereo input



Example # 4

The following are some of the recommendations to copy and create programed tapes. This has been successfully done but is not always 100% successful. Follow the recommendations and the steps and you should get the same results. (Remember different computers act different.)

Please give feedback to improve these Recommendations and Files for the next user.

SOFTWARE

- Use State of the Art Recording Technology Software
 - WavePad Recording Technology - <http://nch.com.au/wavepad/index.html>
 - &/or
 - Freecorder Recording Technology - <http://www.freecorder.com/>
- **READ THE INSTRUCTIONS AND INFORMATION THAT COMES WITH THIS SOFTWARE.**
- If you are recording the Omnibot Mono tape, be sure to record in Mono mode.
- A recording made with a 44100-sampling rate will carry frequencies up to 20000 Hz.
- Record and edit the tape before saving. Save only once from the original in MPG -wav format, because you lose audio quality every time you save the file.

HARDWARE

- A good Mono or Stereo Cassette Recorder with an Auxiliary (AUX.) input.
- A high quality tape is necessary.
- The appropriate shielded plugs, jacks and cables for the recorder. **The key word is shielded.**
- The computer.

PROCESS

- Computer & Recorder - Hook up the cassette recorder to the computer and test the process of recording to and from the computer.
- Omnibot[®] Robot - Insert a cassette tape in the Omnibot[®] Robot and following the instructions ⁽¹⁾ in that manual. Record and create a programmable tape.
- Transfer the cassette to the recorder and then transfer the program to the computer with the recommended software.
- Record and edit the cassette tape on the computer and save it directly to the recorder, then save it to the computer.
- Insert the programmed cassette into the Omnibot[®] robot and activate using the instructions ⁽¹⁾ that come with the Omnibot[®] robot.

Demo and Operating Program files for the Omnibot[®] 2000, Omnibot[®] 5402, Hearoid[®] and Robie[®] Sr. Robots is stored in wav format (1st Copy). You can download and copy these files directly to a cassette tape, and use them to check your robot.

⁽¹⁾ Use and follow the instructions and procedures in the Omnibot[®] 2000, Omnibot[®], Hearoid[®] and Robie Sr.[®] Operating Manuals to create your program tape.

There is no warranty expressed or implied with this procedure. By using any information from this web site, you agree not to hold responsible this site, me, nor any of its representatives, for any injuries and/or damages, both physical and/or psychological, that may arise from the use and/or misuse of anything derived from this site. The user further agrees that such information pictures does not constitute any guarantee of accuracy, safety or reliability, and that cannot be held responsible for any way. The user agrees to proceed at their own risk.



Special Thanks go to Avery Pennarun from Apenwarr, for now you can utilize several means to control the Robie Sr. ® Robot. I have utilized his program to create the Computer Program and Control for the Omnibot 5402 ® Robots. All of the following programs modifications/examples has been created, tested, completed, and do work.

EXAMPLES:

- a. With the Original Controller. (See the Operating Manual)
- b. Without a Controller, but with Original Tape. (Analog to Analog)
- c. Without a Controller, with original tape from the internet. (Digital to Analog)
- d. With/Without controller with computer on-line or off-line. (Computer Programming and Control - Preferred Method)



(figure 1)

COMBINATIONS:

- d1. With the Original Controller.
- d2. With a 49 MHz Two Way Radio. (Modifications will be necessary)
- d2-a Operating R/C frequency:
(Remote 3 Frequencies: 49.860 Mhz (US), 27.145 Mhz (Europe), 40.680 Mhz (TAL))
- d3. With a Computer with #d1 or #d2 and/or #d4, #d5, #d6. (Software will be necessary)
- d4. With the Internal Cassette with #d1 or #d2 or #d3.
- d5. With a External Cassette with #d1 or #d2 and #d3.
- d6. With a External CD with #d1 or #d2 and #d3.
- d7. With any or all of the combinations above.

d1. With the Original Controller.

A. Robie Sr. ® or Omnibot 5402 ® works with his controller (figure 6). You could record a program onto a cassette tape (figure 8, 9) and play it back, and he'd do what you programmed him to. You can modify the controller and move into the world of computers and programming, without the robot activated.

d2. With a 49 MHz Two Way Radio. (figure 2, 3) (Modifications will be necessary and use of (#d3).

Note: (d2-a) Operating R/C frequency: (The Remote came in three (3) Frequencies: 49.860 Mhz (US), 27.145 Mhz (Europe), 40.680 Mhz (TAL)). This modification does not deal with the Europe (EU) or Asia (TAL) frequencies, due to the fact that the equipment and robots was not available. However the software should work if you can obtain a Two Way Radio operating on those frequencies.

A: What to do for present day control? Get a 49 MHz Two Way Radio that broadcast and received on the same frequency as Robie Sr. ® or Omnibot 5402 ® to replace the original controller that will work with your robot. Add a switch and an audio jack in parallel with the microphone, so that you can switch between the two, thus allowing you to input and transmit whatever signal you want to over the airwaves to control Robie Sr. ® or Omnibot 5402 ®

d3. With a Computer with (#d1) or (#d2) and/or (#d4, #d5, #d6) . (Software will be necessary)

A. With the computer and software you can run to the external cassette (#d5) or the CD recorder's (#d6) (figure 4, 5) or through the original controller or the 49 MHz Two Way Radio directly to the robot, and/or to the internal cassette (#d4), or all of the above. What this gives you is the ability to create a cassette tape to the robot without the controller directly through cables and adapters (figure 7) from the computer. With the controller or the 49 MHz Two Way Radio this can bring you into the age of CD's that is readily available today and eliminate the need for the cassette. Audio cassettes are not readily available today, and not easy to hook up to a computer and connect to the internet to read and write.

Your upgrade is now complete and your next step is to downloaded a .wav recording of Robie Sr. ® or Omnibot 5402 ® original demo tape (it's important to use plain .wav format, as mp3 compression risks disrupting the pure signal) and burned it to a CD.

To resolve these issues you need a means of communicating, recording, playing and programming.



49 MHz FM Two Way Radio
(figure 2)



49 MHz FM Two Way Radio
(figure 3)



CD Player
(figure 4)



Two Way Radio & CD Player
(figure 5)



Robie Sr.® or Omnibot 5402® Controller (figure 6)



Demo Tape and Cables (figure 7)



Cassette Tape (figure 8)



Cassette Recorder & Player (figure 9)



Cassette Recorder & Player (figure 10)

SOFTWARE:

The software program is an extremely basic form of frequency shift keying where there is one frequency for each button on the remote control. The sound would be emitted from the remote for as long as you held down the button or pulled the joystick in a particular direction.

From the Robie Sr.® or Omnibot 5402® 1980's remote control, the control mechanism is still exactly how most remote control devices work to this day.

The remote control would form the sounds it wanted to send, then modulate them to 49 MHz FM (the usual frequency used by consumer remote control devices in the past). The robot would receive the signal, demodulate it back to listenable sounds, then recognize the different frequencies.

In the case of a tape program, it would simply skip the modulation/demodulation steps and process the sounds directly from the tape.

Computer Controller Programs

Programming: Add a computer and software. (figure 11, 12)

Computer Control is the last step: Once you have a digital file and the ability to transmit from any audio equipment you want, the real answer is clear: computer control!

Use the application in Delphi, thanks to the TJvWavePlayer component in the awesome open source JVCL library by Avery.

After clicking the "Sound On" button, any sound from my computer can now be beamed into Robie Sr.® or Omnibot 5402®, so I can have him move around and play astonishingly - low - fidelity MP3s at people!



(figure 11)



(figure 12a)



(figure 12b)

DOWNLOAD :

You can download the software in the zip format for: [Robie Sr.® Computer Controller Program](#)

You can download the software in the zip format for: [Omnibot 5402® Computer Controller Program](#)

For further information on the Robie Sr.® or Omnibot 5402® Computer Controller Conversions, please Email me.

There is no warranty expressed or implied with this procedure. By using any information from this web site, you agree not to hold responsible this site, me, nor any of its representatives, for any injuries and/or damages, both physical and/or psychological, that may arise from the use and/or misuse of anything derived from this site. The user further agrees that such information/pictures/software does not constitute any guarantee of accuracy, safety or reliability, and that cannot be held responsible for any way. This software is not supported. The user agrees to proceed at their own risk.



(Before) Bad Original

The above figure is the contacts in the Omnibot 5402 that needs to be replaced. They are corroded and not usable. (Replace)



(After) Replacement

The above figure is the contacts in the Omnibot 5402 that has been replaced.



(Before) Bad Original

The above figure is the contacts in the Omnibot 5402 that needs to be replaced. They are corroded and not usable. (Replace)



(After) Replacement

The above figure is the contacts in the Omnibot 5402 that has been replaced.

Refurbished - Replacement Contact for the Omnibot Family Robots



Bad Original (Replace)

The following figure on the left is contacts taken from a Omnibot 5402 Controller that is corroded and not usable. It has to be replace.



Refurbished Original

The following figure on the left is contacts taken from a Omnibot 5402 Controller that was corroded and not usable. It has been refurbished and can now be reused.

NEW - Replacement Contact for the Omnibot Family Robots



Step # 1

Step #1. Omnibot 5402 contacts created from scratch. It uses contact material to create the blank.

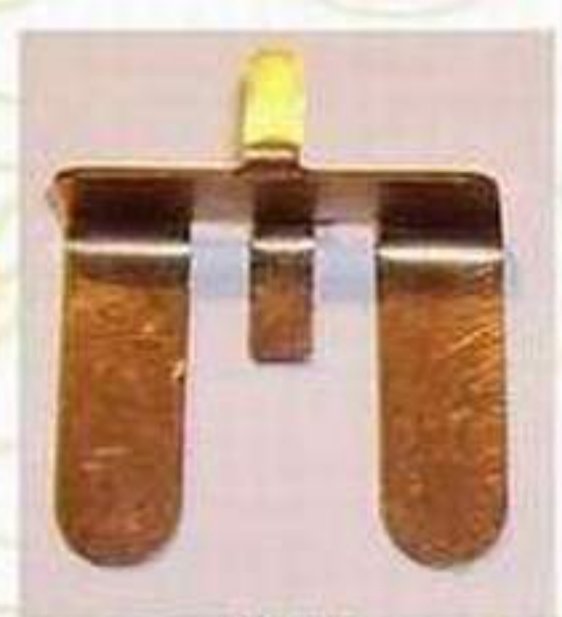

Step #2

Step #2. Bend the contacts at the appropriate points



Step #3 & #4

Step #3. Using a punch indent the contact and then using a drill with a proper bit drill the holes in the contact.

Step #4. Heat treat the contact. You now have a finished part.

Replacer



The following figure on the left is contacts taken from a Omnibot 5402 Controller that was corroded and not usable. It has been refurbished and can now be reused.



Step #1. Cut the contacts at the appropriate points



Step #2. Using a punch indent the contact and then using a drill with a proper bit drill the holes in the contact. You now have a finished part.



Use Brass 2/56 HEX MACH SC screws and nuts to fasten the battery contacts.



This process Addresses the Mechanical Disassembly of the Robot and does not address the Electronics. Accompany this Procedure is additional pictures that you can expand to see more details as needed. This Robot has IC's and Transistors and are of the earlier designs. Static discharge can damage the electronics. It is recommended that you have and use a Static grounding wrist strap.

Replacing Hearoid Omnibot Battery Contacts.

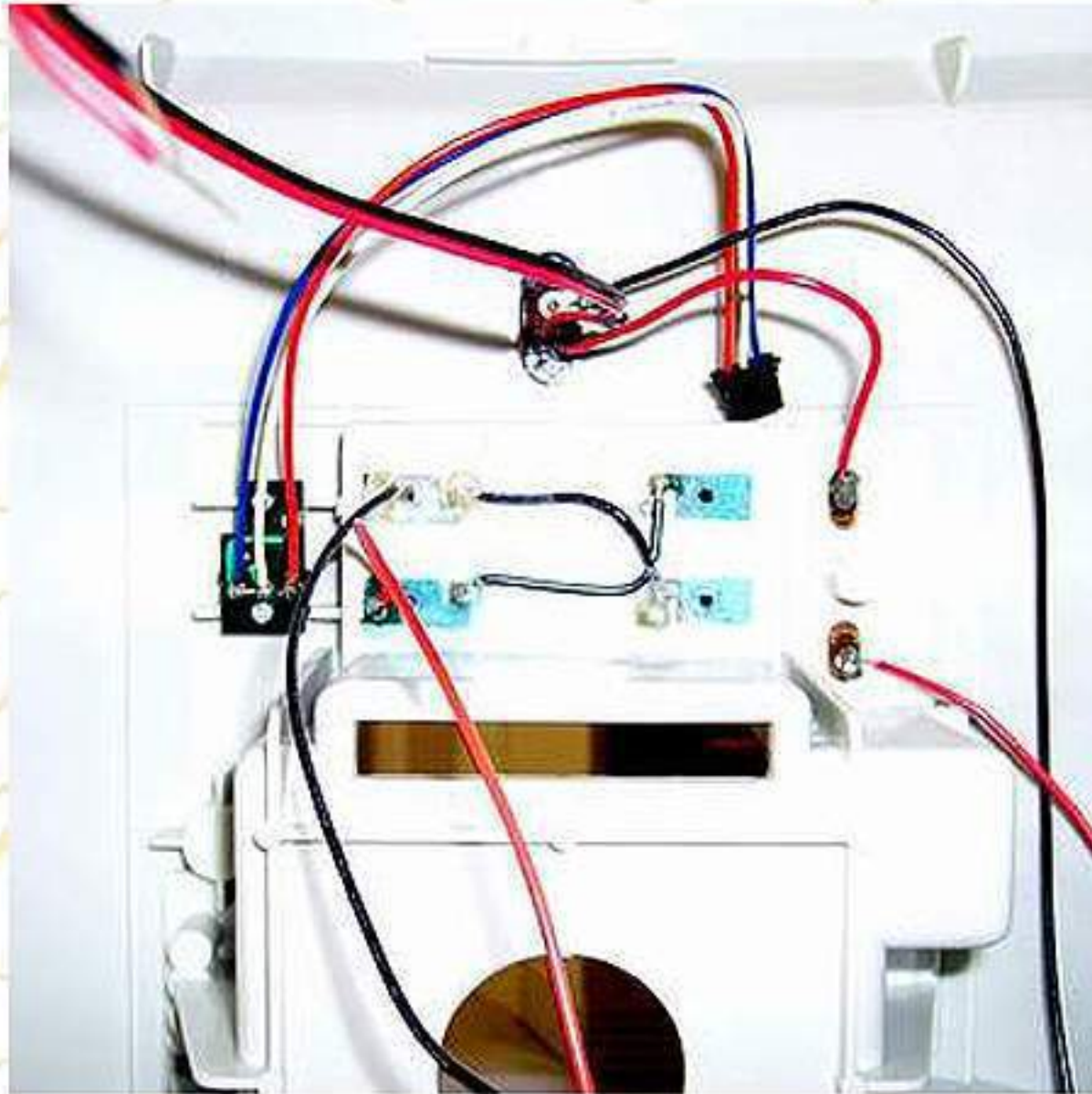

1. Check the wires to insure that you know how they are hooked up. These batteries are wired in parallel.



2. Make sure that the batteries are removed from the rear housing.

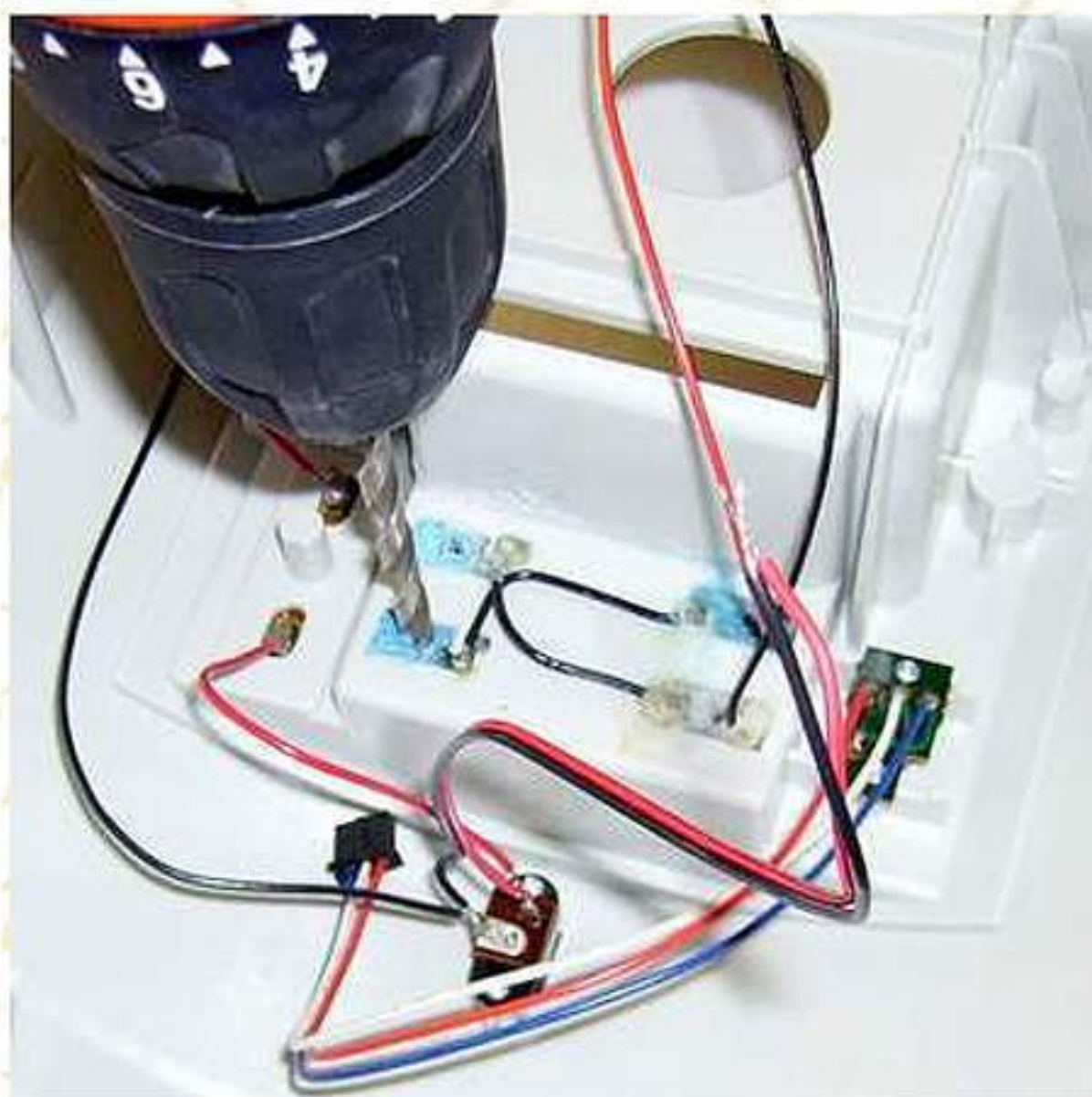

3. Place the housing flat on the table. Use a oversize drill bit and lightly drill the rim off the eye lit that hold the battery contacts in place.

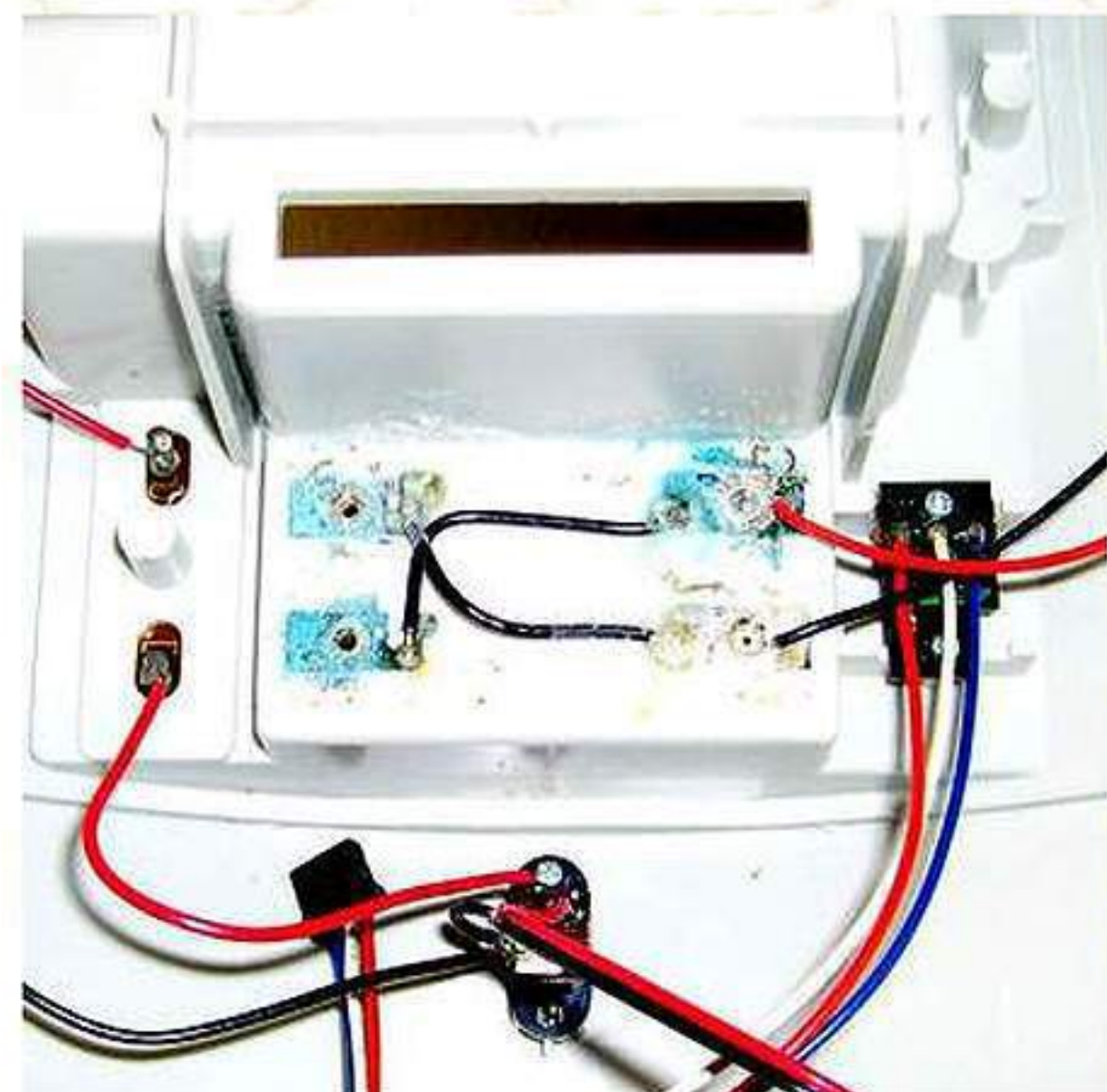

4. DO NOT drill through the battery contacts or the plastic housing.

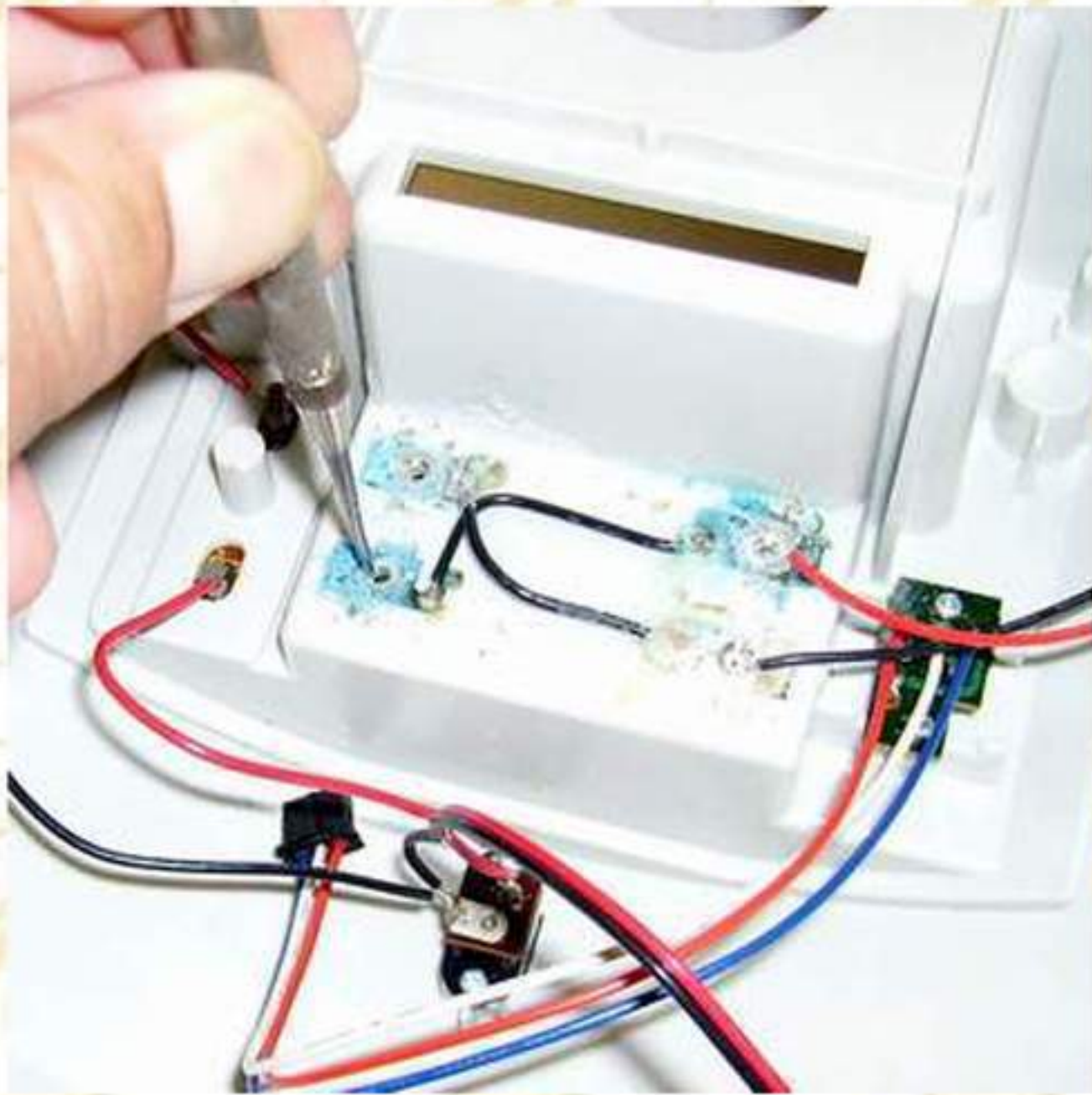

5. Once the eye lit ridge is removed take a punch smaller than the hole and gently tap all four of the eye lit out.

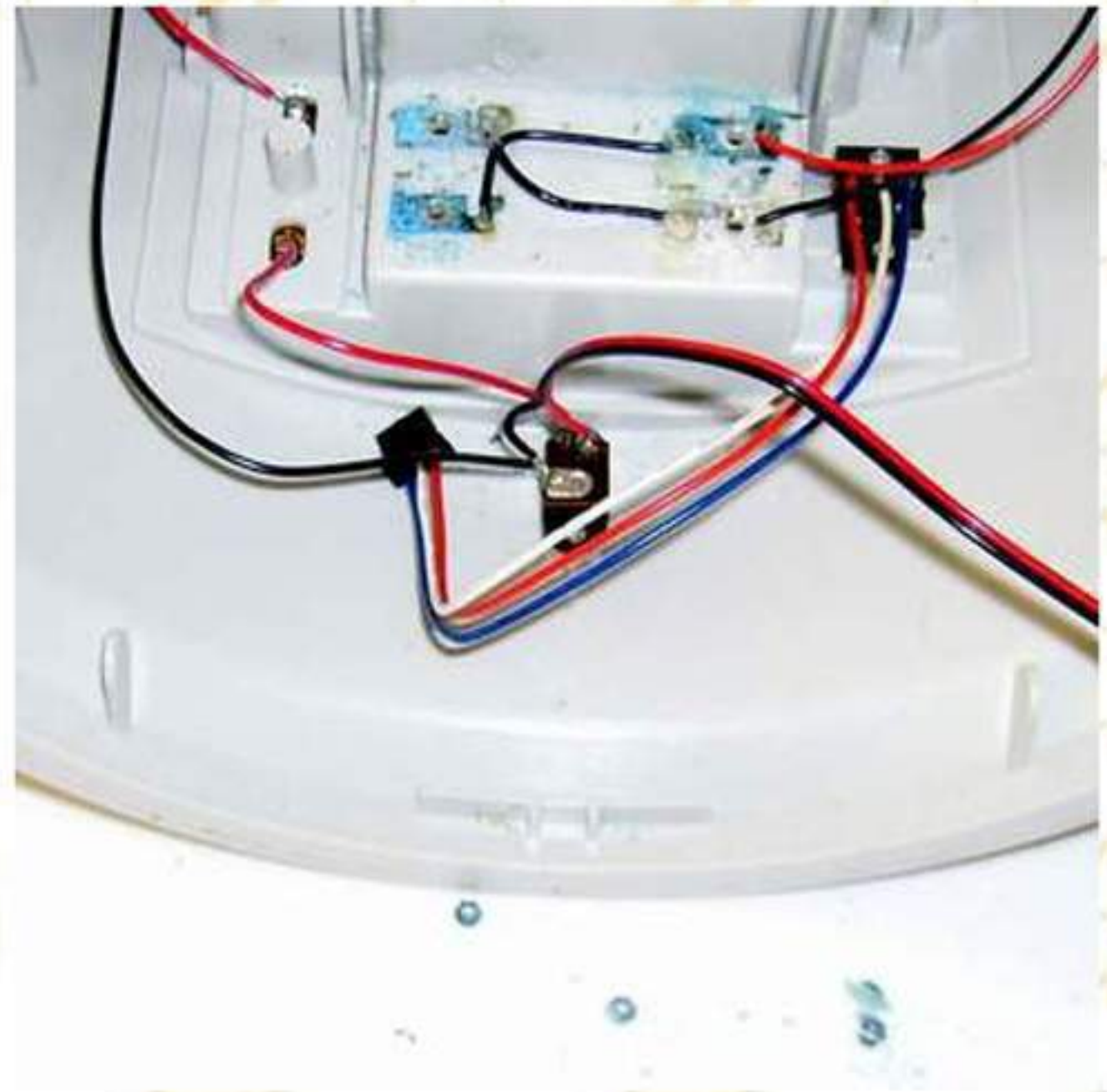

6. This picture shows the eye lit removed from the housing and battery contacts.



7. Gently pry the battery contacts out.

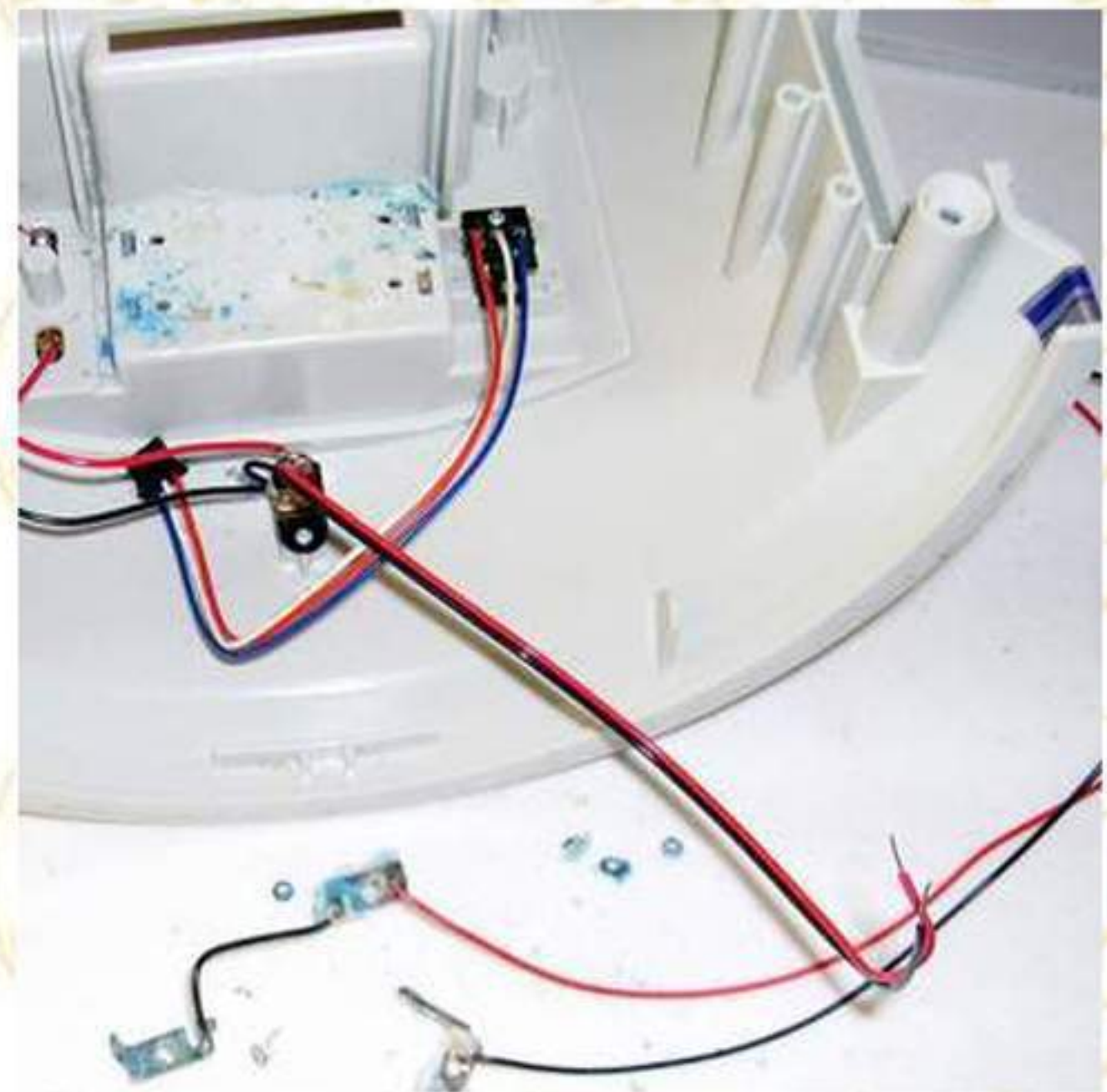

8. Remove the battery contacts and wires and plug.

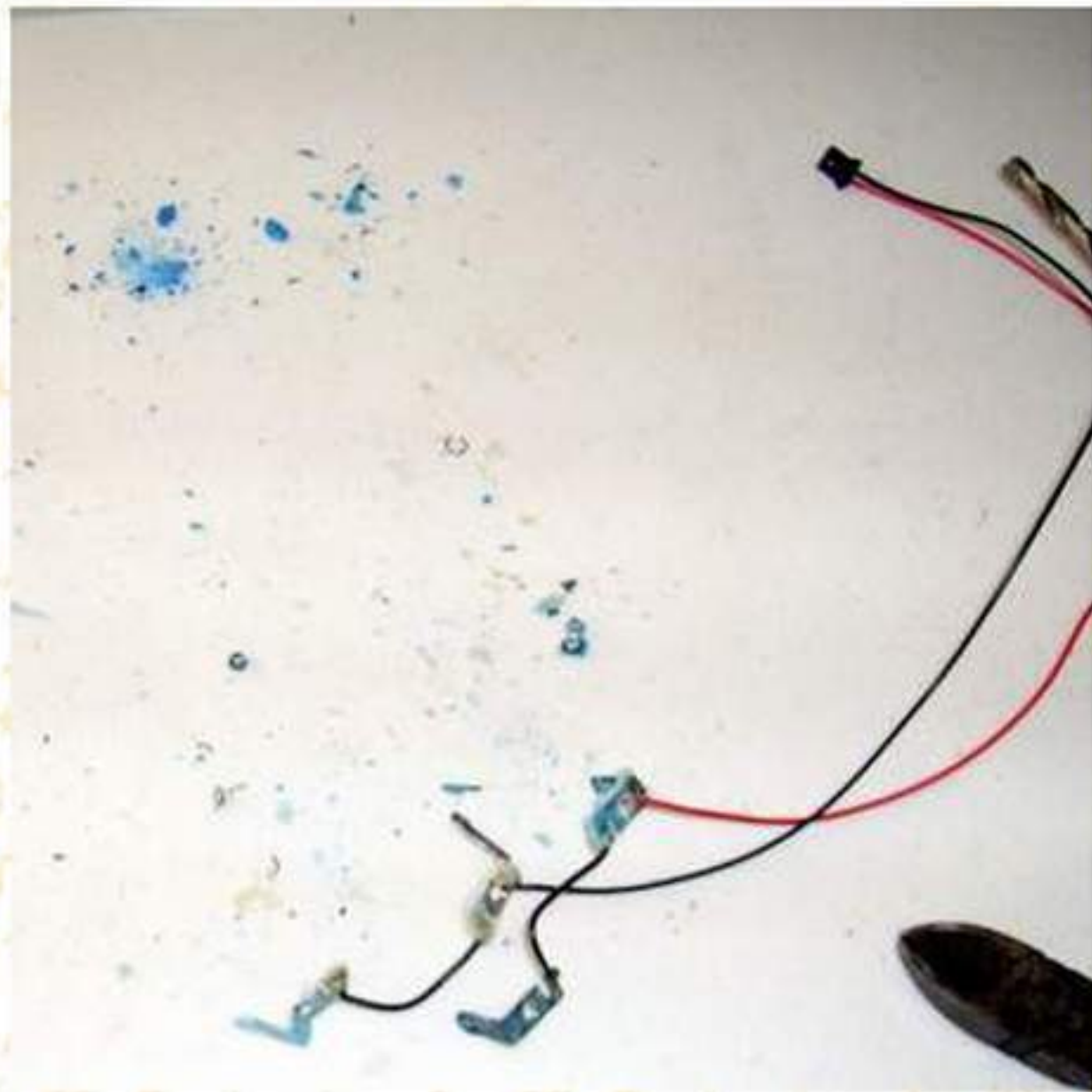

9. This is what the contacts with wire and plug will look like, Replace the battery contacts and solder the wires to the contacts.

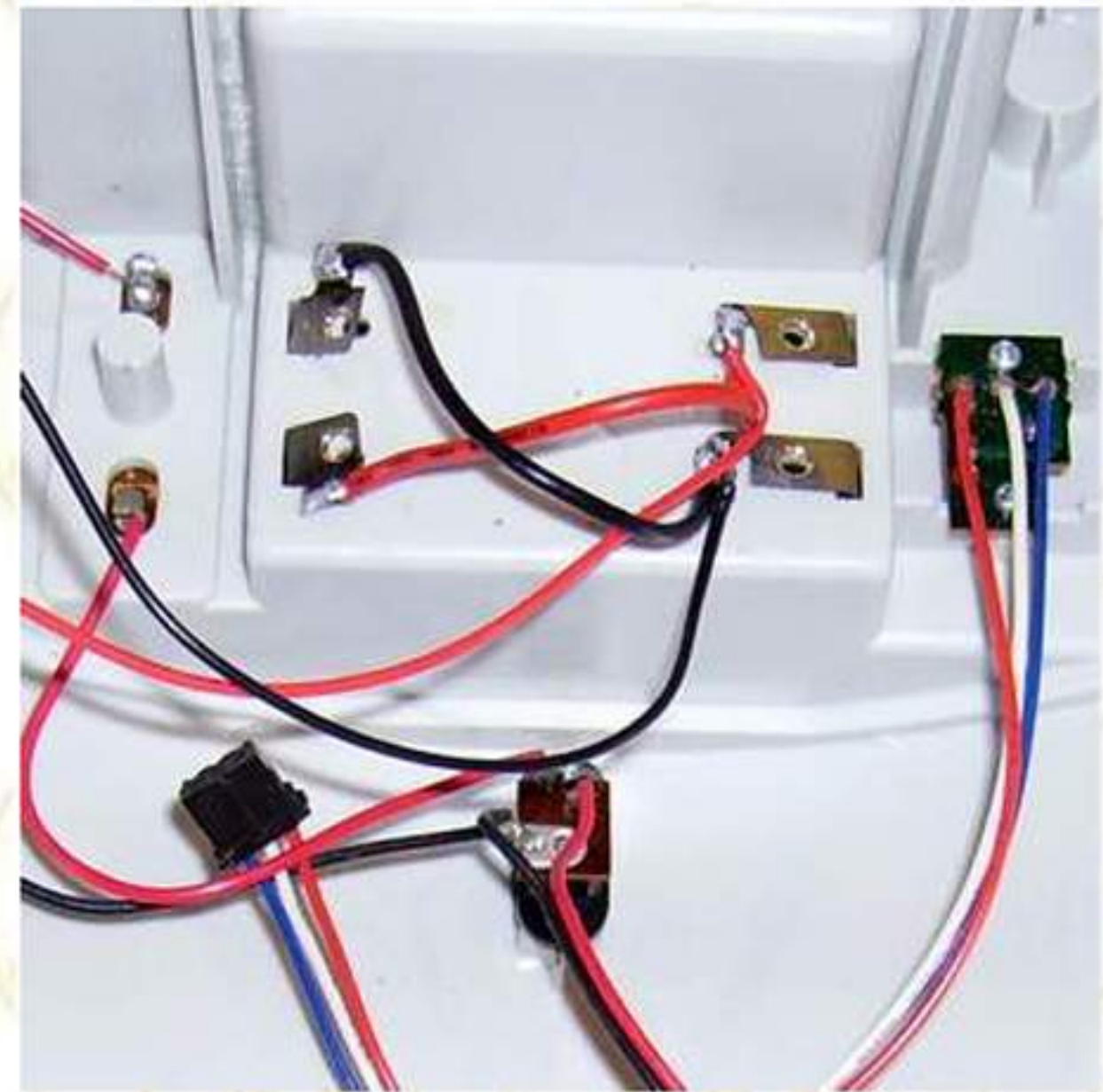

10. After cleaning the housing reinsert the new battery contacts and wires into the housing.

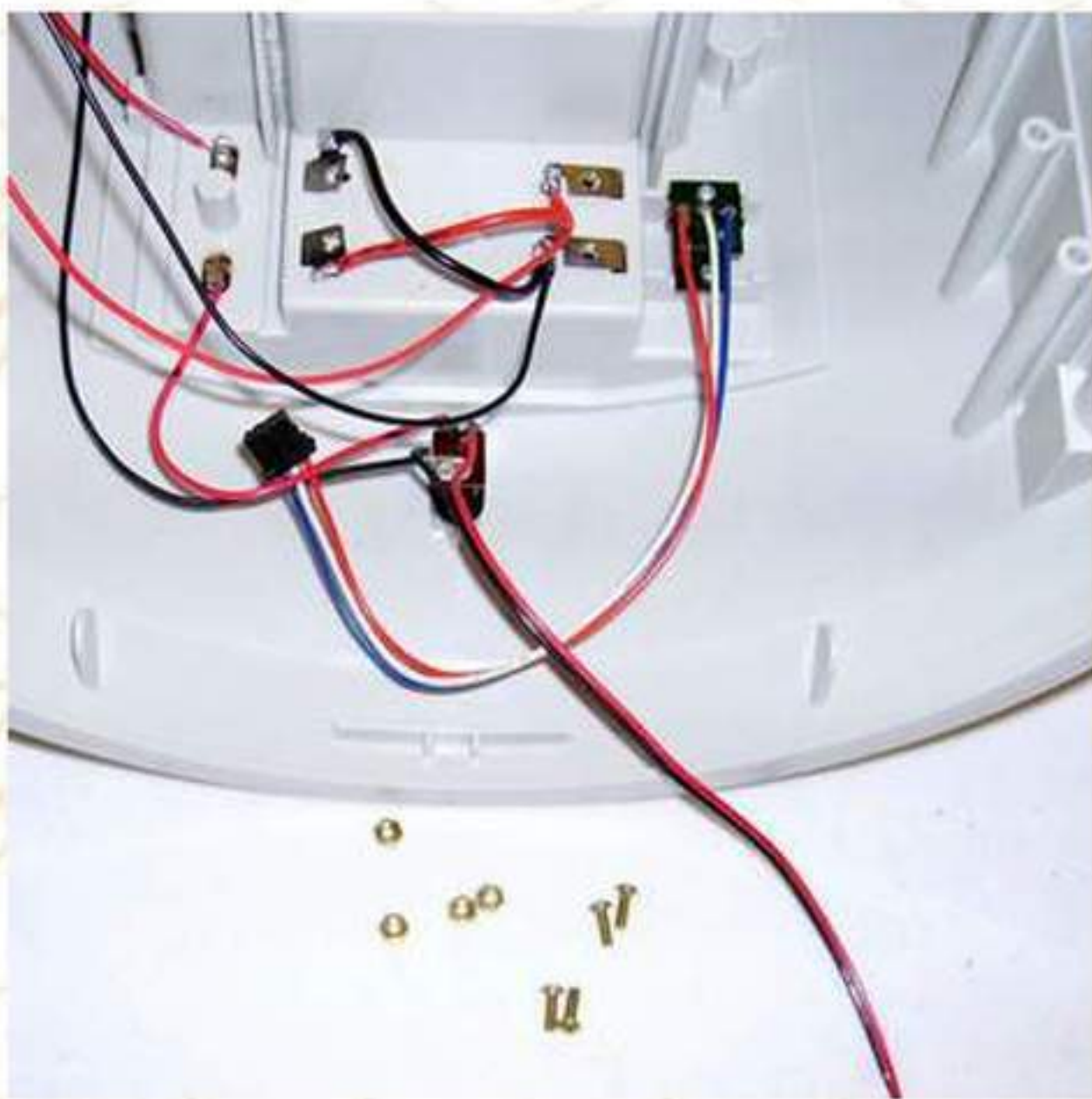

11. Use Brass 2/56 HEX MACH SC screws and nuts to fasten the battery contacts.

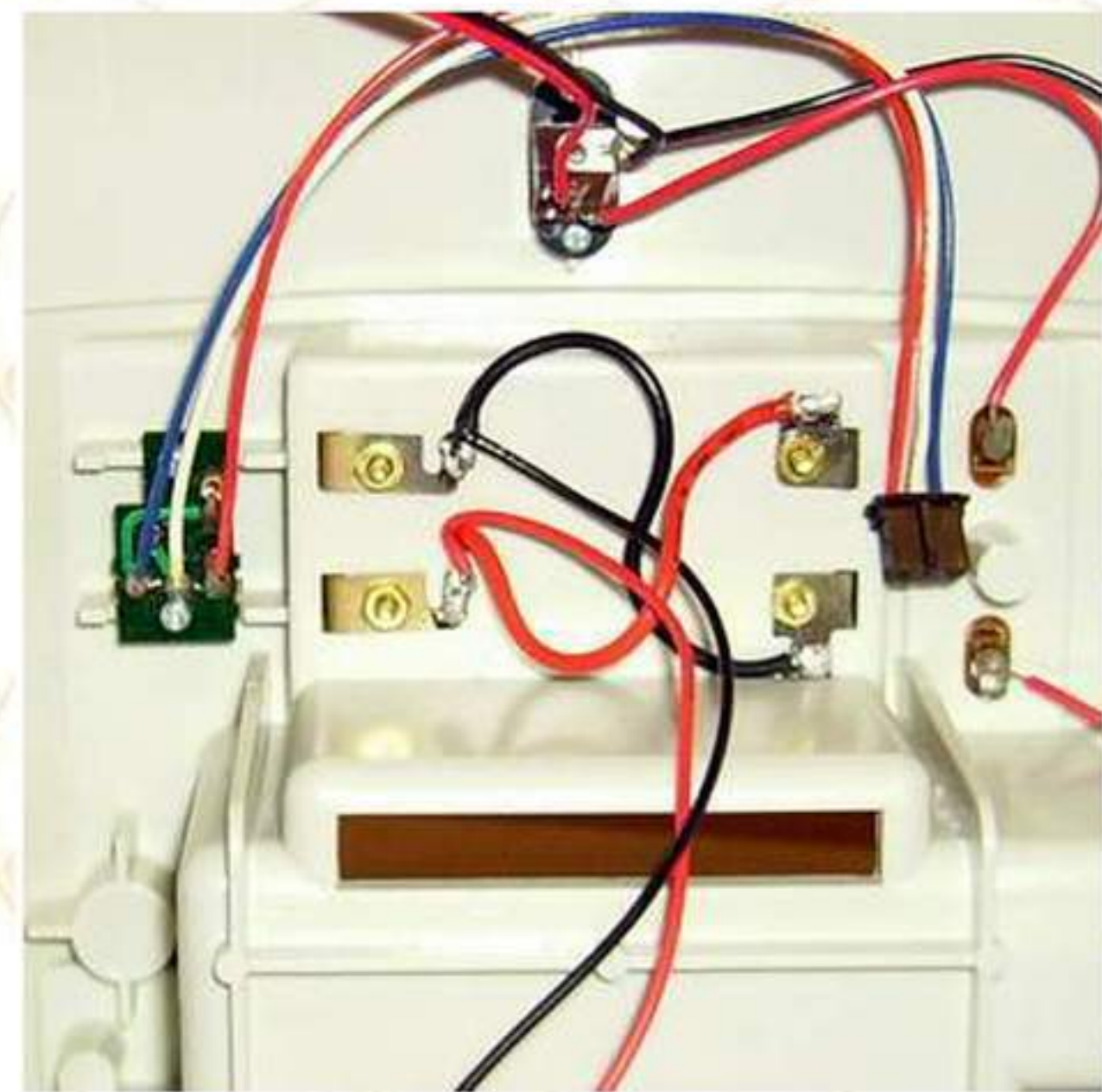

12. This is what the finished product will look like.



13. Use a multi-meter to check conductivity both at the rear and the plug. Temporary install batteries into the robot housing to check the installation.



14. This is what the finished product will look like.



15. Install batteries into the robot housing. The operation is finished.

The Omnibot Family Battery Contacts

The Omnibot[®], Omnibot 2000[®], Omnibot MK II[®], Hearoid[®] and the Robie Sr.[®] all have the same contacts, and can be replaced in the same manner. All of the clocks do not use two batteries and are not wired alike. Care should be taken to document the robot before using the replacement parts. The Robie Sr.[®] uses only one battery.



BEFORE



Shown above are some examples of contacts that are in the robots and controllers. This is one reason that they do not power up.

AFTER

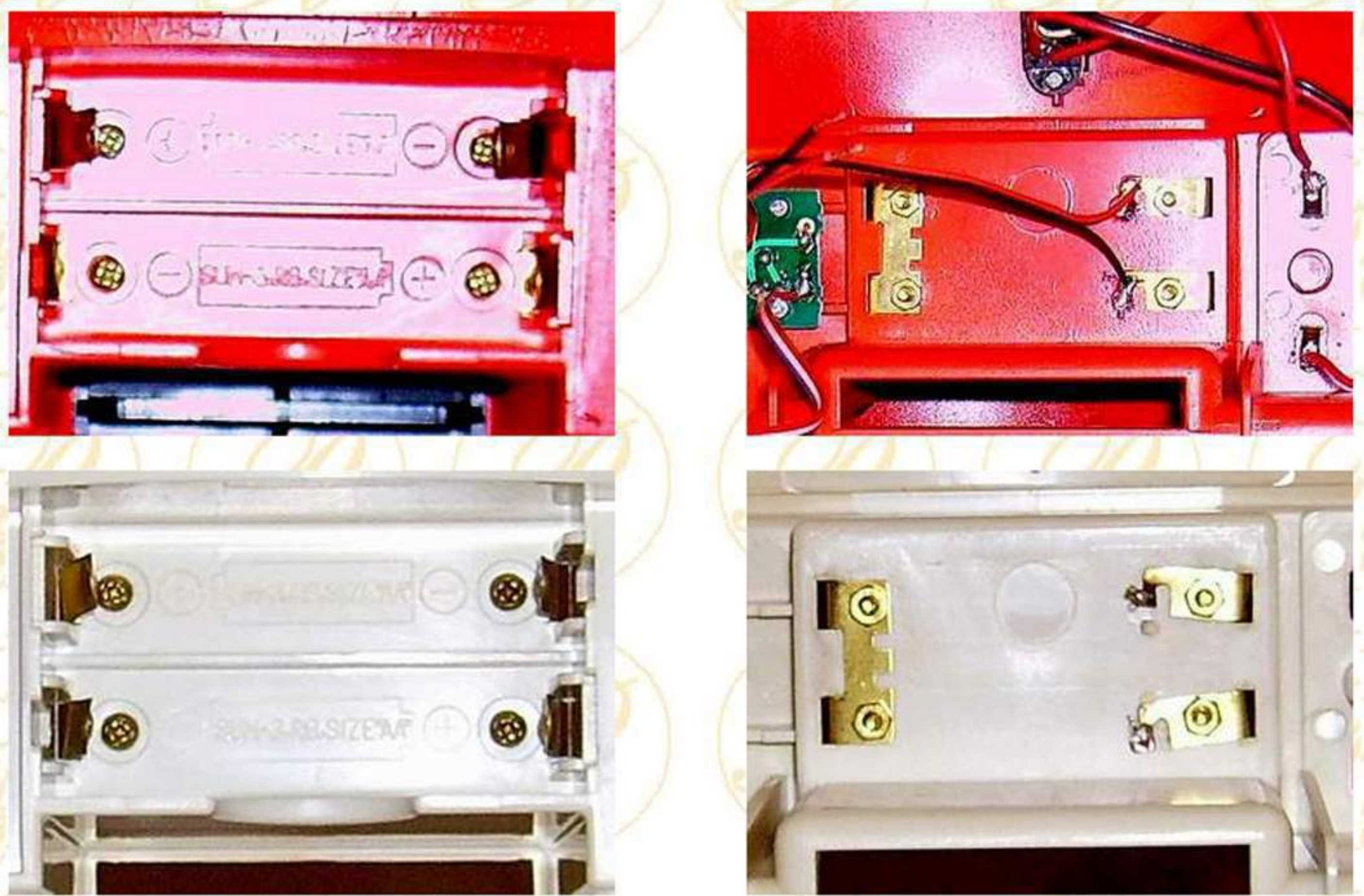

Shown above are some examples of contacts that have been replaced in the robots.

There is no warranty expressed or implied with this procedure. By using any information from this web site, you agree not to hold responsible this site, me, nor any of its representatives, for any injuries and/or damages, both physical and/or psychological, that may arise from the use and/or misuse of anything derived from this site. The user further agrees that such information/pictures does not constitute any guarantee of accuracy, safety or reliability, and that cannot be held responsible for any way. The user agrees to proceed at their own risk.



LEFT HAND

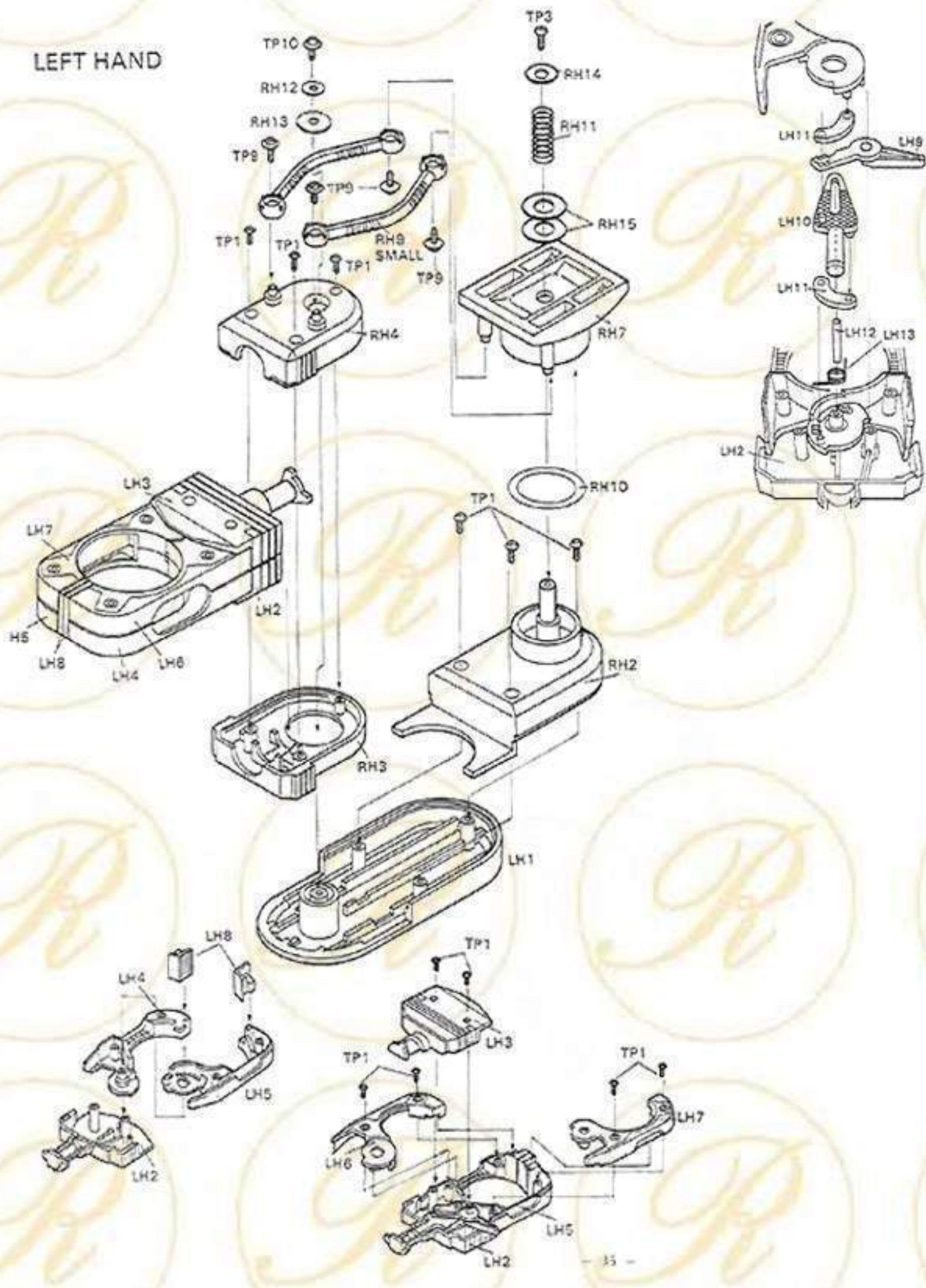

RIGHT HAND

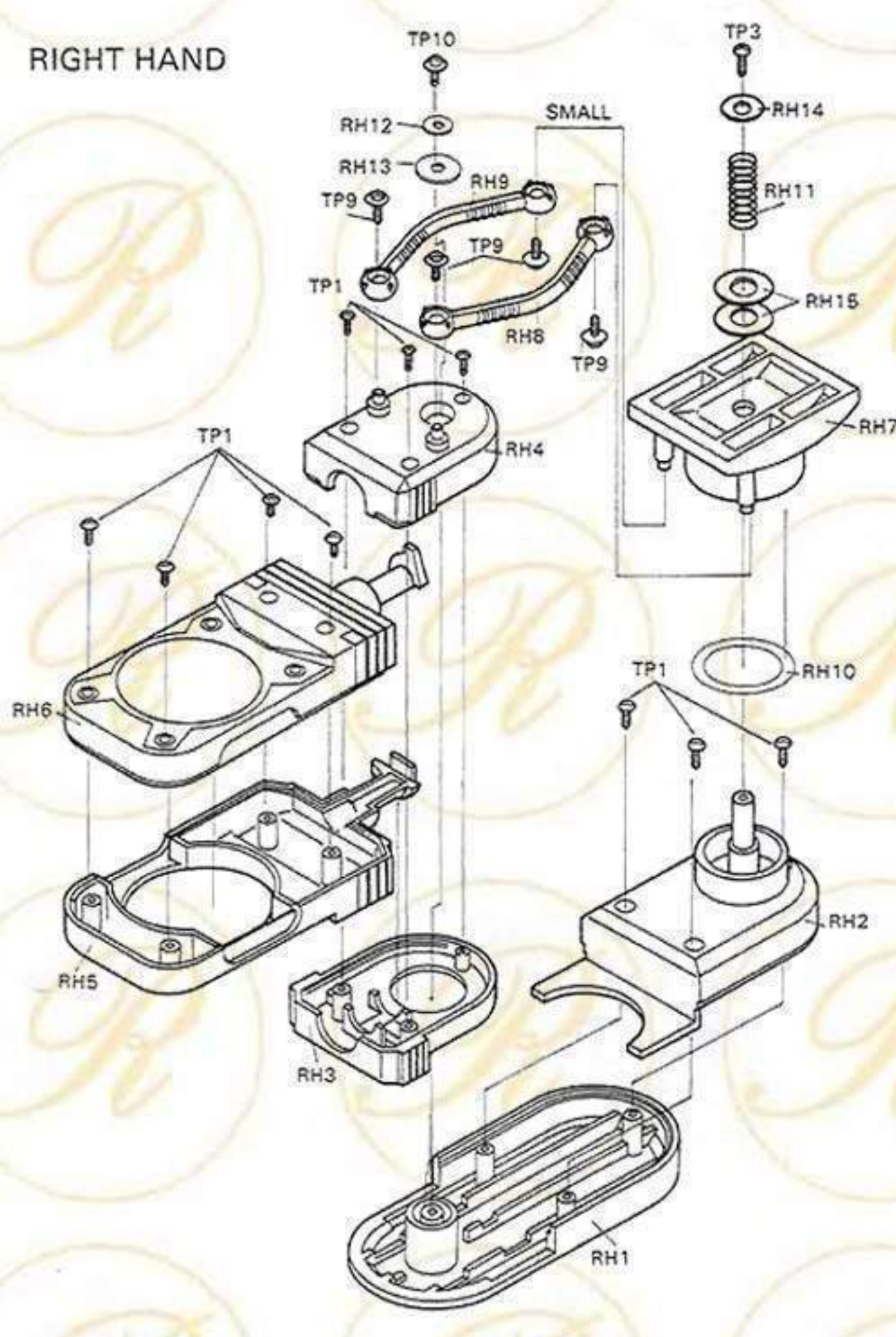

GEAR BOXES

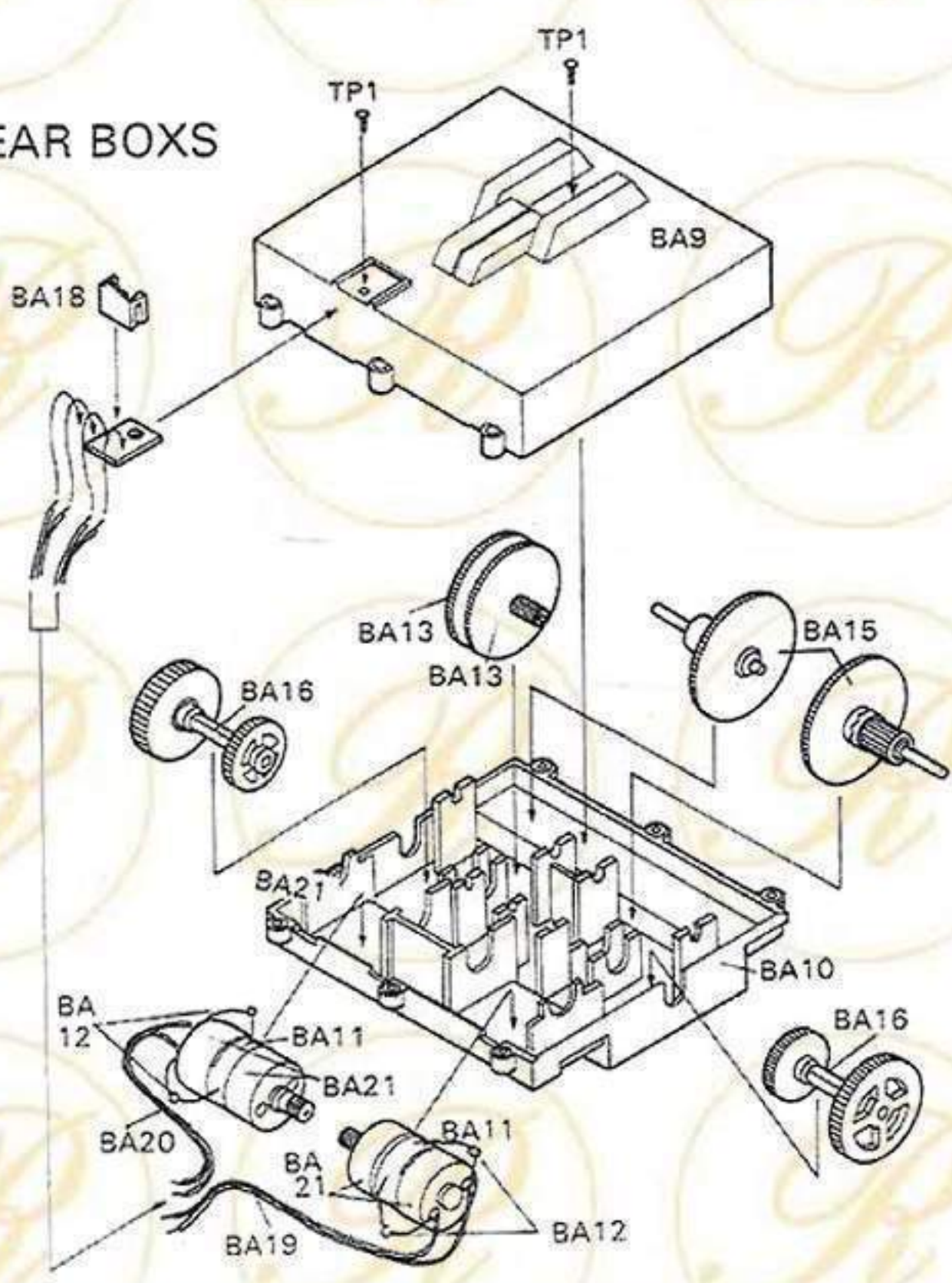

BASE

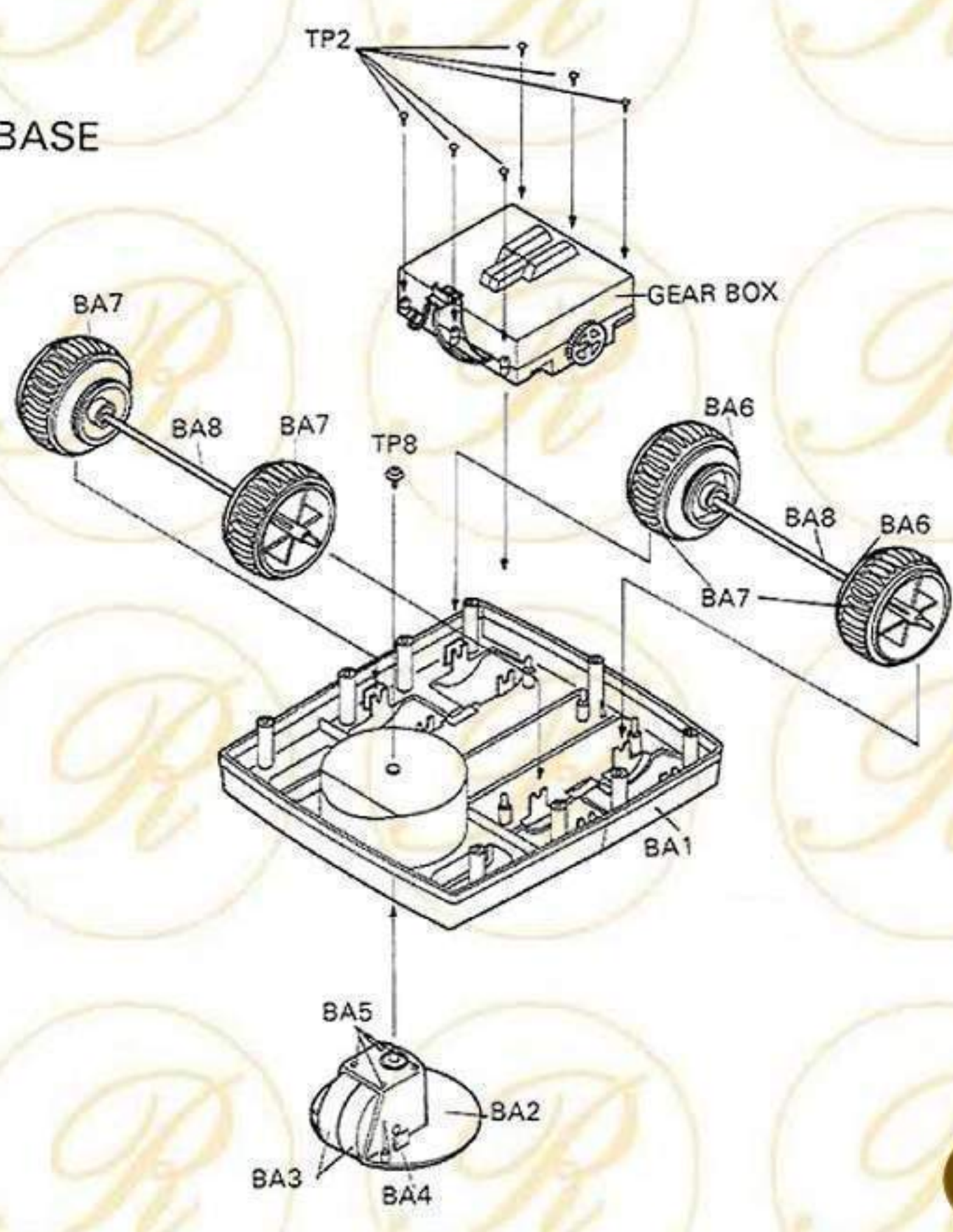

RECEIVER CIRCUIT

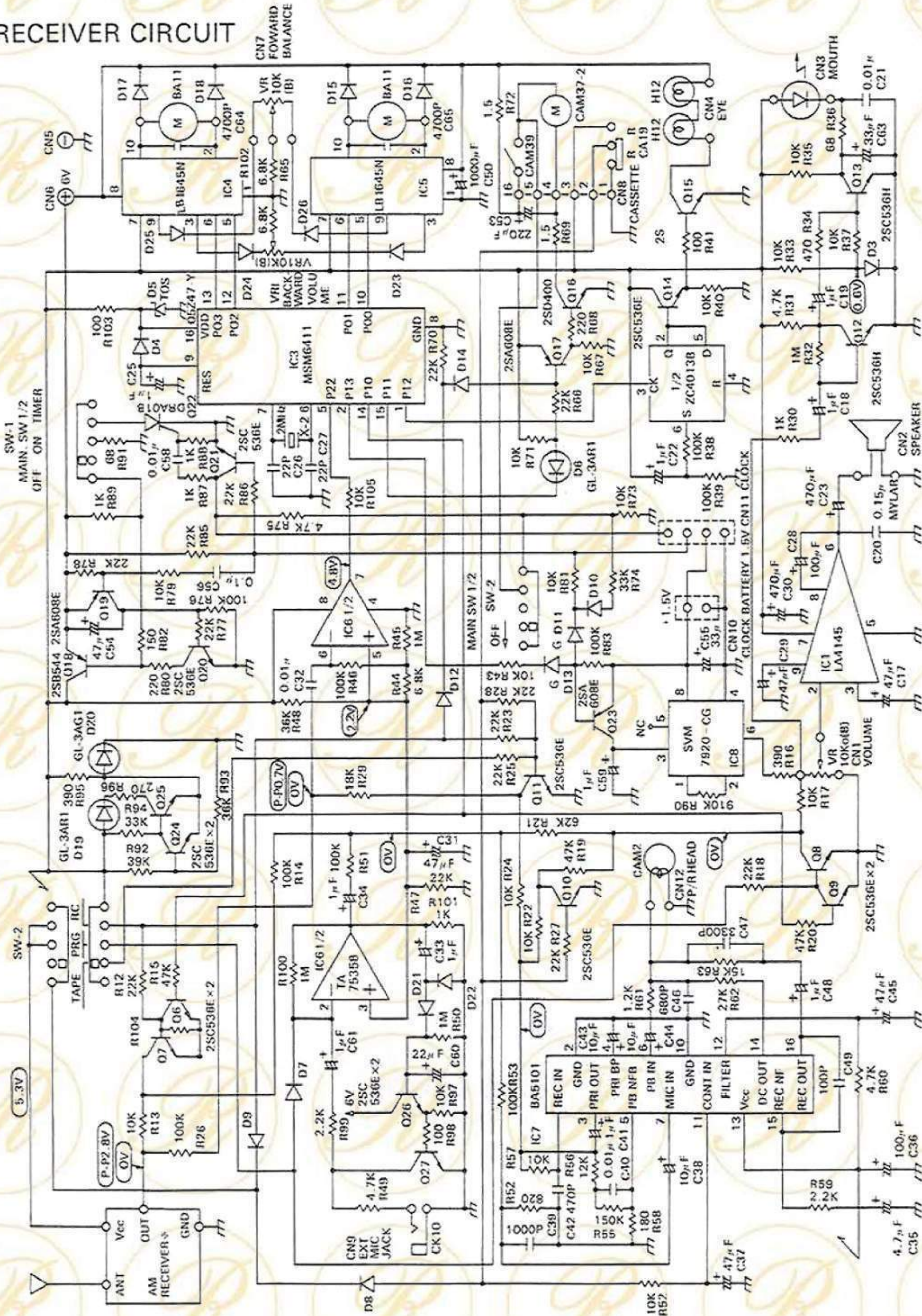



AM REMOTE CONTROL

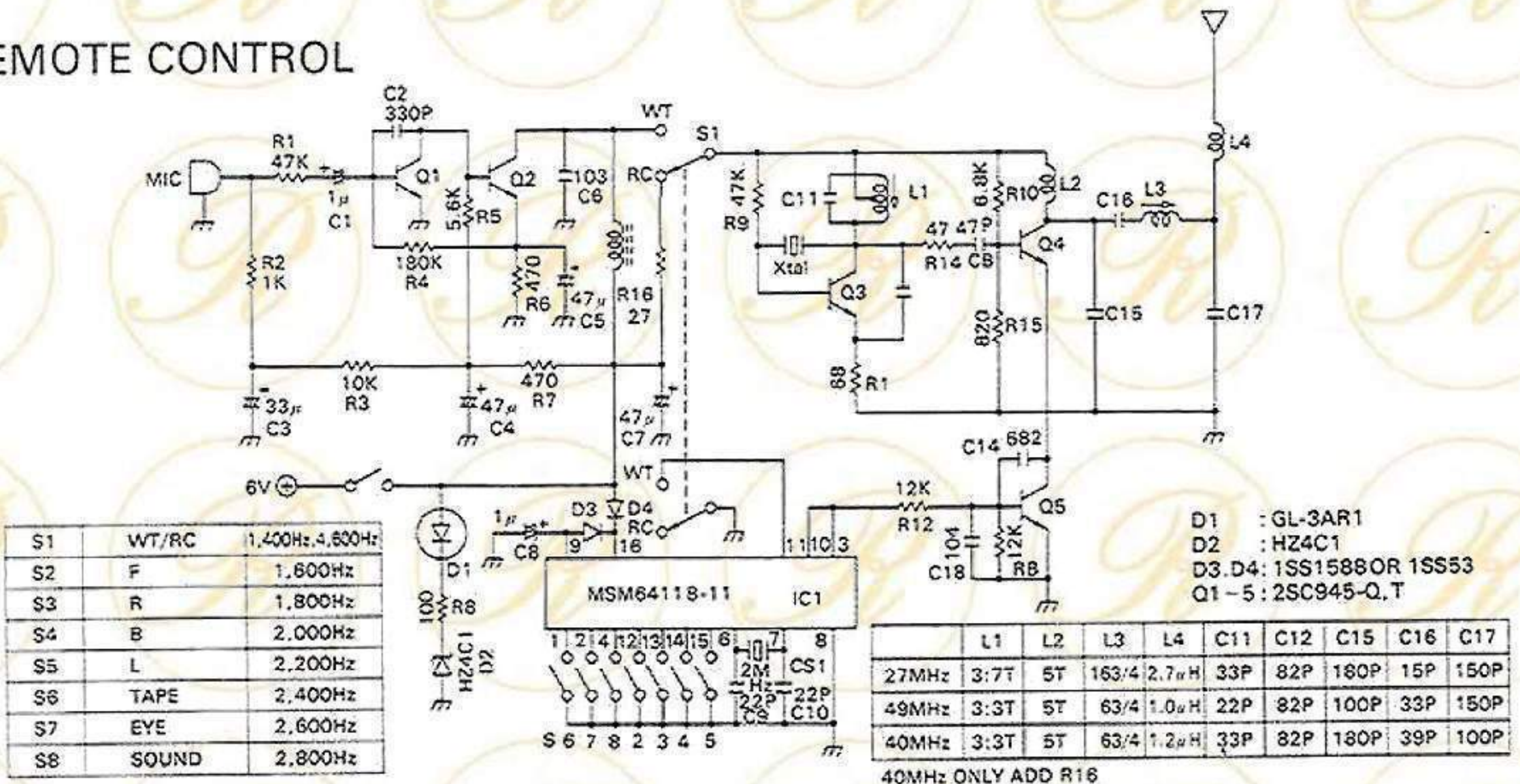

CLOCK

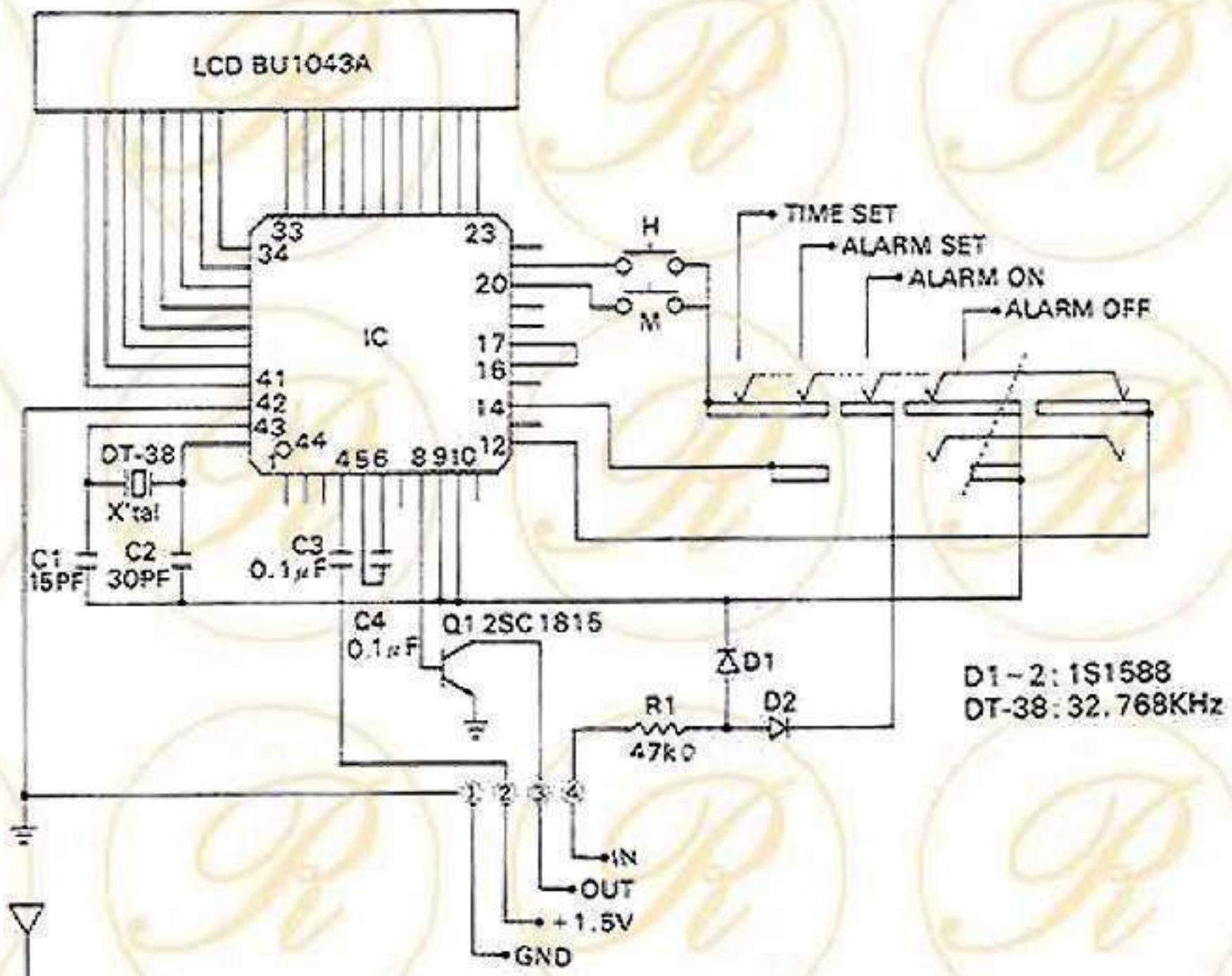

AM RECEIVER

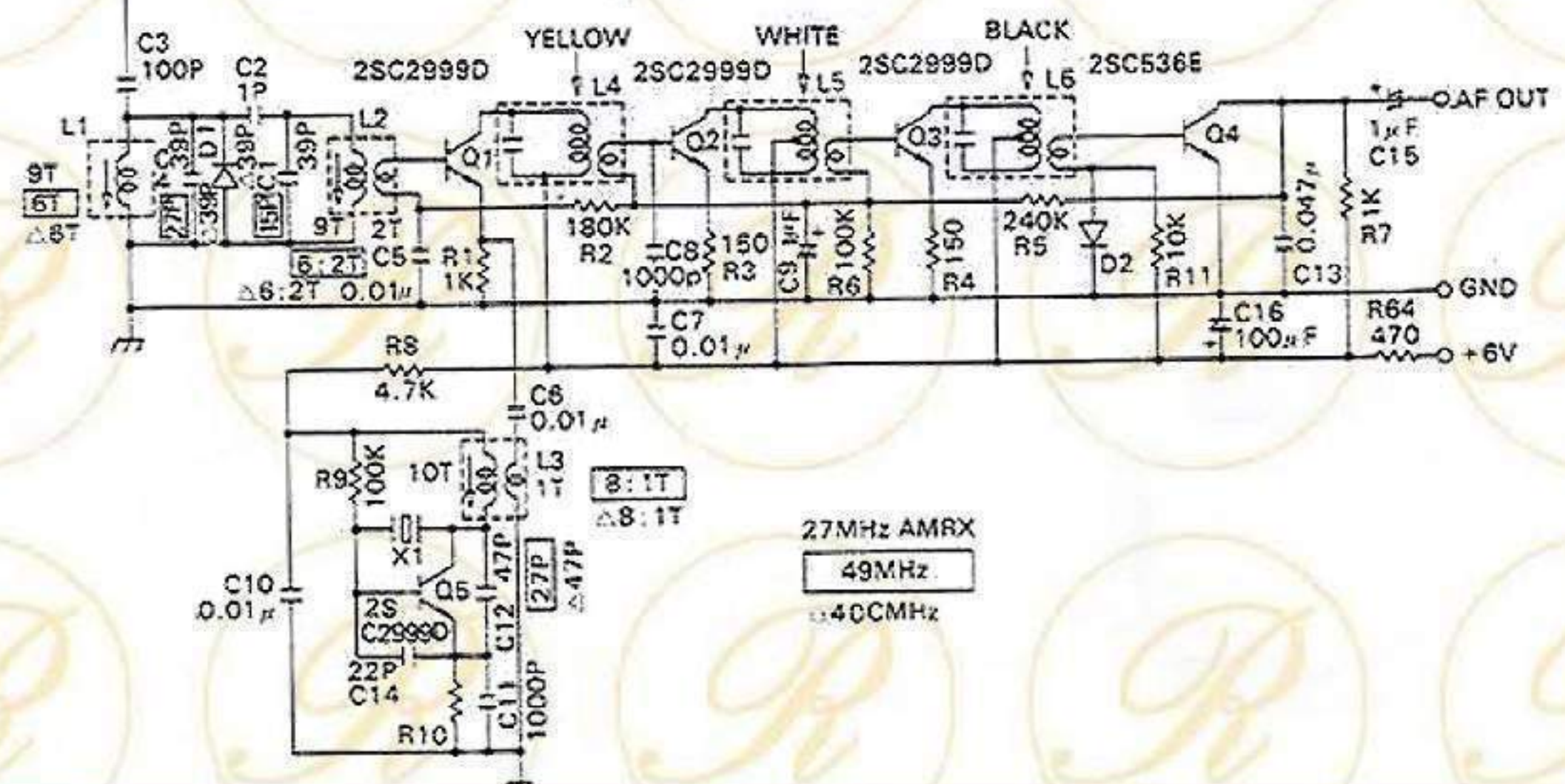



Omnibot 5402 Robot



Omnibot 5402 Robot



Omnibot 5402 Robot



Omnibot 5402 Robot



Omnibot 5402 Robot



Omnibot 5402 Robot



Omnibot 5402 Robot



Omnibot 5402 Robot





Omnibot 5402 Silver Robot



Omnibot 5402 Silver Robot



Omnibot 5402 Silver Robot



Omnibot 5402 Silver Robot



Omnibot 5402 Silver Robot



Omnibot 5402 Silver Robot



Omnibot MK-2 Robot



Omnibot MK-2 Robot



For a detail copy of manuals go to : <http://www.theoldrobots.com/>

Omnibot

Handbuch des Omnibot

1. Einleitung

2. Aufbau des Omnibot

3. Bedienung des Omnibot

4. Reparatur des Omnibot

5. Zubehör

6. Technische Zeichnungen

7. Garantie

8. Kontakt

9. Sonstiges

10. Anhang

11. Index

12. Glossar

13. Bibliographie

14. Literaturverzeichnis

15. Abbildungen

16. Tabellen

17. Formeln

18. Diagramme

19. Zeichnungen

20. Skizzen

21. Entwürfe

22. Modelle

23. Prototypen

24. Studien

25. Berichte

26. Dokumente

27. Briefe

28. Notizen

29. Protokolle

30. Berichte

31. Zusammenfassungen

32. Zusammenfassungen

33. Zusammenfassungen

34. Zusammenfassungen

35. Zusammenfassungen

36. Zusammenfassungen

37. Zusammenfassungen

38. Zusammenfassungen

39. Zusammenfassungen

40. Zusammenfassungen

41. Zusammenfassungen

42. Zusammenfassungen

43. Zusammenfassungen

44. Zusammenfassungen

45. Zusammenfassungen

46. Zusammenfassungen

47. Zusammenfassungen

48. Zusammenfassungen

49. Zusammenfassungen

50. Zusammenfassungen

51. Zusammenfassungen

52. Zusammenfassungen

53. Zusammenfassungen

54. Zusammenfassungen

55. Zusammenfassungen

56. Zusammenfassungen

57. Zusammenfassungen

58. Zusammenfassungen

59. Zusammenfassungen

60. Zusammenfassungen

61. Zusammenfassungen

62. Zusammenfassungen

63. Zusammenfassungen

64. Zusammenfassungen

65. Zusammenfassungen

66. Zusammenfassungen

67. Zusammenfassungen

68. Zusammenfassungen

69. Zusammenfassungen

70. Zusammenfassungen

71. Zusammenfassungen

72. Zusammenfassungen

73. Zusammenfassungen

74. Zusammenfassungen

75. Zusammenfassungen

76. Zusammenfassungen

77. Zusammenfassungen

78. Zusammenfassungen

79. Zusammenfassungen

80. Zusammenfassungen

81. Zusammenfassungen

82. Zusammenfassungen

83. Zusammenfassungen

84. Zusammenfassungen

85. Zusammenfassungen

86. Zusammenfassungen

87. Zusammenfassungen

88. Zusammenfassungen

89. Zusammenfassungen

90. Zusammenfassungen

91. Zusammenfassungen

92. Zusammenfassungen

93. Zusammenfassungen

94. Zusammenfassungen

95. Zusammenfassungen

96. Zusammenfassungen

97. Zusammenfassungen

98. Zusammenfassungen

99. Zusammenfassungen

100. Zusammenfassungen

Omnibot I5402 / TR5000 nstruction Manual - German (Version II)

United States Patent 4,654,659

U.S. Patent Jan. 27, 1987 Sheet 1 of 2 Des. 287,986

U.S. Patent Jan. 27, 1987 Sheet 2 of 2 Des. 287,986

Fig. 1

Fig. 2

Fig. 3

Fig. 4

Fig. 5

Fig. 6

Fig. 7

Omnibot Patents 4,654, 659



For a detail copy of manuals go to : <http://www.theoldrobots.com/>

Omnibot INSTRUCTION MANUAL

I. INTRODUCTION & FEATURES

II. BATTERIES & FUSE

III. CHARGING THE BATTERY

IV. TIME OF DAY

V. ALARM PROGRAMMING

VI. BASIC CASSETTE OPERATION

VII. MODES

VIII. MODE SELECTOR-TAPE

IX. MODE SELECTOR-A/C (REMOTE CONTROL)

X. STEERING ADJUSTMENT

XI. MODE SELECTOR-PROGRAM

XII. CASSETTE PROGRAMMING

XIII. SING-A-LONG

XIV. OMNIBOT'S ARMS AND TRAY

XV. HOME BASE

XVI. CARE & MAINTENANCE

XVII. SAFETY/CAUTIONS

XVIII. OMNIBOT- IDEAS AND USES

XIX. TROUBLESHOOTING

XX. TECHNICAL SPECIFICATIONS

XXI. MODE REVIEW

XXII. WARRANTY INFORMATION

IF YOU HAVE ANY QUESTIONS, HOME ENTERTAINMENT ROBOTS!

Omnibot 5402 / TR5000 Instruction Manual

Omnibot

多彩なおもしろいおもちゃ

このおもちゃの間に新登場

RADIO-CONTROL MODE

PROGRAM MODE

TAPE MODE

ギンギン

これなら遊べる、これなら使える。オムニボットは楽しきギンギン

Omnibot 5402 / TR5000



For a detail copy of manuals go to : <http://www.theoldrobots.com/>



Omnibot ® 5402/TR5000 By Tomy



Omnibot ® 5402/TR5000 By Tomy



Omnibot ® 5402/TR5000 By Tomy



Omnibot ® 5402/TR5000 By Tomy



For a detail copy of manuals go to : <http://www.theoldrobots.com/>

<p>ROBO LINK</p> <p>TOMY</p>	<p>1. INTRODUCTION</p> <p>The Robo Link robot is a unique... (text continues)</p>	<p>2. TABLE OF CONTENTS</p> <p>INDEX</p> <p>1 INTRODUCTION 2 INSTALLATION 3 BASIC OPERATION 4 EDITING YOUR PROGRAMS 5 SAVING YOUR PROGRAMS 6 DOWNLOADING 7 PRINTING 8 TRANSMISSION 9 FORWARD A PROGRAM 10 SPIN THE ROBOT 11 CALIBRATION 12 TROUBLE 130 HELPFUL HINTS 140 GETTING STARTED THE "QUICK WAY" FOR LANSBOT 150 GETTING STARTED THE "QUICK WAY" FOR LANSBOT</p>	<p>3. INTRODUCTION</p> <p>Robo Link is a computer software that allows you to program the Robo Link robot... (text continues)</p>	<p>4. INSTALLATION</p> <p>Before you can use the Robo Link software... (text continues)</p>	<p>5. BASIC OPERATION</p> <p>How to use the Robo Link software... (text continues)</p>	<p>6. EDITING YOUR PROGRAMS</p> <p>How to edit your programs... (text continues)</p>	<p>7. SAVING YOUR PROGRAMS</p> <p>How to save your programs... (text continues)</p>
<p>8. DOWNLOADING</p> <p>How to download programs... (text continues)</p>	<p>9. PRINTING</p> <p>How to print your programs... (text continues)</p>	<p>10. TRANSMISSION</p> <p>How to transmit programs... (text continues)</p>	<p>11. FORWARD A PROGRAM</p> <p>How to forward programs... (text continues)</p>	<p>12. SPIN THE ROBOT</p> <p>How to spin the robot... (text continues)</p>	<p>13. CALIBRATION</p> <p>How to calibrate the robot... (text continues)</p>	<p>14. TROUBLE</p> <p>Troubleshooting guide... (text continues)</p>	<p>130 HELPFUL HINTS</p> <p>Useful tips and tricks... (text continues)</p>
<p>140 GETTING STARTED THE "QUICK WAY" FOR LANSBOT</p> <p>Quick start guide for Lansbot... (text continues)</p>	<p>150 GETTING STARTED THE "QUICK WAY" FOR LANSBOT</p> <p>Quick start guide for Lansbot... (text continues)</p>	<p>160 LIMITED 90 DAY WARRANTY</p> <p>Warranty information... (text continues)</p>	<p>170 NOTICE</p> <p>Legal notice... (text continues)</p>	<p>180 COMPATIBLE HARDWARE</p> <p>Hardware requirements... (text continues)</p>	<p>190 CONTACT INFORMATION</p> <p>Contact details... (text continues)</p>	<p>200 INDEX</p> <p>Index of contents... (text continues)</p>	<p>210 HELPFUL HINTS</p> <p>Additional tips... (text continues)</p>

Tomy TM Robo Link TM by Computer Magic

Omnibot Deshooter Accessories

INFRARED SENSOR

ULTRASONIC SENSOR

TRACER TAPE

INSTRUCTIONS

PHOTO SENSOR

ULTRASONIC SENSOR

Omnibot MK II ® TR5500/TR5503 By Tomy ® Accessories Instruction

ACCESSORIES INSTRUCTIONS

ACCESSORIES

SECURITY DETECTOR

SECURITY DETECTOR

ACCESSORIES INSTRUCTIONS

Omnibot MK II ® TR5500/TR5503 By Tomy ® Accessories Instruction



ACKNOWLEDGEMENT AND APPRECIATION - I would like to extend Acknowledgement, Appreciation and Thanks, for Permission to use the Information and Pictures to, Friends, My Mentor, Individuals, The Hobbyist Collectors (World Wide), Robot Manufactures, Robot Collectables Stores, eBay Stores, Toy Museums, Web Sites, Book Authors and News Networks, that have helped me with recommendations, encouragement, support, information and pictures for the Users of this Book and Web Sites.

To Heath®, RB Robotics®, Androbot®, TTC®, Tomy® CBS Toys®, 2001 Trendmasters, Inc.®, Radio Shack®, Clone®, Ideal®, Hasbro®, and All Other Companies That Manufacture The Robots, or Companies That Claim Ownership, of pictures and information that are presented in this book or on this site. This book or site represents a presentation of my collection of robots and is for hobbyist only, and not for commercial use. It is not intended to represent your company or implied prior approval of anyone or any company, and any pictures or information that is in conflict with your company or policies, will be revised or removed when requested. I would like you to consider that the pictures and information are of both a collector and historical interest to many people. Many times when such a collector comes into ownership of one of these robots it is incomplete, they rarely obtain all of the information and material that comes with it. Without this information, they have an incomplete item.

All images, names, information, quotes or sounds used are the property of respective owners. Copyright and trademarks have been acknowledged where possible. No affiliation or endorsement has been made or taken, unless clearly indicated. Infringement is not intended. Contents will be removed if in violation. All material posted is for identification, entertainment, information, demonstration purposes and historical documentation only.

RB Robotics® Still produces the RB5X®.

Androbot® Produced the Topo®, Fred® and BOB® robots Educational and Personal Robots.

CBS Toys Produced for IDEAL™ the Electronic Maxx Steele™ Personal Robot

All Other © Companies That Manufacture The Robots, or © Companies That Claim Ownership

Heathkit® Produced the Hero®, Hero Jr®, Hero 2000® and the Hero Arm Trainer®. Formerly from Heathkit, then Mobile Ed Productions, Now Proudly brought to you by the Robot Workshop!

Tomy Co Ltd. produced the Omnibot line of robots from 1982 up until 1988 TOMY Co., Ltd. - In Japanese, K.K. Takara-Tomy Founded March 1, 2006 . Headquarters HQs in Japan, United States, United Kingdom, France, Hong Kong, Thailand. TOMY Co., Ltd. is the legal English name for the Japanese toy, children merchandise and Entertainment Company created on March 1, 2006 by the merger of "former" Tomy (Founded 1924) with Takara Co. Ltd. (Founded 1955). However, the new company made the unusual decision to adopt two different legal corporate names so while in English the name is simply TOMY, in Japanese the legal company name is the combined name, K.K. Takara-Tomy.

Radio Shack produced not limited to, but; include: Robie® Sr, Robie® Jr, Robie® The Talking Robot, Mobile Armatron®, Armatron®, Super Armatron®, and the Z-707 Iron Claw®

Axlon produced robots from 1984 up until 1986/7 Axlon produced a number of robots that include: Compurobot / George , Dogbot , Spybot , Talkabot. Compurobot was marketed as George in the UK by CGL but was Axlon design. The Axlon Company was founded by Nolan Bushnell (creator of Atari, Androbot Inc.) in 1984. Axlon was largely sold to Hasbro.

The pictures used are originals taken, manufactured or created from my robots, composite of pictures made by me, the manuals, instruction sheets, pictures or information sent to me, Advertisement and letters saved from the 1980,s, Magazines no longer printed, and pictures from the internet from other hobbyists.

The information contained in this book or on the site is not to be used for profit but you can copy it for personal use. You cannot claim ownership, restrict, or cause to be restricted, or change the status of any files that you download from this site. You cannot use the files for commercial use such as selling, advertising or monetary transactions. These files and pictures are free, you may use them, give them away, you cannot claim ownership restrict or sell them. When used, you must acknowledge from where the files originated.



Omnitrix

Companion