

Maximum Power. Ultimate Control.



OPERATIONS MANUAL

INCLUDES
DEFENDERS OF
THE HIGHTOWER
COMIC
BOOK



I REMEMBER
THIS STAR
SYSTEM.

I WAS HERE
EONS AGO TO
PLANT THE SEEDS
OF SURVIVAL.

A PITY THAT ALONE
CAN NO LONGER
HELP THESE POOR,
SIMPLE PEOPLE.

NO... THE ZYTONS
HAVE FINALLY
LEARNED A WAY TO
OVERCOME MY
ROBOTIC DEFENSES.

SOON, THE ZYTONS
WILL ARRIVE...

SOON, THIS
PEACEFUL WORLD
WILL BE NO MORE.

MY MIND
CAN WANDER THE
SPACEWAYS, BUT MY
BODY IS WEAK. ONCE,
I COULD CHALLENGE
THE ZYTON MENACE...
BUT THOSE DAYS
ARE GONE.

NOW, I CAN
ONLY WATCH...
AND HOPE.

HOPE... FOR A SINGLE
HUMAN SPIRIT TO
RISE UP AND MEET THE
COMING CHALLENGE...

HOPE... FOR A MIND WITH
THE POWER TO MASTER THE
TECH FORCE WEAPONRY
I HAVE PLACED ACROSS
THE GALAXY TO PROTECT
INNOCENT LIVES...

HOPE... FOR THE--

DEFENDER OF THE HIGHTOWER

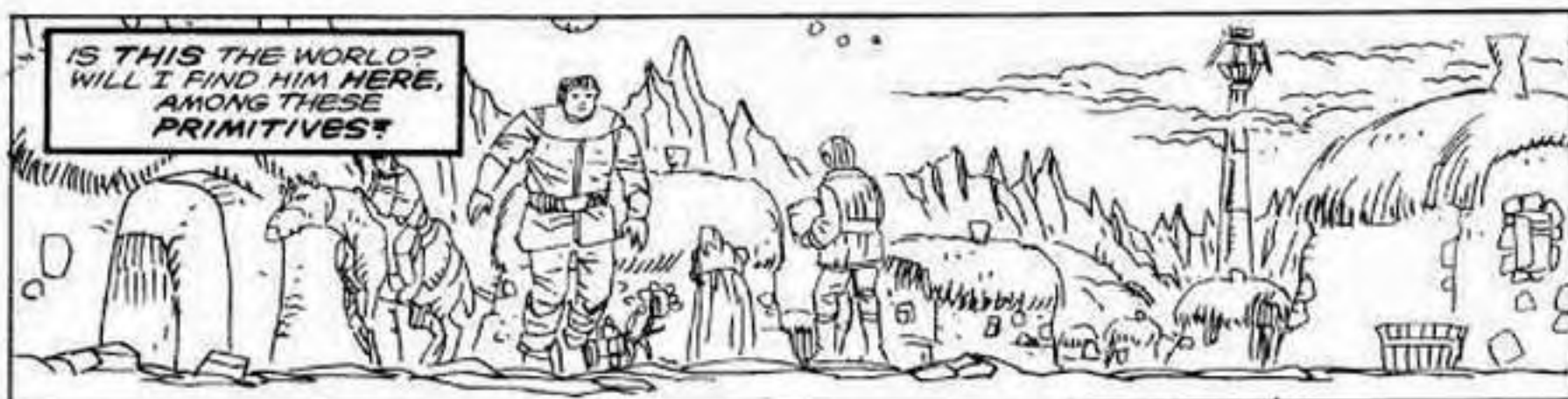

IS THIS THE WORLD?
WILL I FIND HIM HERE,
AMONG THESE
PRIMITIVES?



AHH... A PLACE OF
LEARNING... A SCHOOL,
PERHAPS ONE OF THE
STUDENTS...?

I SHALL WAIT...
AND HOPE.



-- SO YOU SEE, CLASS,
OUR WORLD SPINS LIKE
A TOP, AND THAT KEEPS
THE OUTER REGIONS
FROM CAVING IN
ON US!



IT'S SIMPLE, REALLY!
BEYOND THE MOUNTAINS,
THERE IS *NOTHING*. THE
PLANET TAPERS OFF FROM
THERE, AND THEN--

NO! THAT--
THAT
CAN'T BE!



THERE *HAS* TO BE
SOMETHING *MORE* OUT
THERE! THERE'S SO
MANY STARS! SO
MANY *SUNS*!

AND WHAT
ABOUT THE
HIGHTOWER?
NO ONE--



STOP, ALEX-7! I
WILL HEAR *NO MORE*
FROM YOU! I AM THE
TEACHER! YOU ARE
THE *STUDENT*! IF
YOU CONTINUE
WITH THESE--

AHEM...
FIELD TIME,
STUDENTS
PICK UP YOUR
THINGS
NOW...

BONG
BONG
BONG

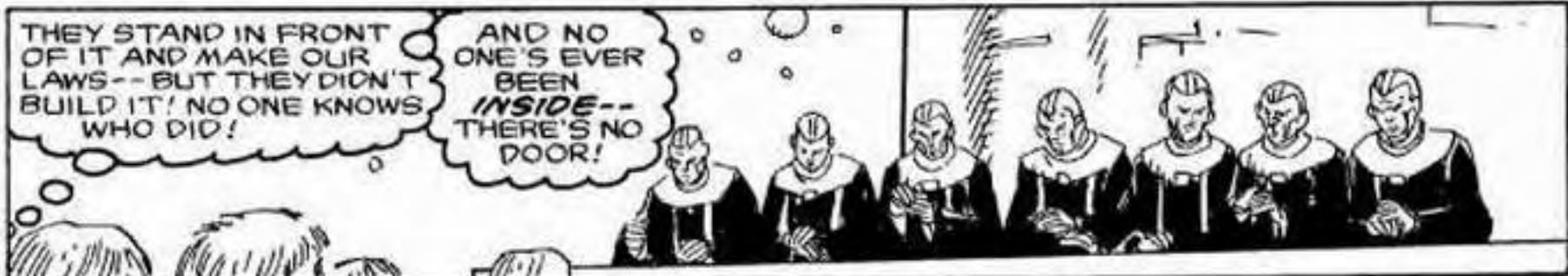



WELL, ALEX-7, IF THERE ISN'T EMPTY SPACE BEYOND THE MOUNTAINS, THEN WHAT IS?

I'M NOT SURE...



... BUT MAYBE THERE'S OTHER GROUPS OF PEOPLE JUST LIKE US! MAYBE THEY THINK THE SAME WAY WE DO!

MAYBE THEY'RE JUST AS AFRAID TO EXPLORE THE WORLD AROUND THEM AS WE ARE!

THERE'S ONLY ONE WAY TO FIND OUT--



THAT'S IT, ALEX-7! YOU'RE FINISHED!!



AND SO...

... AND BECAUSE ALEX-7'S **TEACHER** SAYS THE CHILD IS A **BAD INFLUENCE** ON THE OTHER STUDENTS, I HEREBY **ORDER** HIM TO REMAIN IN HIS HOME UNTIL FURTHER NOTICE!



LATE THAT NIGHT...

THEY JUST DON'T UNDERSTAND... BUT ONE DAY...



SHOOOONNNNN!

WHA--?!



IT'S HAPPENING! THEY'RE HERE!!

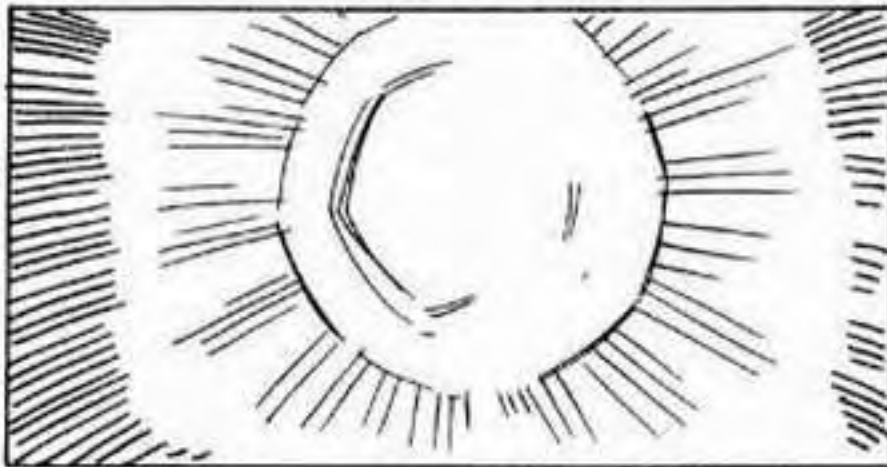
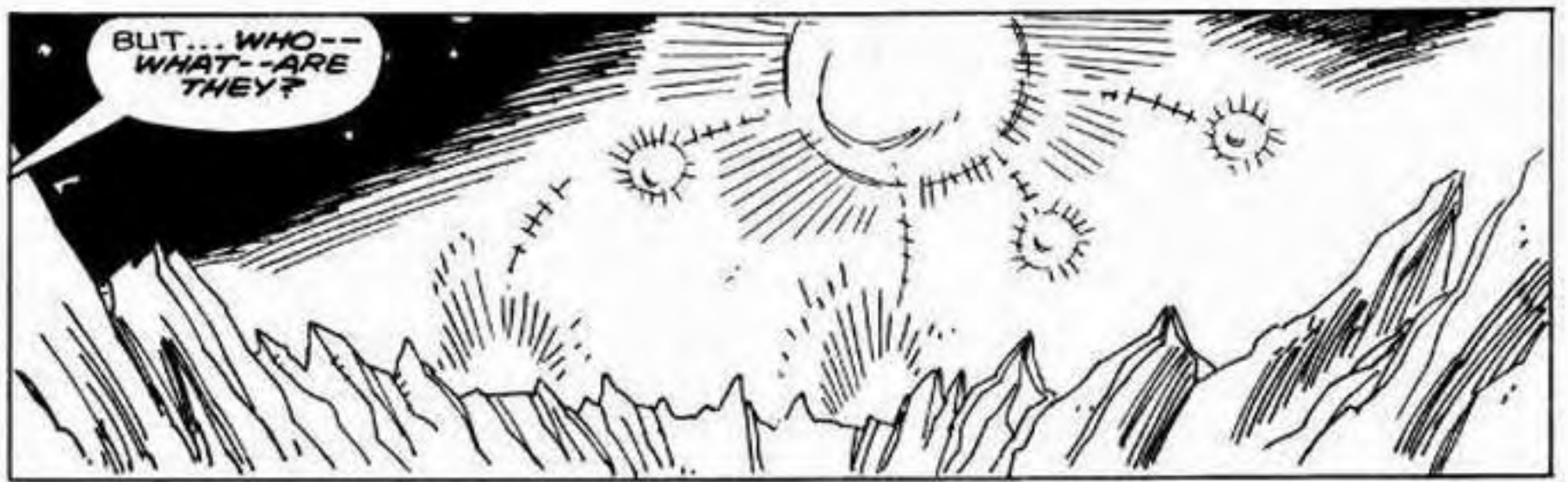

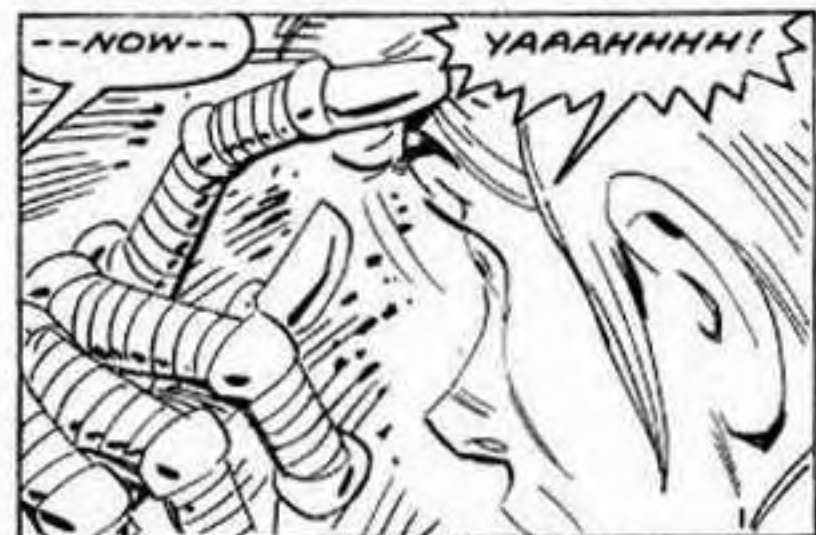



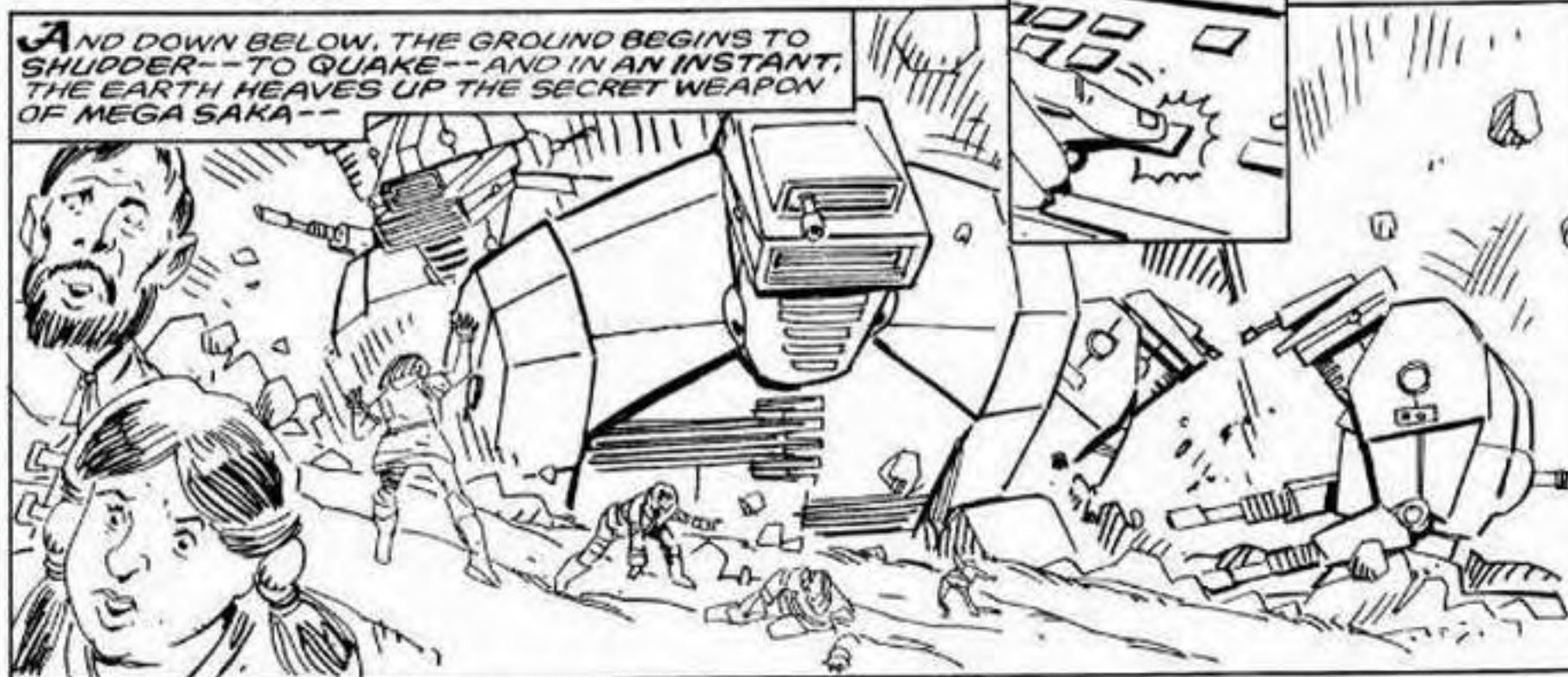
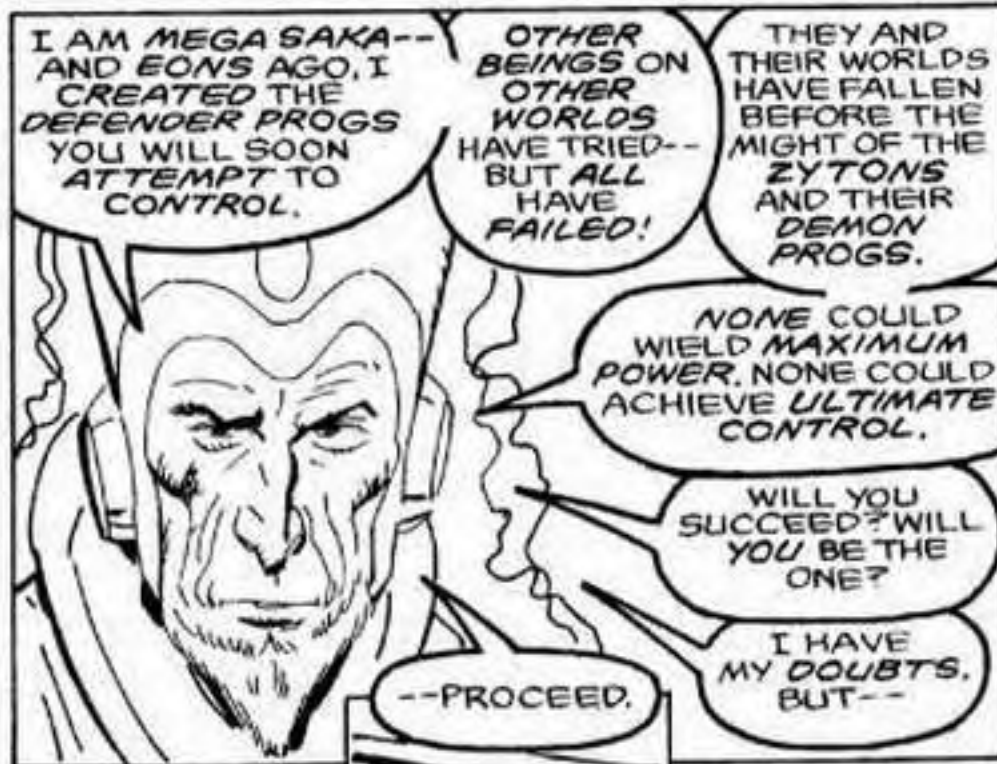

THIS IS AMAZING!
I CONTROL THEIR
EVERY MOVE! I CAN
USE THEM TO
DESTROY THOSE
DEMON PROGS--
AND SAVE MY
PEOPLE!



THIS CONSOLE--
IT IS MAXIMUM
POWER! IT DOES
GIVE ME
ULTIMATE
CONTROL-- BUT I
CAN HANDLE IT!!



"BEWARE THE INVAZER
BEAMS, ALEX-7! THEY
AFFORD GREAT FIRE-
POWER--"

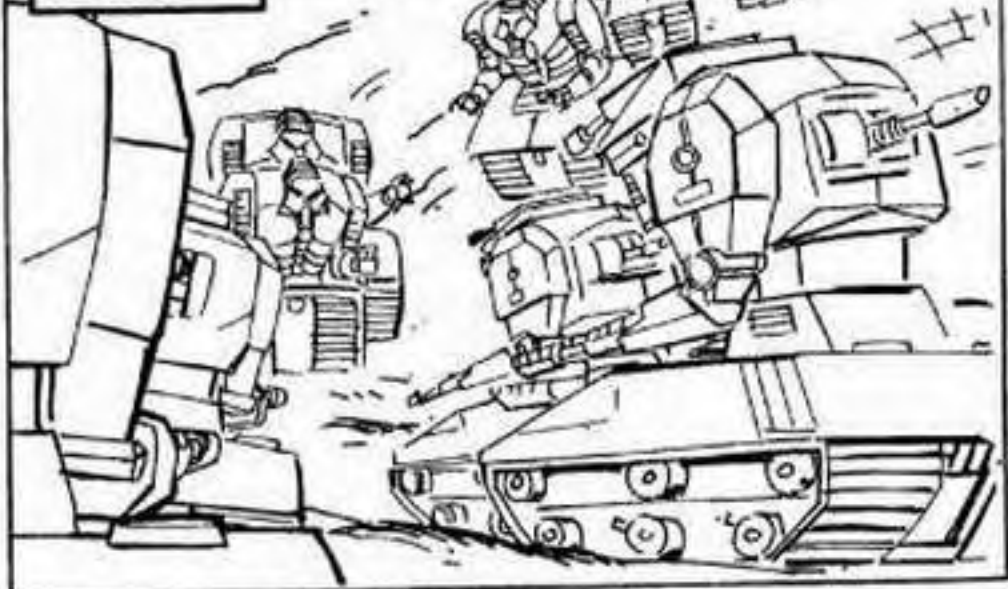

"--BUT YOUR DEFENDER
PROGS CAN BE
IMMOBILIZED BY THEM,
TOO!"



HEY! IT'S NOT RESPONDING
TO MY COMMANDS!

THE EFFECT
OF THE
INVAZER
BEAMS IS
ONLY
TEMPORARY.
THE
DEFENDER
PROG'S
POWER WILL
SOON
RETURN.

BUT IF
YOU CAN
IMMOBILIZE
THEM ALL,
VICTORY WILL
BE YOURS!

USE THAT
KNOWLEDGE
TO YOUR
ADVANTAGE!



"USE YOUR SKILL TO
ATTACK THE DEMON
PROGS WHILE THEIR
ATTENTIONS ARE
DIVERTED--"

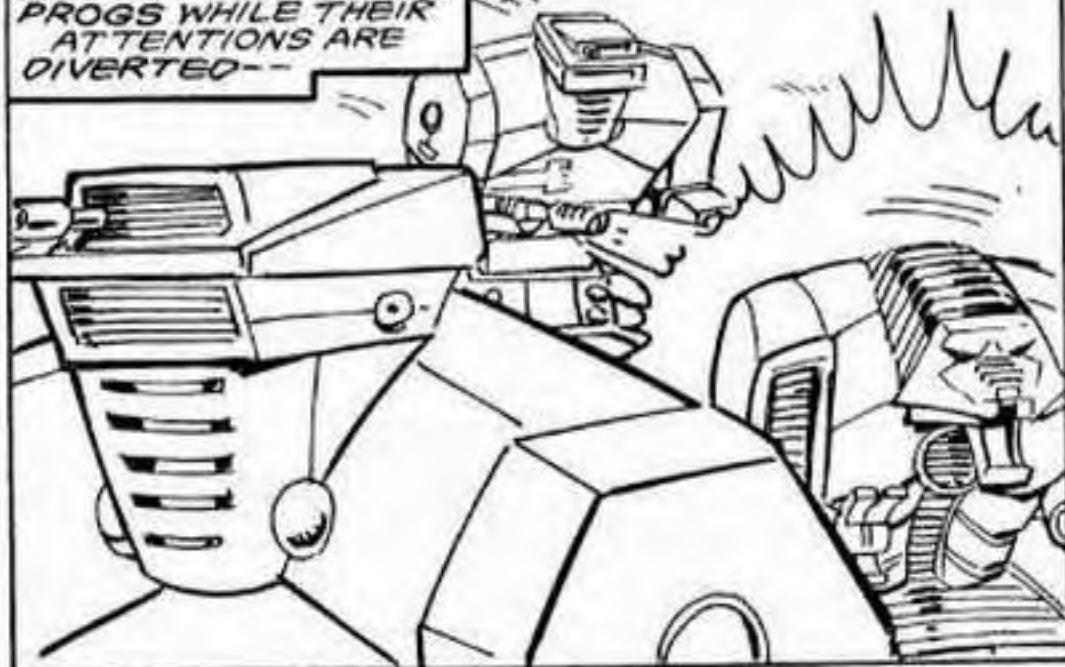

"USE YOUR CUNNING
TO PRESS YOUR
ADVANTAGE!"

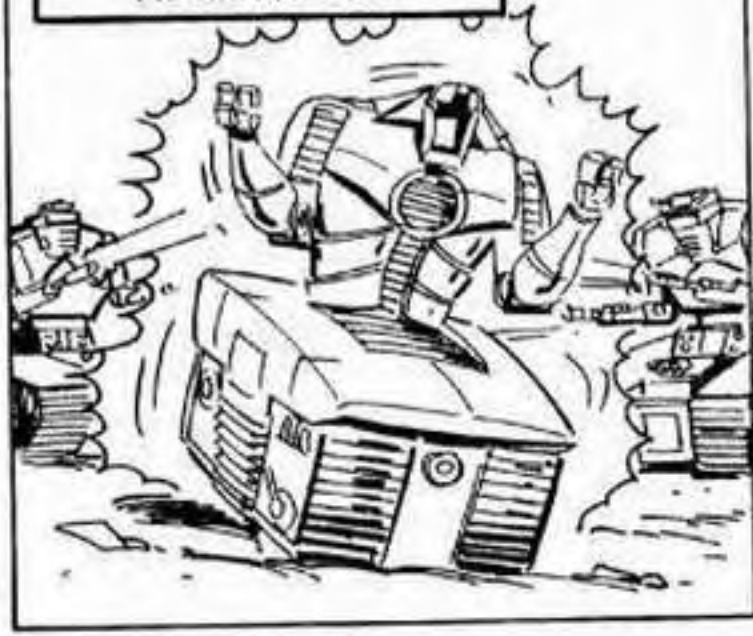



HEY! THIS IS EASY! IN A COUPLE OF MINUTES, THIS LITTLE WAR WILL BE OVER!

YOU PRESUME TOO MUCH, ALEX-7. THE BATTLE HAS JUST BEGUN!

FOR YOUR NEXT CHALLENGE-- LOOK TO THE SKIES!



"THE ZYTON MOTHERSHIP HAS MANY SURPRISES WITHIN ITS STEEL WALLS--"

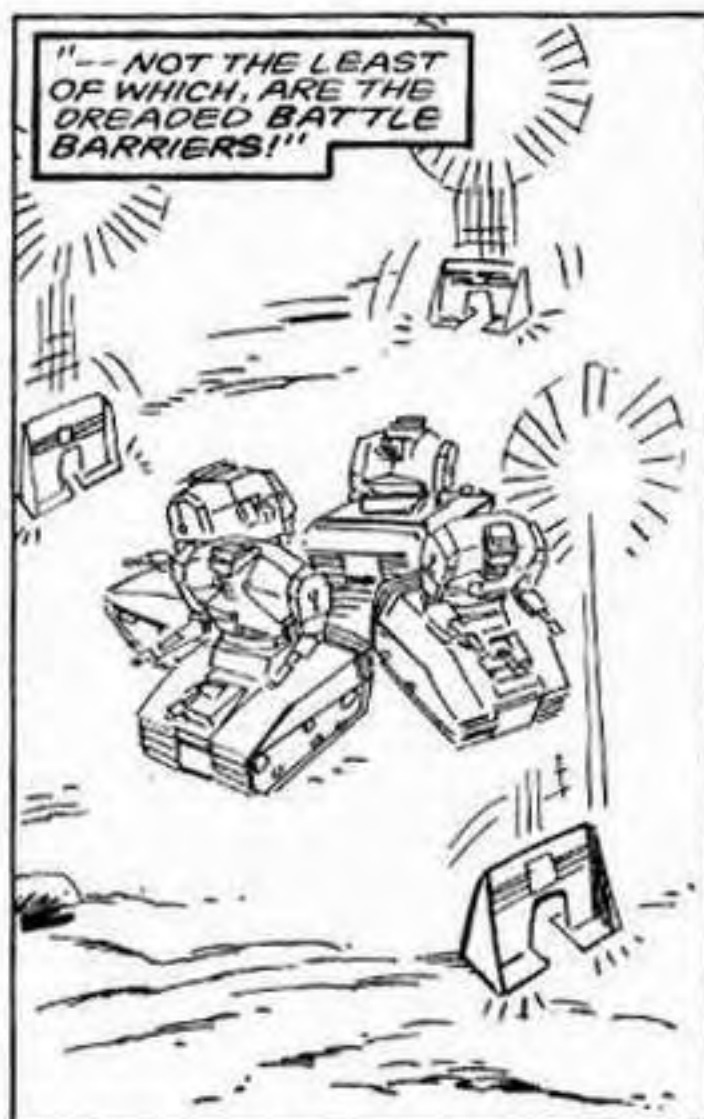

"-- NOT THE LEAST OF WHICH, ARE THE DREADED BATTLE BARRIERS!"



THE COMPUTER COMMAND CONSOLE-- IT'S NOT RESPONDING AT ALL!

CORRECT, ALEX-7. THE BATTLE BARRIERS SCRAMBLE ALL REMOTE COMPUTER FREQUENCIES WITHIN THEIR VIBRATION MATRIX.

WHAT ARE YOU TALKING ABOUT??!

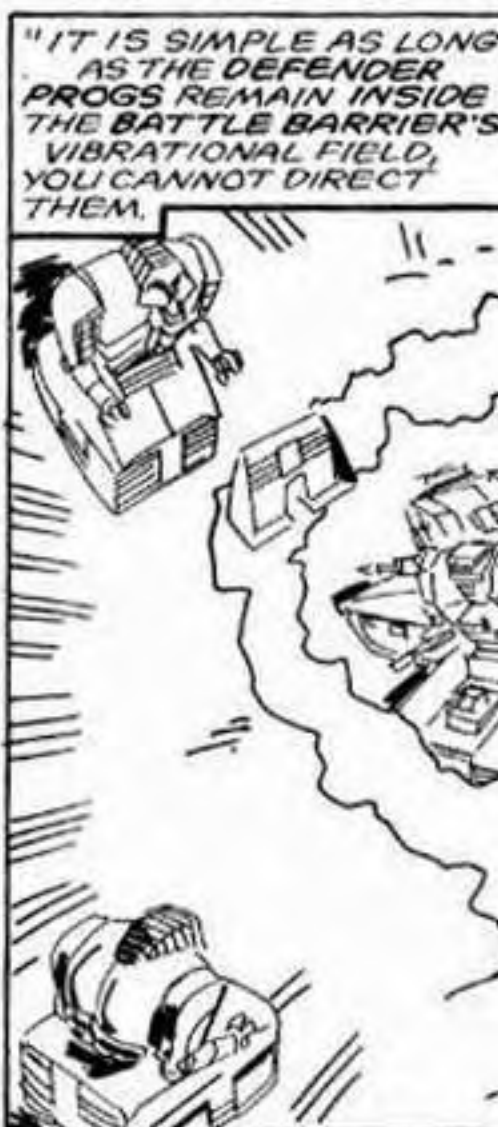

"IT IS SIMPLE AS LONG AS THE DEFENDER PROGS REMAIN INSIDE THE BATTLE BARRIER'S VIBRATIONAL FIELD, YOU CANNOT DIRECT THEM."

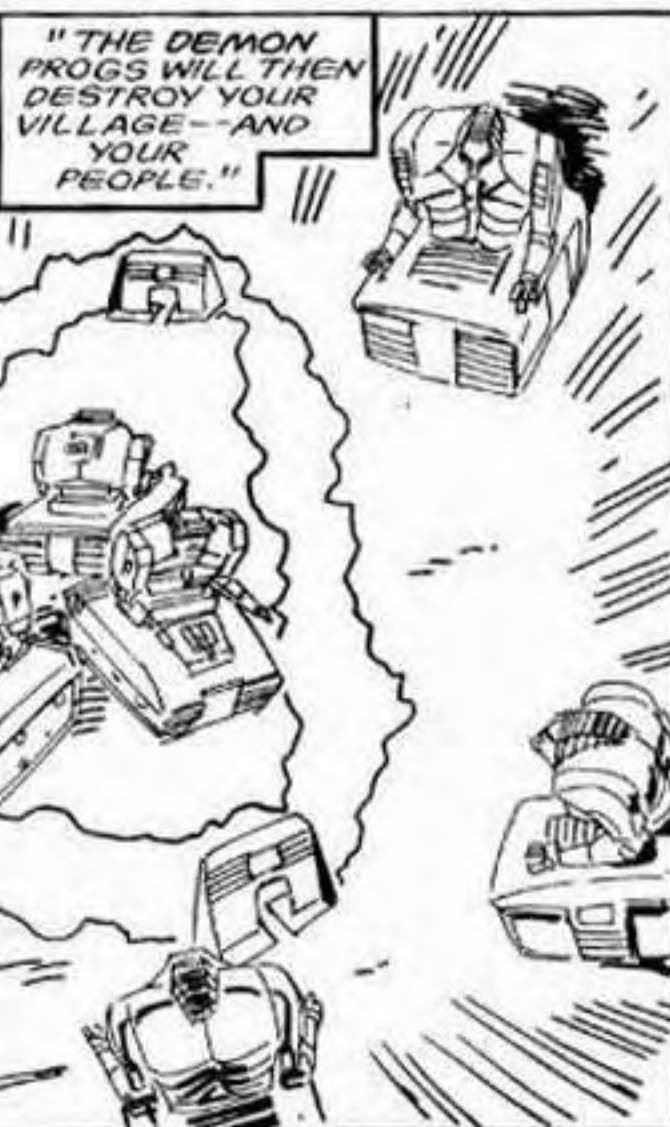

"THE DEMON PROGS WILL THEN DESTROY YOUR VILLAGE-- AND YOUR PEOPLE."

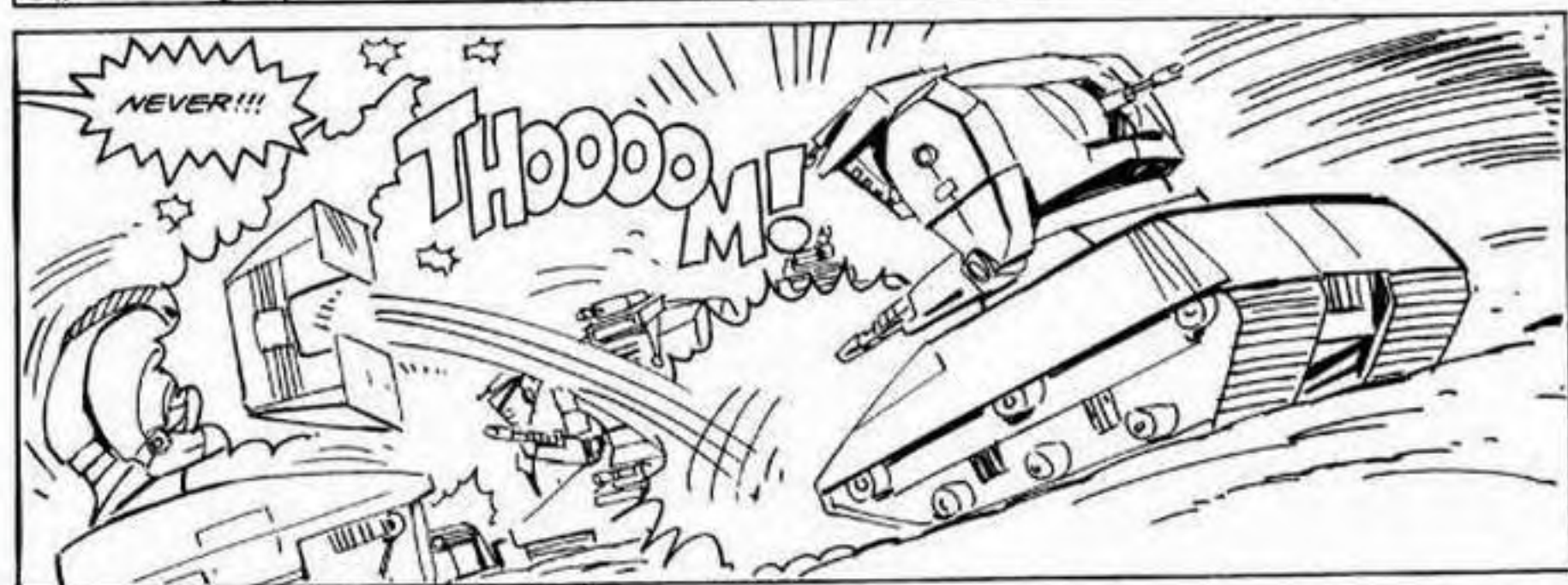
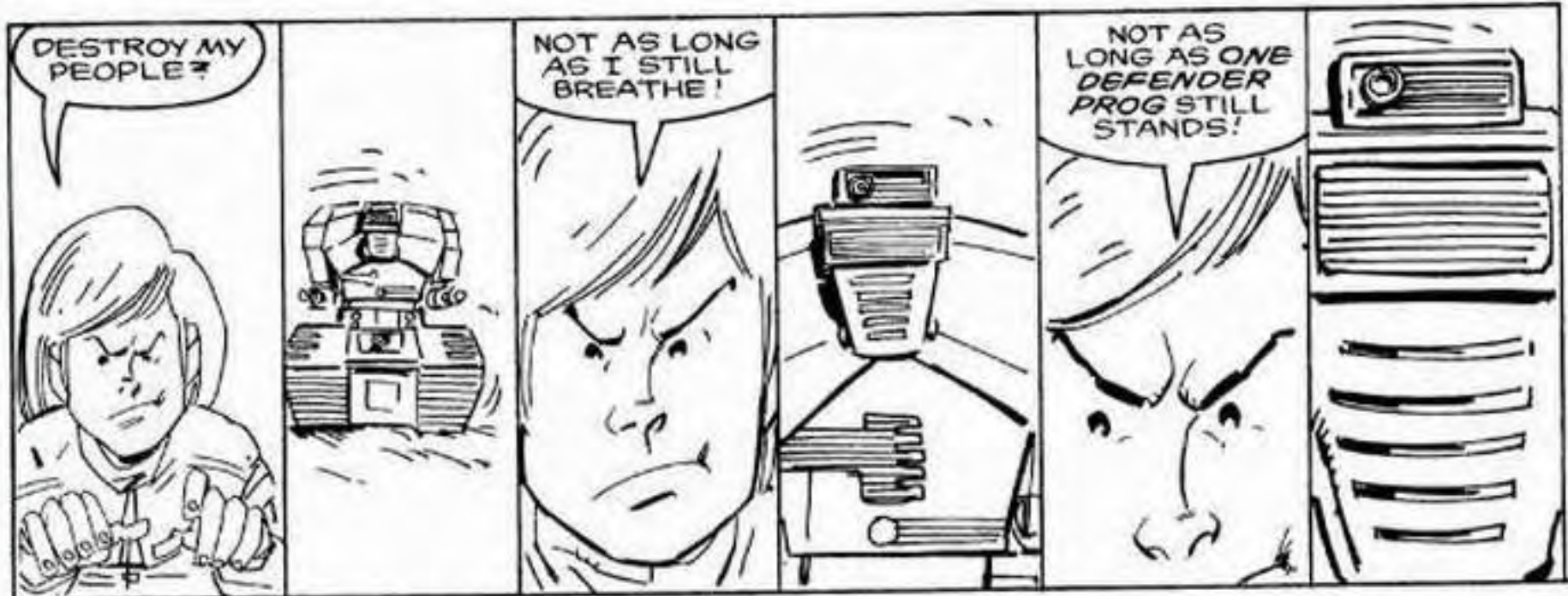



BUT IF THE DEFENDERS HAVE AN ENERGY CRYSTAL TO POWER THEM-- THEN THE DEMONS MUST HAVE ONE, TOO--

THE ONLY QUESTION IS: WHERE?

IT WOULD BE NEARBY--THE DEMON PROGS NEED IT TO PROVIDE A STEADY STREAM OF POWER--IT--



THERE! THAT GLOW! IT MUST BE THE DEMON PROG'S CRYSTAL!

YES, ALEX-7, NOW YOU MUST USE OUR PROGS TO DESTROY IT-- ONLY THAT WILL TERMINATE THE DEMON PROGS PERMANENTLY!



"AND YOU MUST DO IT-- BEFORE THEY DESTROY OUR ENERGY CRYSTAL!"



"LET NOTHING STOP YOU--LET NOTHING DISTRACT YOU FROM YOUR GOAL!"



"BUT ALWAYS REMEMBER TO MAINTAIN A STRATEGY, ALEX-7--IN THE END, THAT WILL ENSURE YOUR VICTORY!"



"I HAVEN'T FORGOTTEN THAT, MEGA-SAKA-- THAT'S WHY I MADE SURE TO PROTECT OUR ENERGY CRYSTAL WITH AT LEAST ONE DEFENDER PROG!"

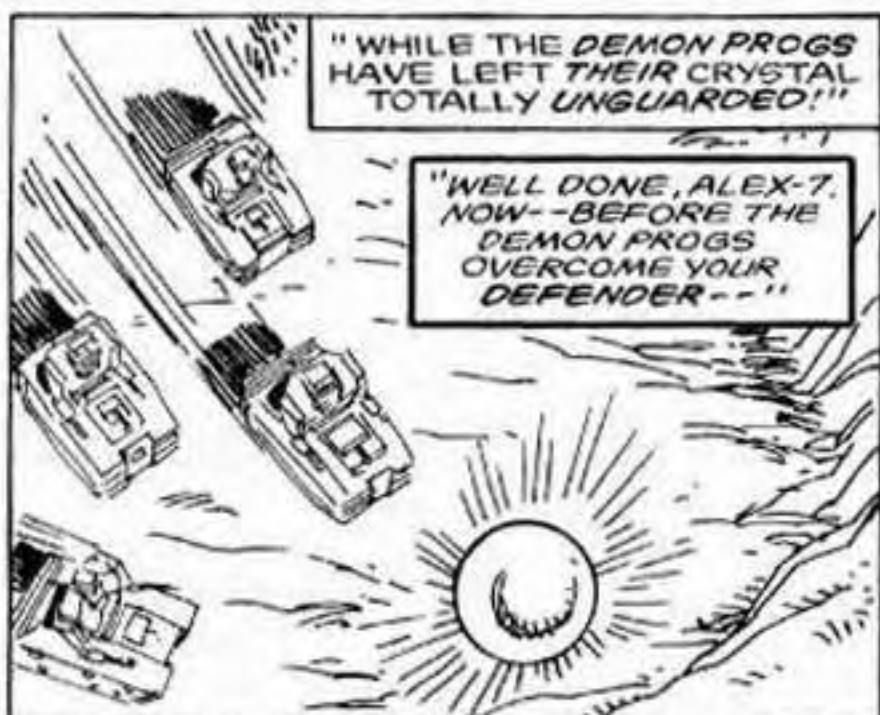

"WHILE THE DEMON PROGS HAVE LEFT THEIR CRYSTAL TOTALLY UNGUARDED!"

"WELL DONE, ALEX-7, NOW--BEFORE THE DEMON PROGS OVERCOME YOUR DEFENDER--"

**DESTROY THE
CRYSTAL!!**

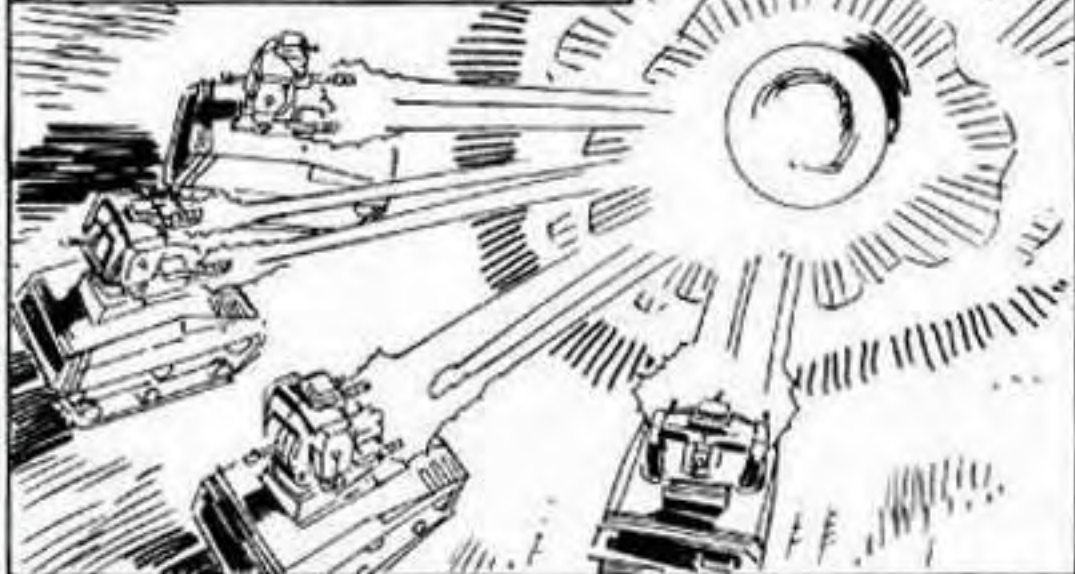

**THAT'S IT!! WE
BEAT THEM!! THE
DEMON PROGS
ARE FINISHED!!**



**BUT THERE ARE
MANY MORE PROGS
AND CRYSTALS
WITHIN THE
ZYTON CRAFT.**



**MAYBE,
MEGA SAKA...
BUT WHAT
GOOD ARE
THEY--**

**"-- WHEN THE ZYTONS
WILL NEVER GET THE
CHANCE TO USE THEM!"**

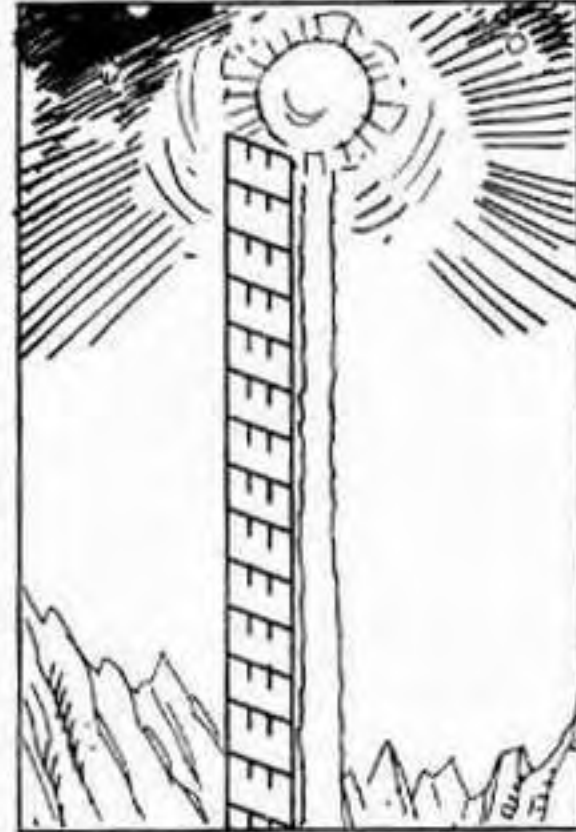
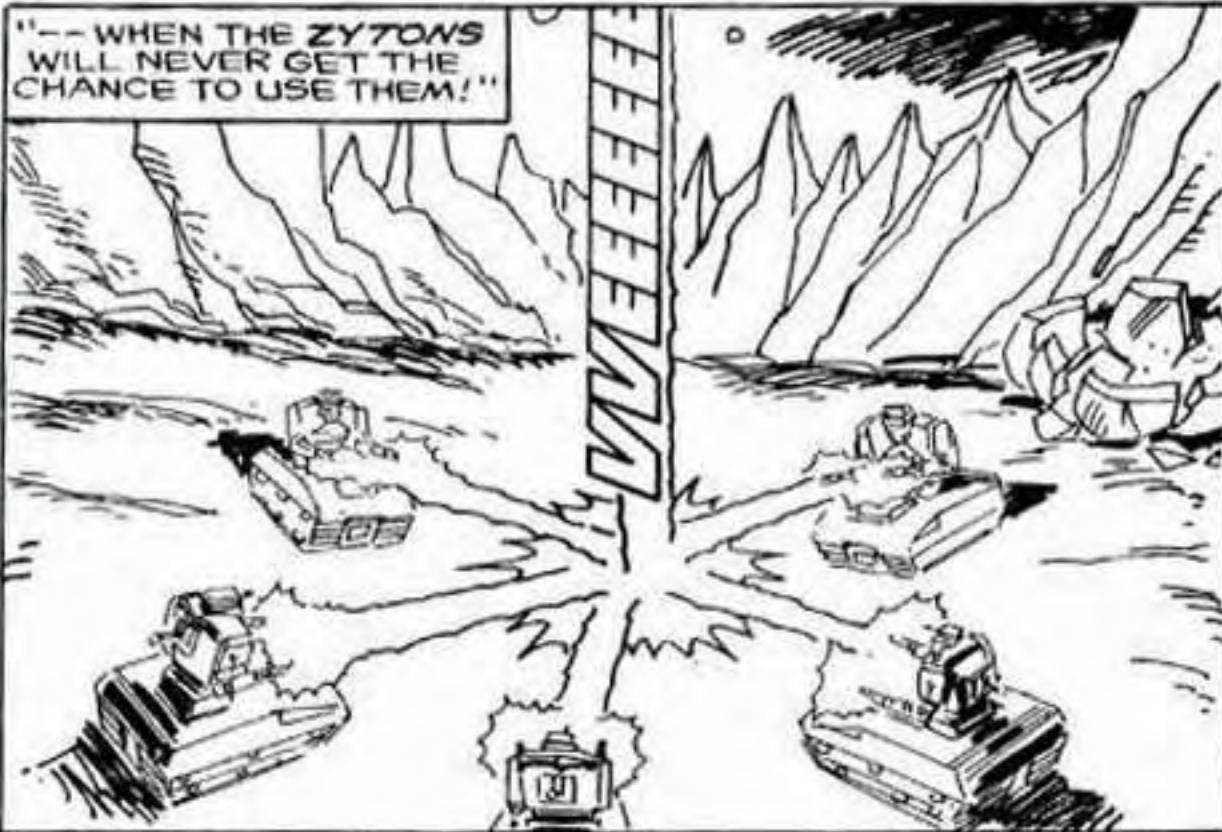

IN THE SILENCE OF SPACE, THE ENEMY IS DESTROYED--

-- AND THE BATTLE-WEARY PEOPLE OF THIS LAND BREATHE A SIGH OF RELIEF.

THEY ARE ALIVE... THEY HAVE SURVIVED. BUT THEIR LIVES HAVE BEEN FOREVER CHANGED.

SOMEONE-- SOMETHING-- EXISTS WITHIN ITS COLD STEEL WALLS--

AND WHOEVER HE IS...

...HE IS THEIR HERO.

NO LONGER CAN THEY DENY THE EXISTENCE OF OTHER CIVILIZATIONS...

NO LONGER CAN THEY IGNORE THE PURPOSE OF THE HIGHTOWER.



TRULY, ALEX-7-- YOU ARE A SYMBOL OF HOPE.

YOU HAVE GIVEN ME THE WILL TO CONTINUE-- TO SEARCH FOR OTHERS WITH THE STRENGTH OF MIND TO HARNESS THE POWER OF THE DEFENDER PROGS.

I MUST GO NOW. THERE IS MUCH FOR ME TO DO.



YOUR PEOPLE WANT YOU, ALEX-7. JOIN THEM.



LOOK! IT'S ALEX-7!

HE'S THE ONE! HE SAVED US ALL!



OH, SON-- WE WERE SO AFRAID YOU'D BEEN HURT!

BUT INSTEAD-- YOU SAVED OUR WORLD FROM DESTRUCTION!

I DIDN'T DO IT, ALONE FATHER-- I HAD HELP... FROM THE STARS.



ONE DAY I WILL RETURN, ALEX-7-- AND WITH ME, I WILL BRING A TEAM OF BEINGS LIKE YOU--

-- BEINGS WHO I WILL NURTURE AND TRAIN UNTIL THEY ARE READY TO CHALLENGE THE ZYTON EMPIRE-- UNTIL THEY ARE READY TO BECOME--

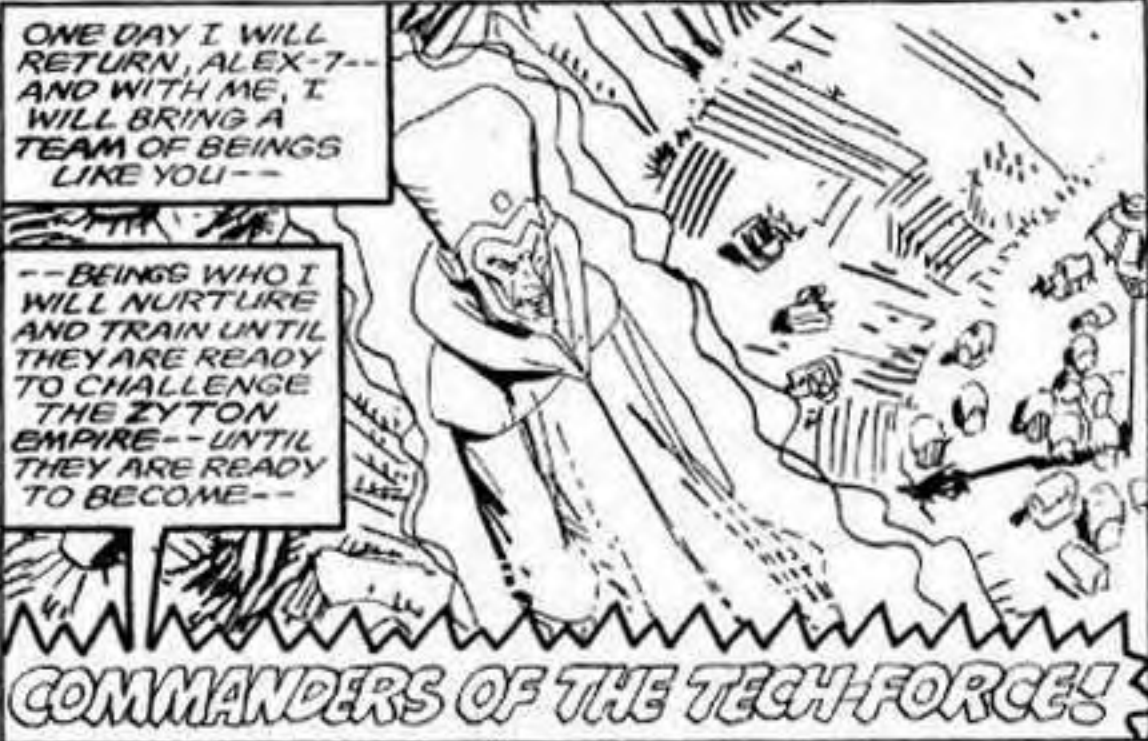

COMMANDERS OF THE TECH-FORCE!

TECHFORCE OPERATIONS MANUAL



This Operations Manual will give you the basic training required for all beginning levels of TECHFORCE control— Direct Control, Strategic Programming, Battle Patterns, and Synchro-Team.

With diligent practice, you will develop Ultimate TECHFORCE Control. You will attain Maximum TECHFORCE Power.

PREPARE
YOURSELF FOR
CONTROL OF THE
TECHFORCE
POWER





TABLE
OF
CONTENTS

I. SYSTEM SET-UP

A. System Components	1-3
B. Computer Command Console—Keyboard	4-5
C. Operations Reference Card	6
D. Computer Command Console Setup	6-7
E. PROG Setup	8-9

II. BASIC OPERATIONS

A. Powering Up the Consoles	10
B. Powering Up and Assigning PROGs	10-11
C. PROG Movement Direct Control	11
D. Invazer™ Cannons	12
E. Powering Down	10

III. GAMES: DIRECT CONTROL ONE-ON-ONE

A. Battle	13
B. Barriers	13
C. Capture The Crystal	14

IV. ADVANCED OPERATIONS

A. Strategic Programming	15-17
B. Battle Patterns	18-19

V. GAMES: STRATEGIC PROGRAMMING ONE-ON-ONE

A. Battle	20
B. Barriers	20
C. Capture The Crystal	21

VI. GAMES: BATTLE PATTERNS AGAINST THE COMPUTER

A. Roundup	22
B. Protector	22
C. Laps	23

VII. MULTIPLE PROG CONTROL

A. Assigning Multiple PROGs	24
B. Multiple PROGs—Direct Control	24
C. Multiple PROGs—Direct Control With Synchronized PROGs	25
D. Multiple PROGs—Direct Control With Battle Patterns	25
E. Multiple PROGs—Strategic Programming	26-28

VIII. GAMES: STRATEGIC PROGRAMMING WITH MULTIPLE PROGs

A. Battle	29
B. Capture The Crystal	29
C. Destroy The Crystal	30

IX. GENERAL INFORMATION

A. Important System Notes	31-32
B. Troubleshooting	33
C. System Expansion	34
D. Warranty Information	35

TECHFORCE SYSTEM COMPONENTS

Your TECHFORCE Strategy-Action Battle Set Contains:

- 1 Main Computer Command Console (with antenna)
- 1 Auxiliary Computer Command Console
- 1 Console Connector Cable
- 2 Motorized Drive Bases
- 2 Blue Defender PROG™ Figures
- 2 Red Demon PROG™ Figures
- 2 Drive Base Caps
- 2 Energy Crystals
- 3 Battle Barriers
- 2 PROG I.D. Tag Sets
- 1 Comic Book/Operations Manual with 5 Operations Reference Cards

MAIN COMPUTER COMMAND CONSOLE

The Computer Command Consoles transmit your commands to the Drive Bases in the PROG figures. Batteries installed in the Main Console power both Consoles (See Console Setup on pages 6, 7). This Console also contains the Power On switch and the radio signal antenna. An optional accessory, the Axlon Sonic Decoder, plugs into the back of this Console (See Accessories on page 34).

AUXILIARY COMPUTER COMMAND CONSOLE

The Auxiliary Console is connected to the Main Console with the Console Connector Cable. The Auxiliary Console needs no batteries.

CONSOLE CONNECTOR CABLE

Transmits power from the Main Console to the Auxiliary Console. Transmits signals from the Auxiliary Console to the antenna on the Main Console (and out to the Drive Bases).

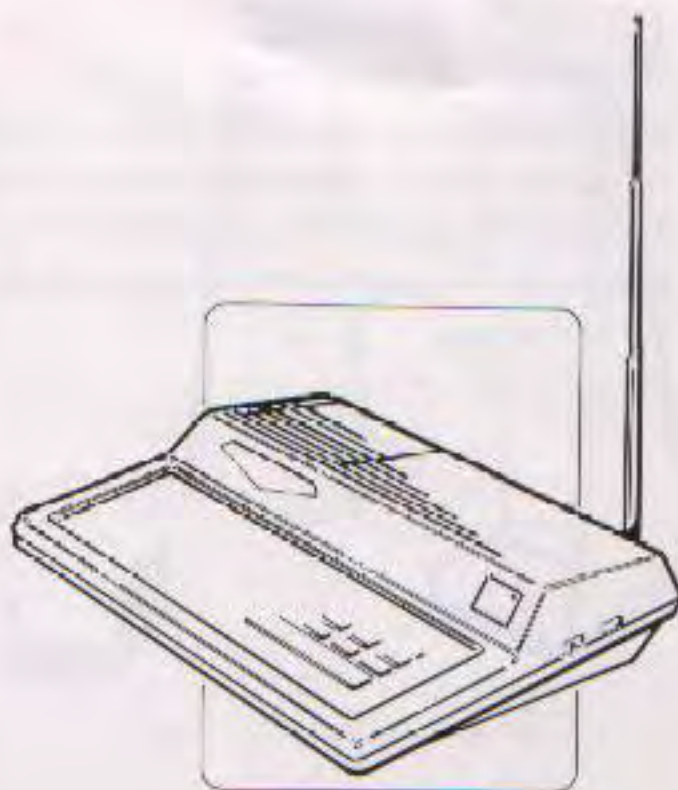

Main Computer Command Console

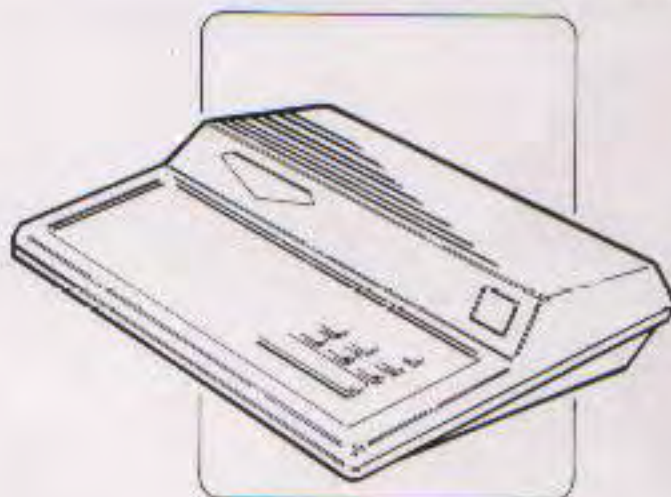

Auxiliary Computer Command Console



Console Connector Cable



MOTORIZED DRIVE BASES

The Drive Bases are the mobile drive units. They receive and execute commands from the Computer Command Consoles. Infra-red Invazer™ Cannons (and Invazer Receptors) are mounted in the front of each Drive Base.

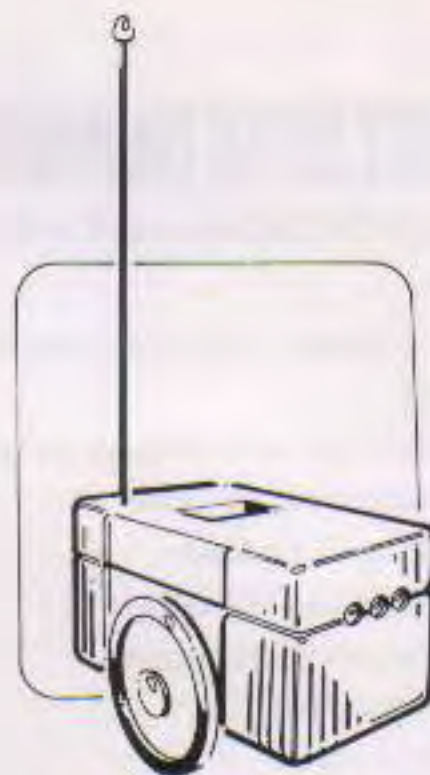

Motorized Drive Bases

PROG™ FIGURES

Interchangeable PROG Figures plug onto the Drive Bases, creating mobile PROGs.

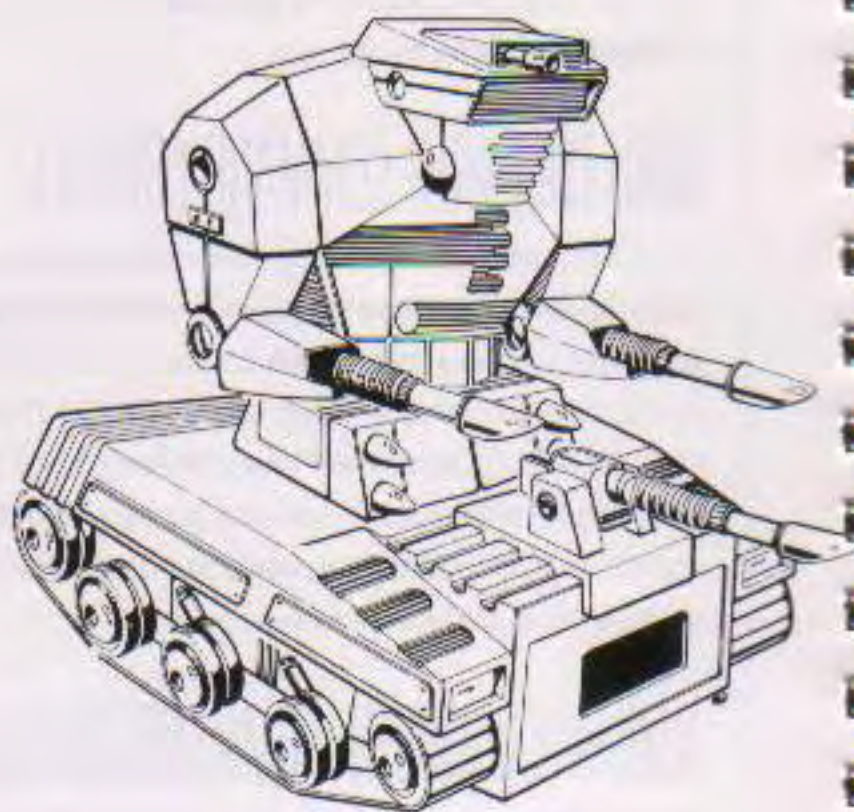

PROG-Protector

DRIVE BASE CAPS

Allows Invazer Cannons in the Drive Bases to operate without attaching a PROG Figure.

NOTE: Invazer Cannons will not operate unless a PROG Figure or a Drive Base Cap is plugged into the Drive Base.



Drive Cap Base



ENERGY CRYSTALS AND BATTLE BARRIERS

Accessories for game play and scoring.

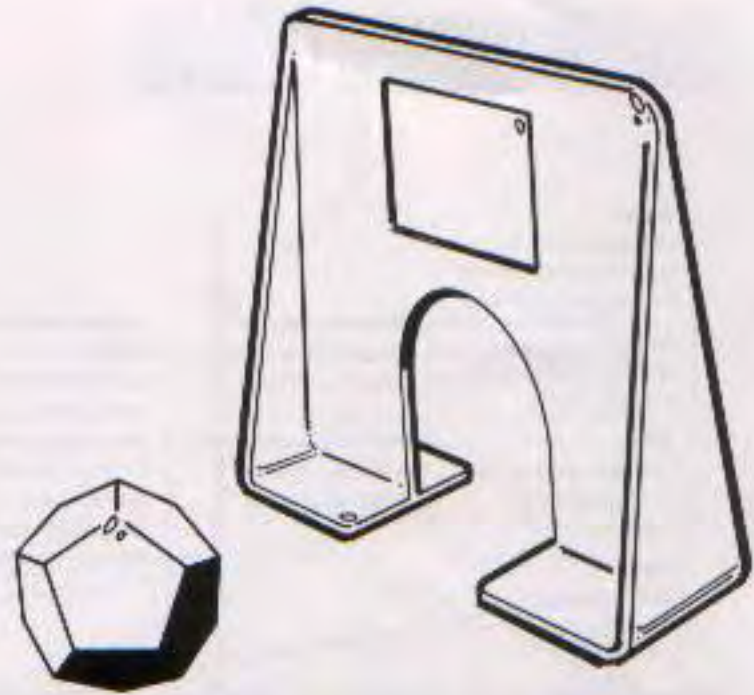

Energy Crystals and Battle Barrier

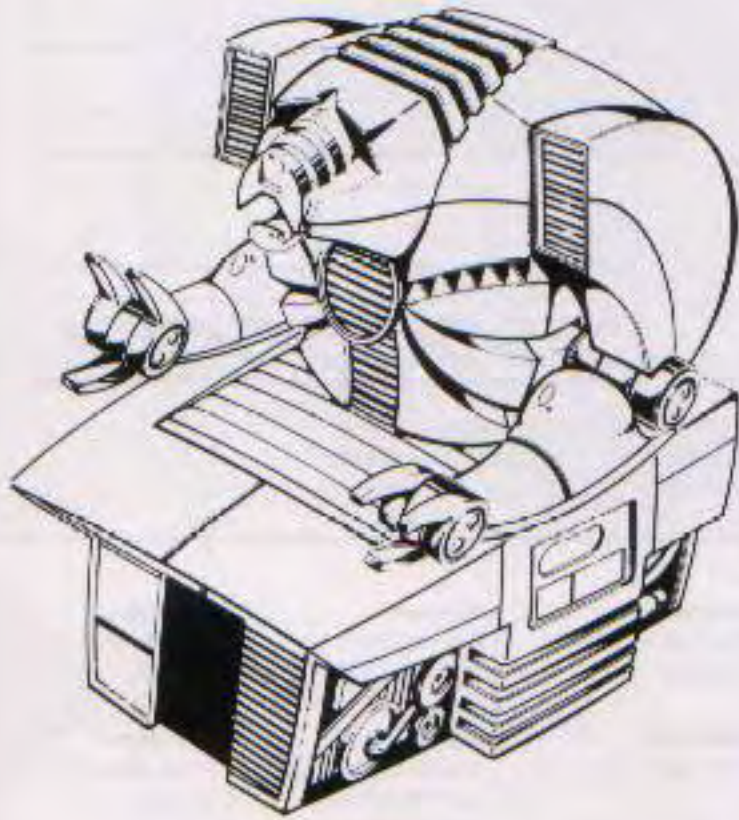

PROG-Demon

PROG I.D. TAGS

Assists in PROG identification on the battlefield.

OPERATIONS REFERENCE CARDS

Quick reference to the various system and game setup sequences.



PROG I.D. Tags

COMPUTER COMMAND KEYBOARD

Reset

Erases all previous programming (except for assigning PROGs).

Assign

Assigns PROGs to one of the Consoles.

Time

Sets time duration of move in Strategic Programming.

Clear

Erases previous instruction only.

Numeric Keypad

Selects PROGs for assigning to console or for programming instructions; programs time intervals for length of actions.

Action Indicator Light

Green light blinks when PROG is being controlled or waiting for a command. In Strategic Programming, light stays on between rounds.

Power Indicator Light

Red light glows when power switch is in the "on" position.

A, B, C Functions

Controls additional functions on future accessory PROG figures.

Fire

Causes PROGs to fire invisible, infra-red Invazer™ Beam. Invazer beams can stun an enemy PROG.

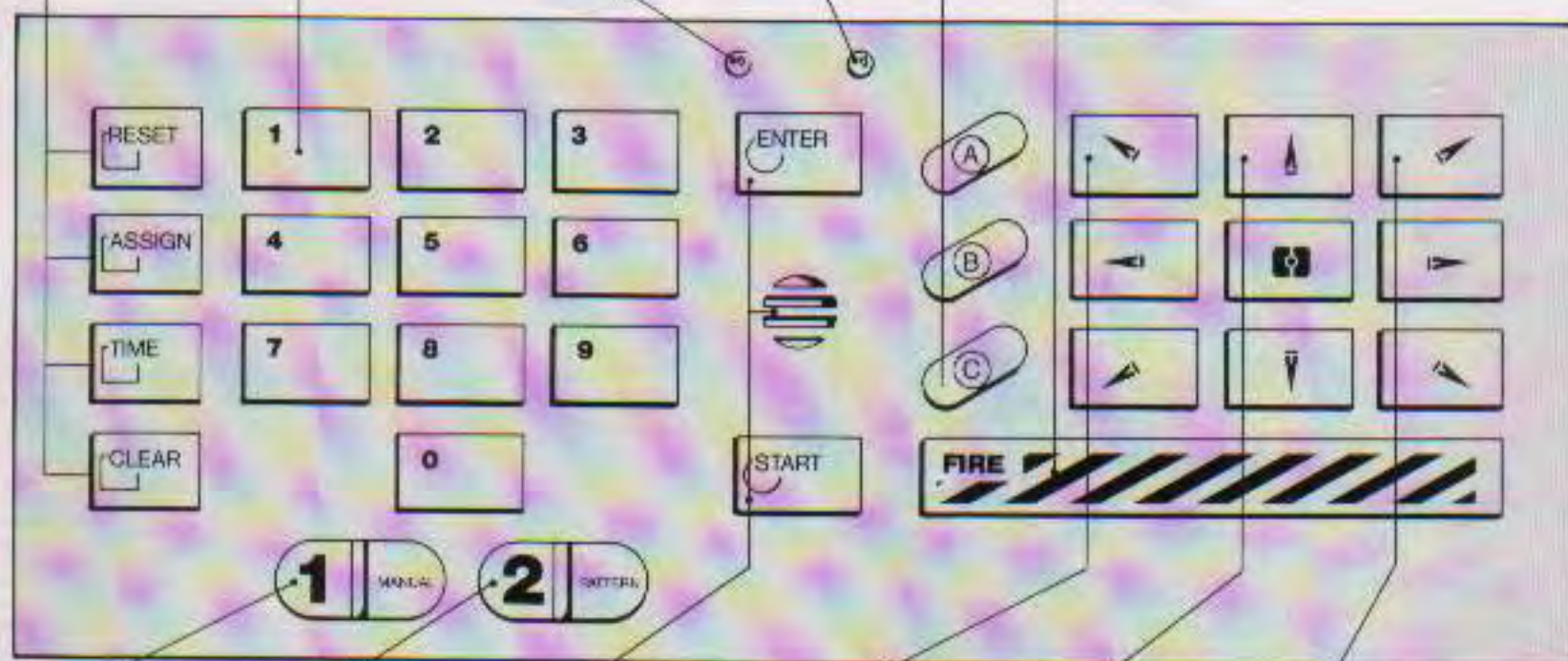

Game 1/Manual

Dual use key turns on Game 1 or adds PROG to a Synchro-Team.

Game 2/Pattern

Dual use key turns on Game 2 or puts PROG in a Battle Pattern.

Enter

Locks commands into the Computer's memory.

Speaker

Electronic beeps indicate instructions entered into and accepted by the computer.

Start

Releases the Computer to execute the action.

Left Turn

Right wheel drives forward.

Spin Left

PROG spins left on axis.

Back Left

Right wheel drives backward.

Forward

Both wheels drive forward.

Pause

When used in Strategic Programming, causes a timed delay in the action.

Back

Both wheels drive backward.

Right Turn

Left wheel drives forward.

Spin Right

PROG spins right on axis.

Back Right

Left wheel drives backward.



COMPUTER COMMAND CONSOLE

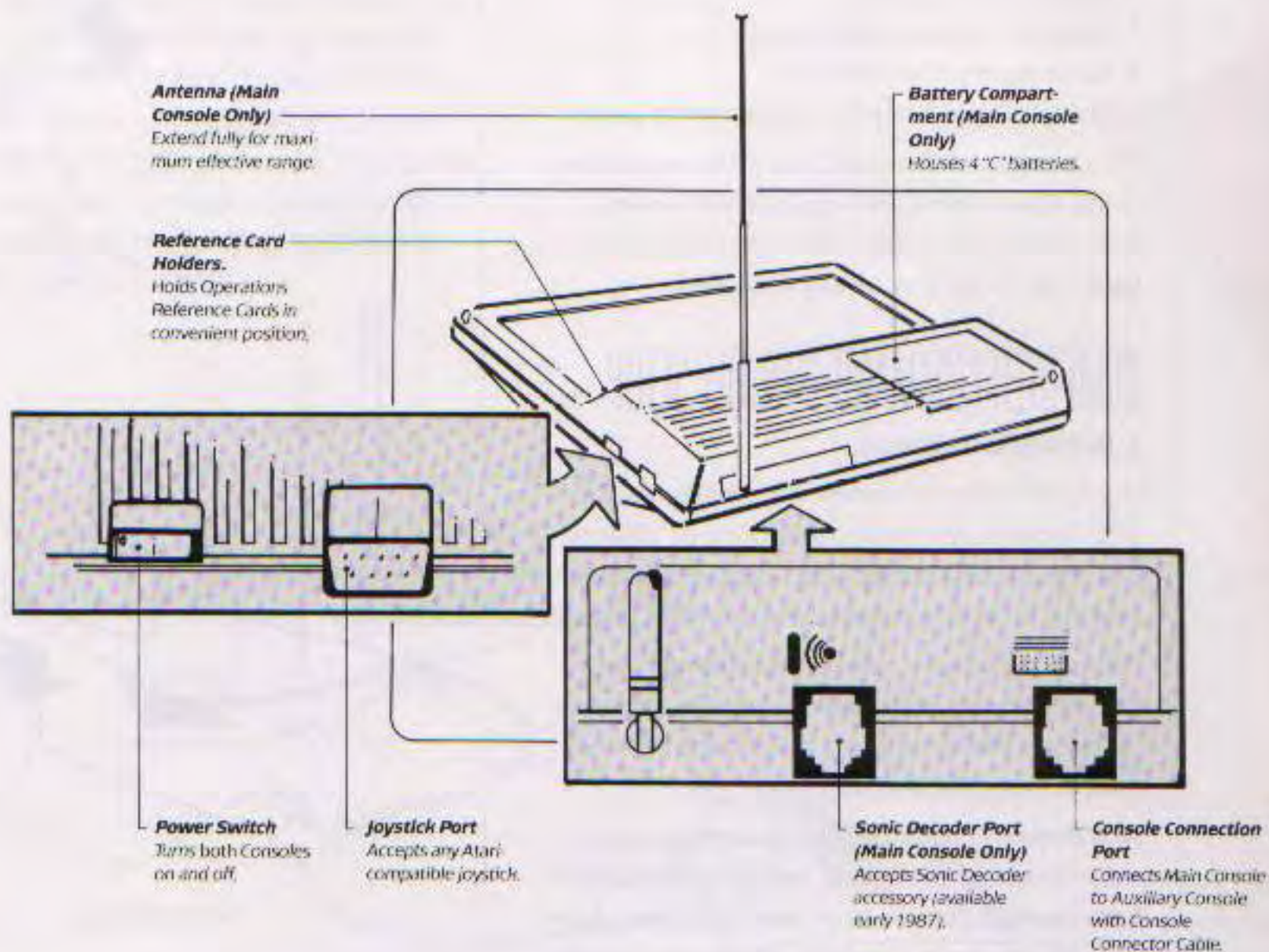

OPERATIONS REFERENCE CARDS:

1. Powering Up/Assigning PROGs
2. Direct Control Games
3. Strategic Programming Games
4. Battle Against the Computer
5. Multiple PROG Strategic Programming Games

The Operations Reference Cards in the rear pocket of this manual are a quick guide to the various system and game setup sequences. The Reference Cards rest on the Consoles as illustrated.

COMPUTER COMMAND CONSOLE SETUP

1. Battery Installation:

The Main Computer Command Consoles requires 4 "C" batteries. (We recommend Duracell® alkaline batteries for best results.) The Auxiliary Console is powered only when connected to the Main Console.

Remove the battery cover as shown. Insert each battery, being careful to align the plus (+) and minus (-) signs on the battery with those in the battery compartment. Replace the battery cover.

NOTE: Main Console battery replacement is required when the Drive Bases will not receive signals from the Main Console (even when antenna is fully extended and Drive Base batteries are OK). Console batteries will last 3 to 4 times longer than Drive Base batteries.

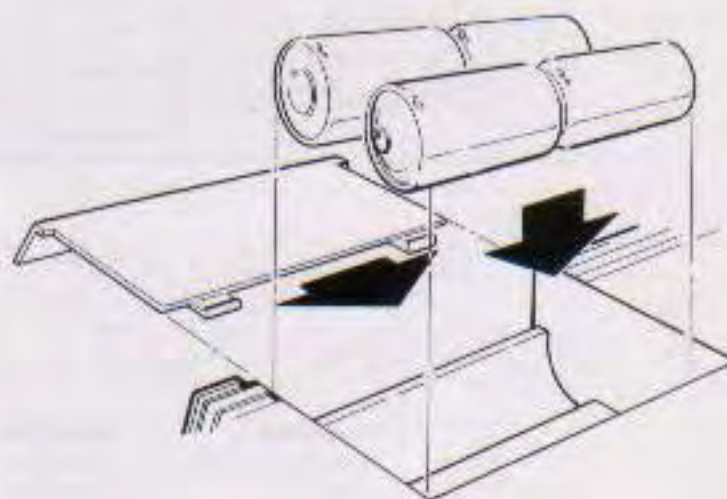
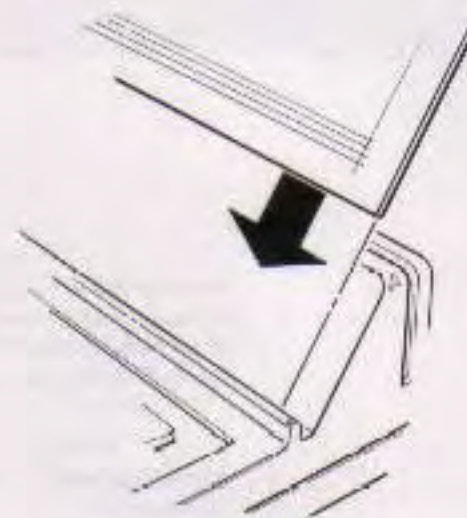

Battery Installation



2. Connecting Consoles:

The Auxiliary Console receives its power from the Main Console and transmits its instructions through the antenna on the Main Console. This requires the Auxiliary Console to be connected to the Main Console with the included Console Connector Cable. Plug one end of the Connector Cable into the Auxiliary Console port in back of the Main Console. Plug the other end into the Main Console port in back of the Auxiliary Console.

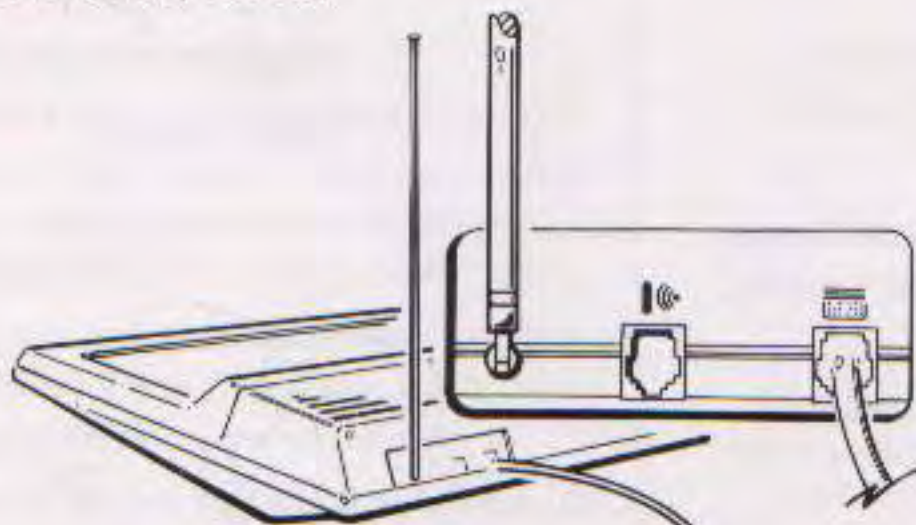

Connecting Consoles

WARNING: NEVER CONNECT THE TECHFORCE COMPUTER COMMAND CONSOLES TO A TELEPHONE OR TELEPHONE OUTLET! SEVERE SYSTEM DAMAGE MAY OCCUR.

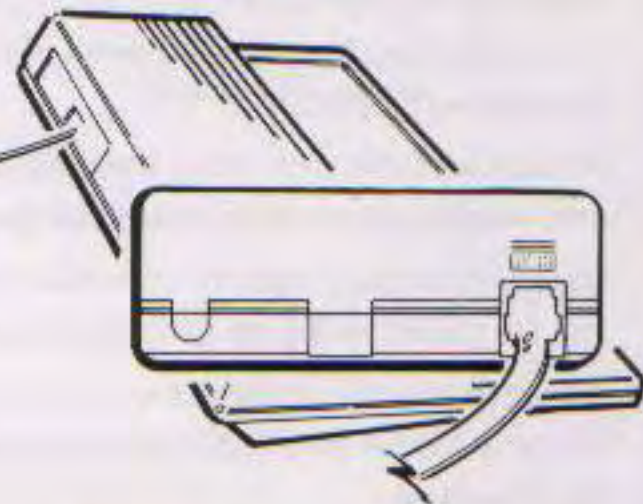

3. Joystick Connection (Optional)

For joystick control of the PROGs (instead of using the Direction Keys on the Console Keyboard), a joystick can be connected to the console. A standard Atari-compatible joystick plugs straight into the Joystick port on the side of each Console.

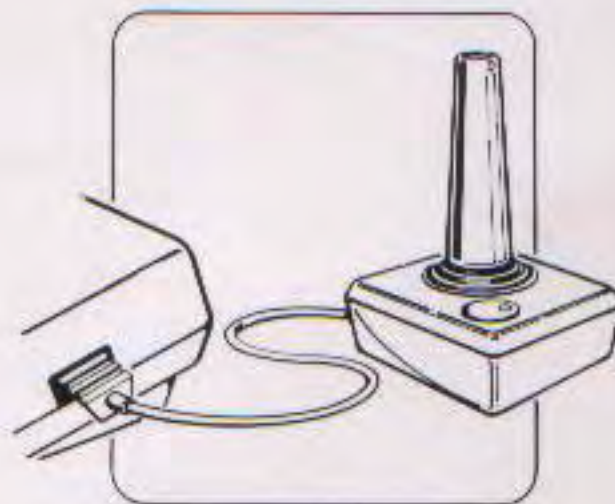

Joystick Connection

PROG SETUP

1. Battery Installation:

Each Drive Base requires 4 "AA" batteries. (We recommend Duracell® alkaline batteries for best results.)

Open the battery compartment on the bottom of each Drive Base. Insert the batteries, making sure to align the plus (+) and minus (-) signs on the battery with those in the battery compartment. Close the battery compartment.

NOTE: When Drive Bases become noticeably slower, you will need to replace their batteries.

2. PROG Figure Attachment:

Lower PROG over Drive Base (antenna goes through hole in PROG Figure). Make sure Invazer™ Cannons in Drive Base face forward.

Snap PROG into place. Make sure the plug inside the PROG pushes into the socket on the top of the Drive Base.

3. Drive Base Cap Attachment:

Attaching the Drive Base Cap allows you to design your own PROG figures using various brands of interlocking blocks.

Fit Cap over Drive Base, fitting the Drive Base antenna through the hole in the Drive Base Cap.

Make sure the plug under the Drive Base Cap pushes into the socket on the top of the Drive Base.

NOTE: Invazer™ Beam will not work unless a PROG™ Figure or a Drive Base Cap is correctly attached to the Drive Base.

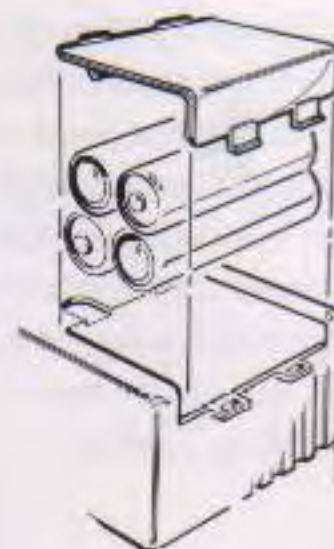

Battery Installation

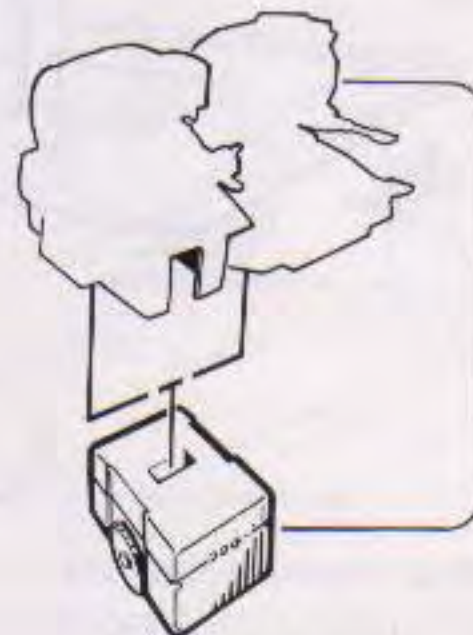

PROG Figure Attachment

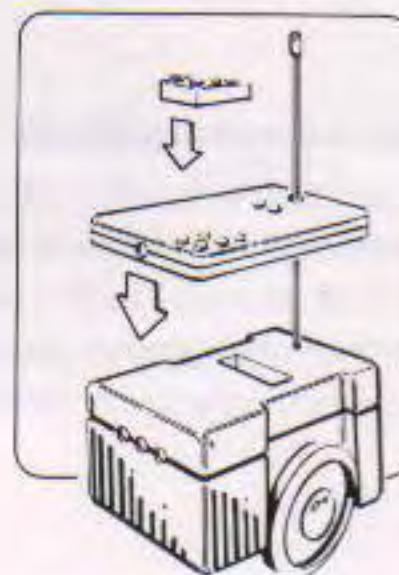

Drive Base Cap Attachment



4. Figure Identification:

The TECHFORCE Basic Set comes with 2 sets of 8 velcro-backed plastic PROG I.D. tags. The tags are necessary when there are more than one PROG per team.

Attach the tag to the PROG by sticking the velcro patch on the back of the tag to the velcro patch on the PROG.

Assign one team's PROGs their numbers (from 1 to 8), then assign the other team's PROGs their numbers (from 1 to 8).

5. Drive Base Identification:

For correct communication with the Computer Command Consoles, each Drive Base must be identified by number, 1 through 8 (matching the PROG I.D. number assigned in Step 3 above).

The Drive Base identification number is set by a dial on the bottom of the Drive Base. If a PROG has been assigned Number 1, set the dial to 1.

Important: Be sure the Drive Base is turned Off before setting the dial.

NOTE: All Drive bases on the same team that are set to the same dial setting will react simultaneously to any given command.

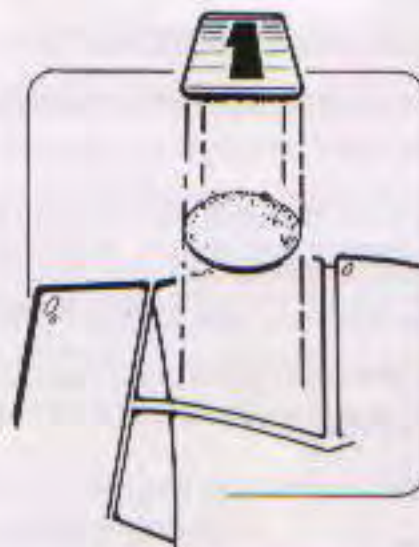
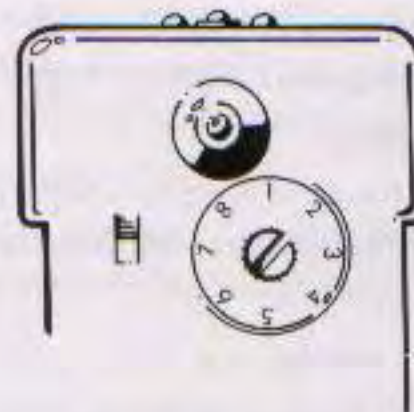

Figure Identification



Drive Base Identification

POWERING UP THE CONSOLES

(See Operations Reference Card #1)

Always turn on Consoles *before* turning on Drive Bases.

1. Push the On-Off switch on the Main Console to the **ON** position. This turns on both Consoles (with the Connector Cable installed). The Power On Indicator Light will light up, and the Console will emit 3 beeps.
2. Extend the antenna on the Main Console.

POWERING UP AND ASSIGNING PROGS

(See Operations Reference Card #1)

Players choose PROGs and Consoles.

1. Assigning one PROG per team:

PLAYER ONE:

1. Turn on the Drive Base by pushing the On-Off switch on the bottom of the Drive Base to the **ON** position.
2. Press the **Assign** key on the Console.
3. Press the **Number** key of the PROG to be assigned (the **1** key if Drive Base dial is set to "1").
4. Press the **Start** key. To indicate assignment, the PROG will move quickly back and forth, and the Console will emit 3 beeps.

PLAYER TWO:

Method 1: Repeat the above steps with the other Console and the other PROG.

Method 2 (short cut): Turn on the Drive Base. Press the **Assign** key. Press the **Start** key.

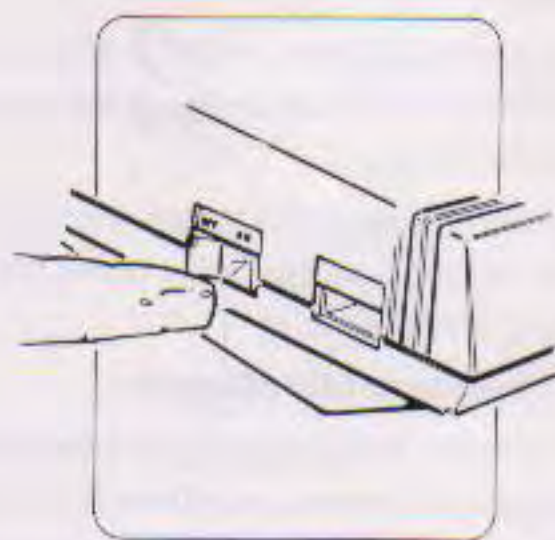

Console On-Off Switch

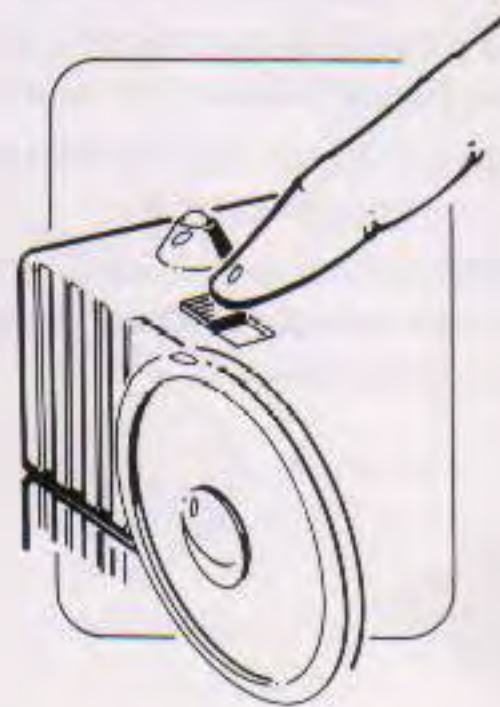

Drive Base On-Off Switch

2. Assigning two or more PROGs per team:

PLAYER ONE:

1. Turn on all of Player One's Drive Bases by pushing the On-Off switches on the bottoms of the Drive Bases to the **ON** position.
2. Press the **Assign** key on the Console.
3. Press the **Number** keys of each of the PROGs to be assigned. (To assign PROGs 1 and 2, press "101" then "2.")
4. Press the **Start** key. To indicate assignment, the PROGs will briefly move back and forth, and the Console will emit 3 beeps.

PLAYER TWO:

Method 1: Repeat the above steps with the other Console and the other PROGs.

Method 2 (short cut): Turn on the Drive Bases. Press the **Assign** key. Press the **Start** key.

3. Changing PROG assignments:

To change assignment of a PROG (or PROGs) from one Console to the other Console:

1. Turn the PROG (or PROGs) off.
2. Turn the PROG (or PROGs) back on.
3. On the appropriate Console, press the **Assign** key, the appropriate **Number** key (or keys), and the **Start** key.

NOTE: If you assign two PROGs with the same ID number to the same console, both PROGs will react simultaneously to all commands given to that number. Check the Drive Base dials to be sure that all PROGs assigned to the same console have different ID numbers.

PROG MOVEMENT: DIRECT CONTROL

(See Operations Reference Card #2)

PROGs are moved by Direct Control using the Direction Keys on the Console keyboards or with an optional joystick (See Joystick Connection on page 7). The PROG moves continuously or fires continuously as long as a key is held down. Moving a PROG is simple:

1. Press the PROG's **Number** Key on the Numeric Keypad.
2. Press any **Direction** Key.

OR

Move the joystick in the desired direction.

3. Release the Key or joystick when end of motion is desired.

To Direct Control 2 or more PROGs simultaneously, see Multiple PROGs—Direct Control with synchronized PROGs, page 25.

NOTE: PROGs are faster on a hard, flat surface, slower on carpet. PROGs may not work on some types of carpet.

NOTE: Pressing two keys has no effect, except when pressing Forward and Spin Left or Right, or when pressing Back and Spin Left or Right. These combinations produce Turns.



INVAZER™ CANNONS

PROGs fire invisible Invazer beams at each other. When a PROG has been hit head-on (right into its Invazer Cannon) by an Invazer beam, it is temporarily stunned. A PROG indicates it has been "hit" by the flashing green lights on its body. It cannot move or fire for 10 seconds.

The Invazer Cannon is mounted in the front of the Motorized Drive Base. It has a range of approximately 5 feet.

To fire an Invazer beam, press the **Fire** Key on the Console or on the joystick. No Direction Keys may be in use while firing.

Precise aim is crucial. Maneuver directly in front of the opposing PROG and aim your Invazer Beam directly at the Invazer Cannon in the front of its Drive Base. The Invazer beam is narrow, so aim carefully.

POWERING DOWN

Powering Down the system simply requires turning off the Main Console and all Drive Bases. Two energy-reserve features are built into the system to remind you to power down:

1. When no Console keys have been pressed for about 10 minutes, the Consoles will beep, telling you to turn the Main Console **off**.
2. When the Main Console has been turned off, but the Drive Bases are left on, they will occasionally rock back and forth, reminding you to turn them off.

NOTE: Drive Base batteries will drain more rapidly if left on.

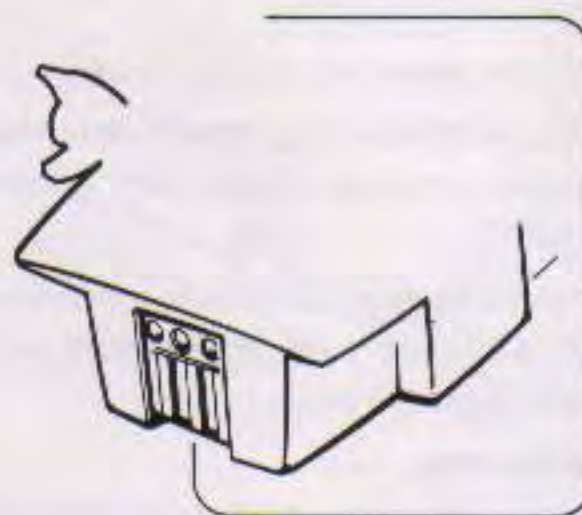

Invazer Cannon

BATTLE

(See Operations Reference Card #2)

On a routine scouting mission near the village border, a Demon PROG surprises a Protector PROG. They battle until one PROG is chased away. Be the first PROG to score 3 "hits" on the enemy. Choose your PROGs!

SETUP

1. Assign a Protector PROG to one Computer Command Console and a Demon PROG to the other Console.
2. Position PROGs, facing away from each other, at opposite ends of the battlefield (4' x 6' is a good size).

ACTION

3. The game begins when the Demon PROG makes its first move.
4. Use Direct Control to maneuver PROGs into Invazer Cannon range. Blast the enemy with an Invazer Beam.
5. The winner is the first PROG to score 3 "hits."

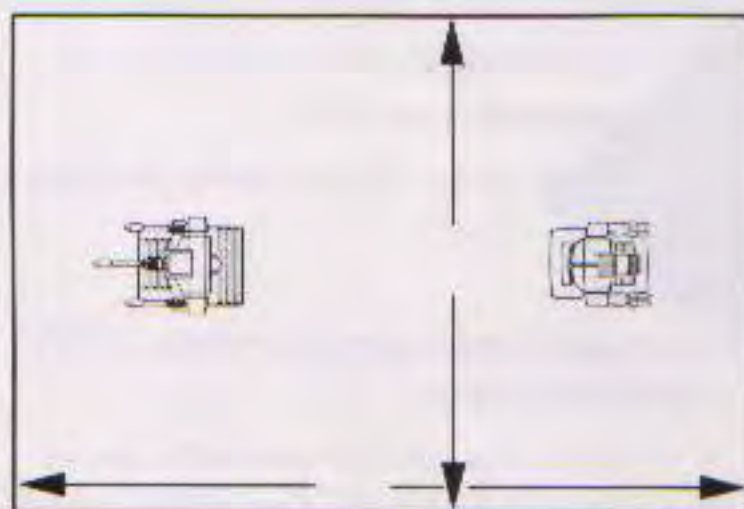

Battle

BARRIERS

Energized Battle Barriers border the village. The PROGs gain energy by destroying the Barriers. Be the first PROG to knock down 2 of the Barriers.

SETUP

1. PROGs are positioned on both sides of the Barriers, facing away from each other, as shown.
2. The red side of the Barriers faces the Protector PROG. The blue side faces the Demon PROG.

ACTION

3. The game begins when the Demon PROG makes its first move.
4. PROGs must knock over the Barriers so that their color faces up. Winner is first PROG with at least 2 Barriers of its color facing up (no matter how it was knocked over).

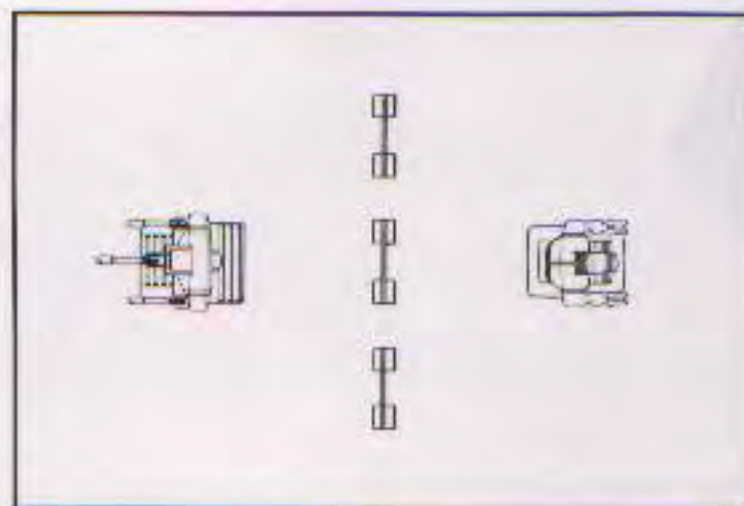

Barriers

CAPTURE THE CRYSTAL

Once inside the Barriers, Demon PROGs attempt to steal the Energy Crystals from the village. Be the first PROG to gain control of the Crystal and push it into your Crystal Goal.

SETUP

1. Crystal Goals are constructed at each end of the battlefield by laying a Barrier on its side, as shown.
2. Position the PROGs in front of the Barriers, facing away from each other.
3. Place one Energy Crystal in the center of the battlefield.

ACTION

4. The game begins when the Protector PROG makes its first move.
5. The winner is the first to retrieve the Energy Crystal, bring it back to the Goal, and push it into the Goal.
6. Longer games may be played by counting each goal as one point. The winner is the first to reach 10 points.

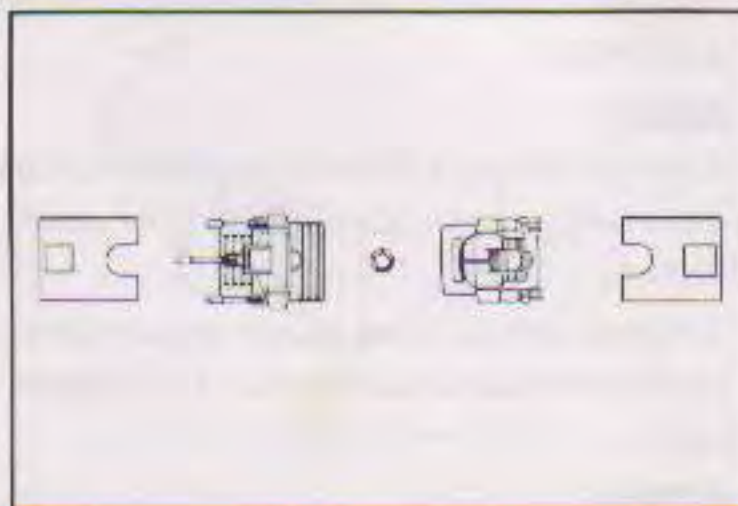

Capture the Crystal



STRATEGIC PROGRAMMING:

1. Introduction

PROGs are distinguished from all previous remote fighters by their ability to be programmed for a sequence of battle actions. Thus the name—PROG.

Programmed battles are the ultimate in strategic challenge. Whereas Direct Control battles are won with fast thinking and instant reflexes, Strategic Programming battles are won by the best thinkers, strong in both short-term tactics and long-term strategies.

Strategic Programming battles are fought in a series of rounds. The rounds are structured by controlling a variety of factors—how many actions per round, how those actions are distributed among the PROGs, and how long each action lasts (Time setting).

There are two types of battles that can be fought:

Game 1: Balance—Each PROG on a team performs 1-6 actions per round.

Game 2: BlitzPROG—Each team assigns 1-32 actions to any or all of its PROGs.

Since these games are identical for one-PROG teams, this section gives instructions for Game 2 (1-32 actions). For programming teams of two or more PROGs, see Multiple PROG Control, Strategic Programming, page 26.

NOTE: The Time length for each Forward motion, Backward motion, or Pause is preset at 1.5 seconds. The Time setting can be changed to time durations of 0.1 second to 5 seconds for each action. Changing Time setting is optional.

Optional Time setting is entered in tenths of seconds. (See Programming Procedures below.) For example:

Entry	Duration	
1	0.1 second	minimum duration
2	0.2 second	
10	1.0 second	
25	2.5 seconds	
50	5 seconds	maximum duration

IMPORTANT NOTE: Turns and spins are set for approximately 45 and 90 turns. Invazer fire is set for a 1 second duration.

2. Programming Procedures

(See Operations Reference Card #3)

SETUP

1. Press the **Reset** key.
2. Press the **Game 2** key.
The green indicator light on the console will light up.
3. Press the **Number** key(s) for the number of actions per round.
Choose 1-32 actions.
4. Press the **Time** key (optional).
5. Press the **Number** key(s) for Time duration setting—from 1 to 50 (optional).
6. Press the **Enter** key.
The Console will beep twice—"ready to accept actions."

NOTE: Both Computer Command Consoles may be programmed simultaneously.

PROGRAMMING

7. Press the **Number** key for the PROG to be programmed.
8. Enter actions with **Direction** keys. **Pause** key, or **Fire** key.
The Console will beep once each time a key is pressed—"entry accepted." The Console will not beep when the maximum number of actions (1-32) has been entered.
9. Press the **Enter** key.
The Console will beep twice—"programmed for upcoming round."

ACTION

10. Press the **Start** key.
The Console will emit three beeps. When the Start keys on both Consoles have been pressed, the PROGs on both teams will simultaneously perform the round of actions.

ALL FOLLOWING ROUNDS

For all following rounds, repeat steps **7-10** under Programming and Action above.

Repressing the **Start** key without entering new actions will cause the PROGs to repeat the last round of actions entered.

(Hint: If you are able to hit your opponent's PROGs with an Invazer Beam, that PROG will be stunned for 10 seconds of action time. This may be more than one round, depending on when in the round it is hit and the time duration per move.)

3. Clearing Entries from Programming

If you change your mind while programming the actions, the entries may be changed in one of two ways.

1. If the **Enter** key has not yet been pressed: press the Clear key, then re-enter new actions.
2. If the **Enter** key has been pressed: press the Number key of the PROG to be reprogrammed, then re-enter the new actions.

NOTE: Pressing a PROG's **Number** Key erases its previous programming. But once the **Start** Key has been pressed, all programming is locked in place.

STRATEGIC NOTE: You may handicap one player in Strategic Programming Games by giving him fewer moves per round (See Strategic Programming, pages 20, 21) or making his time duration per move shorter (See setting Time, pages 15, 16).

BATTLE PATTERNS:

PROGs can be programmed to perform Battle Patterns under automatic control of the Computer Command Consoles. A Battle Pattern is a pre-programmed set of actions that repeats itself indefinitely. This feature is used in two ways:

1. One player plays against the computer by programming one Console to control a PROG (or PROGs) with Battle Patterns. The player uses the other Console to Direct Control a PROG against the Patterns.

2. When there are more than one PROG on each team, a player can program one or more PROGs to perform preset Patterns, while another PROG is under Direct Command. (See Multiple PROG Control—next section.)

1. Programming Battle Patterns

A Battle Pattern can be programmed at any time during a Direct Control battle:

1. Press the PROG's **Number Key**.
2. Press the **Pattern Key**.
3. Press the **Number Key** of the desired pattern (See patterns below).

NOTE: To stop the Pattern and regain Direct Control of the PROG, simply press the PROG's **Number Key** again. (Pressing **Reset** also stops all movement.)

2. Battle Patterns by selection number

1. **Spray** fires forward in three directions. A good defensive pattern for protecting corners.
2. **Super Spray** spins, fires at approximately 90° intervals. A good backfield defensive pattern.
3. **Ultra Spray** spins, fires at approximately 30° intervals. A good midfield defensive pattern.
4. **Crazy Spray** spins and fires randomly. A good offensive pattern in enemy territory.
5. **Box Spray** moves backwards, turns right approximately 90°, fires, then repeats. A good defensive pattern to cover a large area.
6. **Sentry** moves forward approximately 24 inches, spins, then fires, repeats. A good protection pattern for large battlefields.
7. **Sentry Spray** moves forward, sprays, spins, repeats. A good midfield pattern for protecting the sidelines.
8. **Flank Guard** fires, turns approximately 90°, moves forward approximately 26 inches, turns approximately 90°, fires, and repeats. A good backfield defensive pattern for a large battlefield.
9. **Tack Advance** zig-zags forward slightly, firing. A good offensive pattern.
10. **Random** moves forward, backward, turns, fires and spins, all completely randomly. A maniacal wild card.

Once a PROG has been instructed to perform a pattern, it will do so until instructed to stop. If it is hit with an **Invazer™** beam while performing a pattern, it will be stunned for 10 seconds, then resume the pattern.



1. Spray

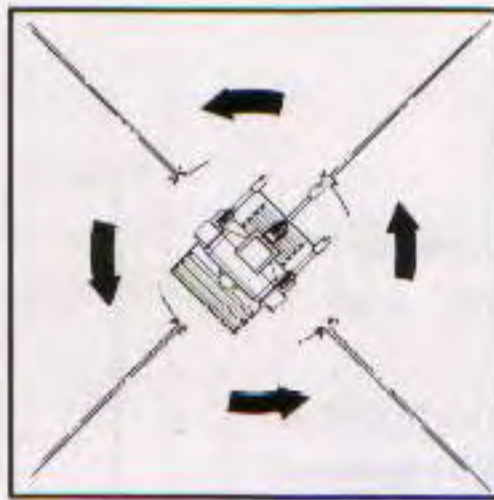

2. Super Spray

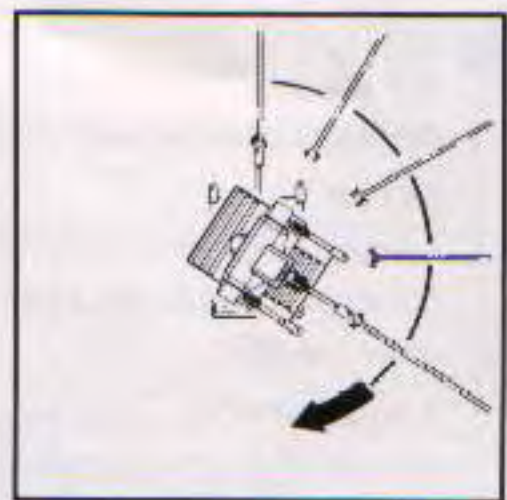

3. Ultra Spray



4. Crazy Spray

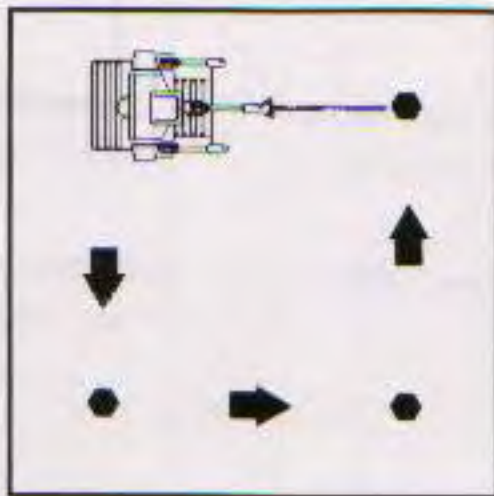

5. Box Spray

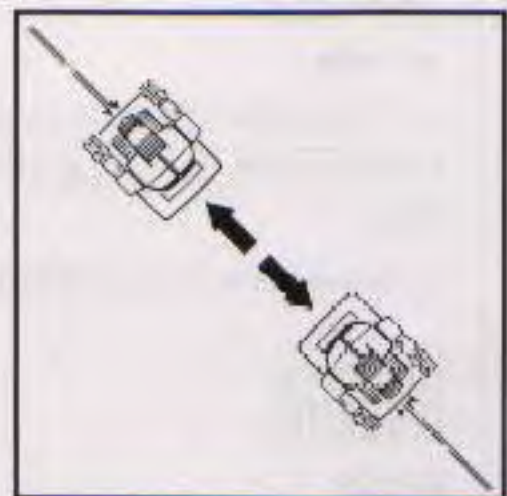

6. Sentry

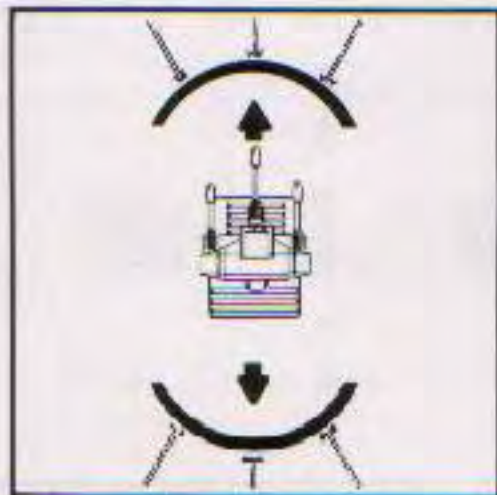

7. Sentry Spray

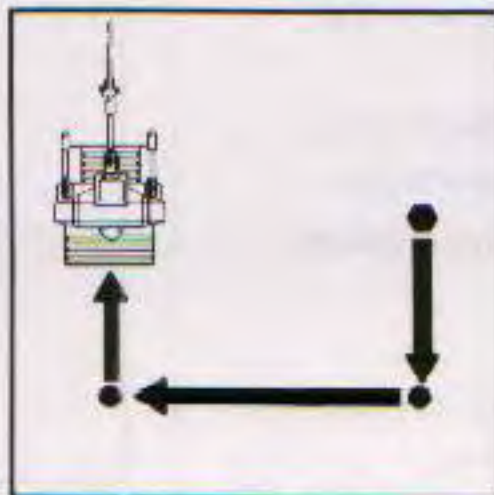

8. Flank Guard



9. Tack Advance



10. Random



NOTE: Battlefield surface conditions greatly affect PROG performance. All distance and turning information given above is approximate. PROGs perform best on a hard, flat surface.



BATTLE

(See Operations Reference Card #3)

SETUP

1. Assign a Protector PROG to one Computer Command Console and a Demon PROG to the other Console.
2. Position PROGs, facing away from each other, at opposite ends of the battlefield (4' x 6' is a good size).
3. Playing Game 2, enter the number of actions per round (1-32).

ACTION

4. Program the PROGs to maneuver into Invazer Cannon range. Blast the enemy with an Invazer Beam.
5. The winner is the first PROG to score 3 "hits."

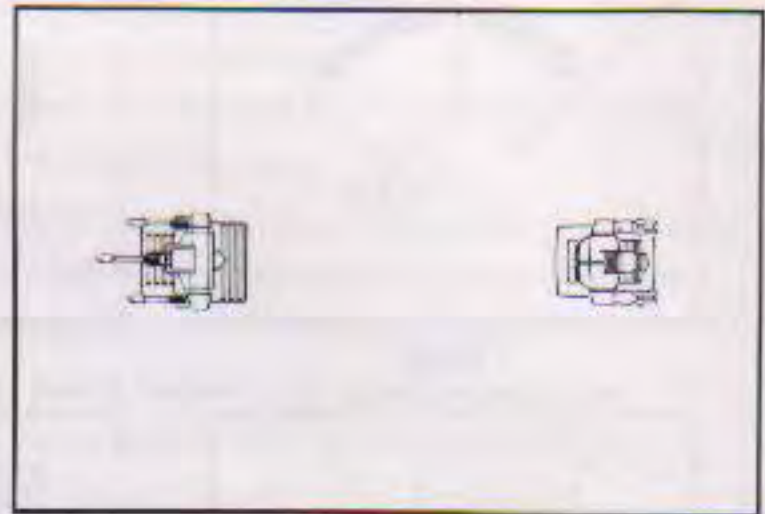

Battle

BARRIERS

SETUP

1. PROGs are positioned on both sides of the Barriers, facing away from each other, as in the Direct Control Barriers game.
2. The red side of the Barriers faces the Protector PROG. The blue side faces the Demon PROG.
3. Playing Game 2, choose the number of actions per round (1-32).

ACTION

4. Program the PROGs so they knock over the Barriers with their team's color faces up.
5. Winner is first PROG with at least 2 Barriers of its color facing up (no matter how they were knocked over).

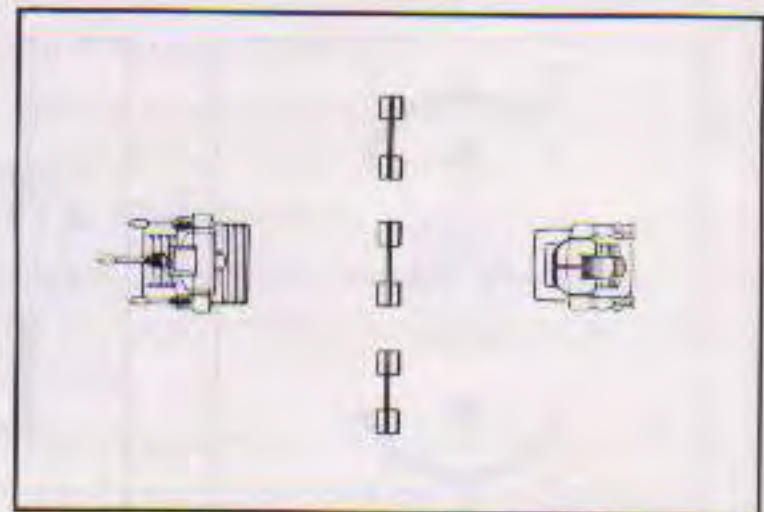

Barriers

CAPTURE THE CRYSTAL

SETUP

1. Crystal Goals are constructed at each end of the battlefield by laying a Barrier on its side, as shown.
2. Position the PROGs in front of the Barriers, facing away from each other.
3. Place one Energy Crystal in the center of the battlefield.
4. Playing Game 2, choose the number of actions per round (1-32).

ACTION

5. The winner is the first to retrieve the Energy Crystal, bring it back to the Goal, and push it into the Goal.
6. Longer games may be played by counting each goal as one point. The winner is the first to reach 10 points.

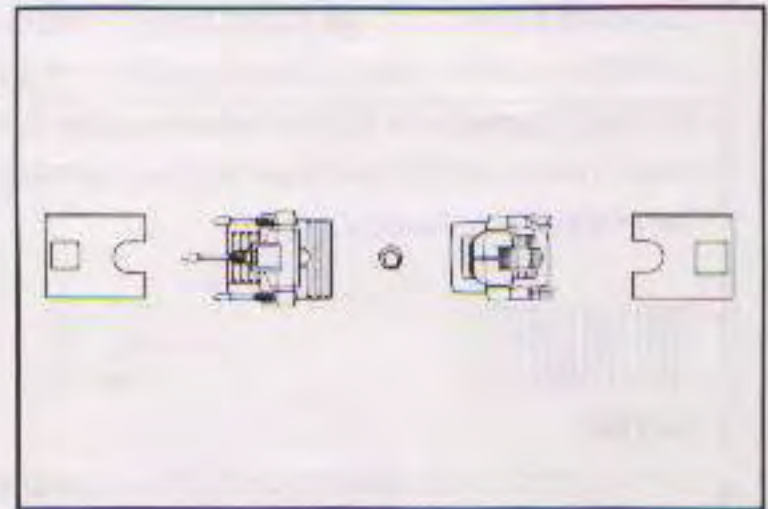

Capture the Crystal



BATTLE PATTERNS AGAINST THE COMPUTER

(See Operations Reference Card #4)

While Battle Patterns can be used as part of the tactics of a Direct Control battle, they are especially suited for solitary training sessions. One PROG (or PROGs) performs Battle Patterns under automatic control, while the player battles the PROG (or PROGs) with Direct Control.

ROUNDUP

SETUP

1. Place PROGs at opposite ends of the battlefield.
2. Place a Battle Barrier behind one of the PROGs.
3. Assign one PROG to each console.
4. Use one Console to Direct Control the PROG in front of the Battle Barrier.
5. Program the other PROG with a Battle Pattern. (Try using Patterns 5, 6, 7, 9, or 0. See "Programming Battle Patterns," pages 18, 19.)

ACTION

6. Attempt to guide the enemy PROG from its intentions and force it to run into the Battle Barrier.
7. All methods are fair game. A successful Invazer blast may stun the enemy PROG long enough for you to push it into the direction you want it to go.

PROTECTOR

SETUP

1. Place PROGs at opposite ends of the battlefield.
2. Place a Battle Barrier behind one of the PROGs.
3. Assign one PROG to each console.
4. Program the PROG in front of the Barrier with a Battle Pattern. (Try using each of the Patterns. See "Programming Battle Patterns" pages 18, 19.)
5. Use the other Console to Direct Control the other PROG.

ACTION

6. Avoid the enemy PROG, and ram the Battle Barrier.

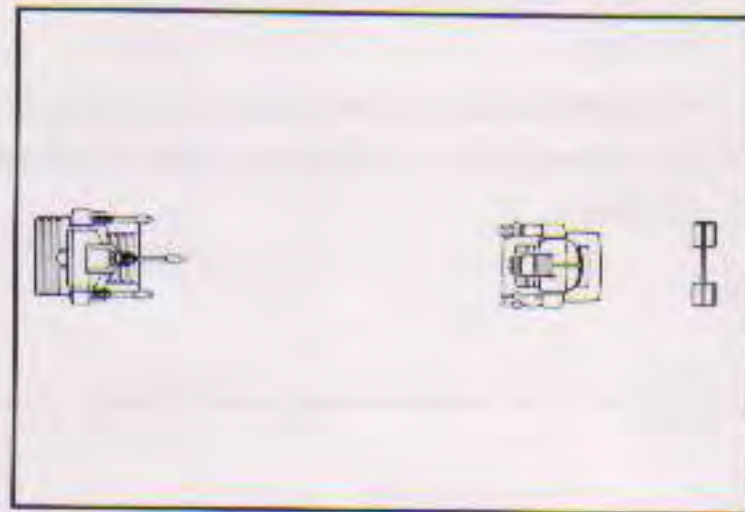

Roundup

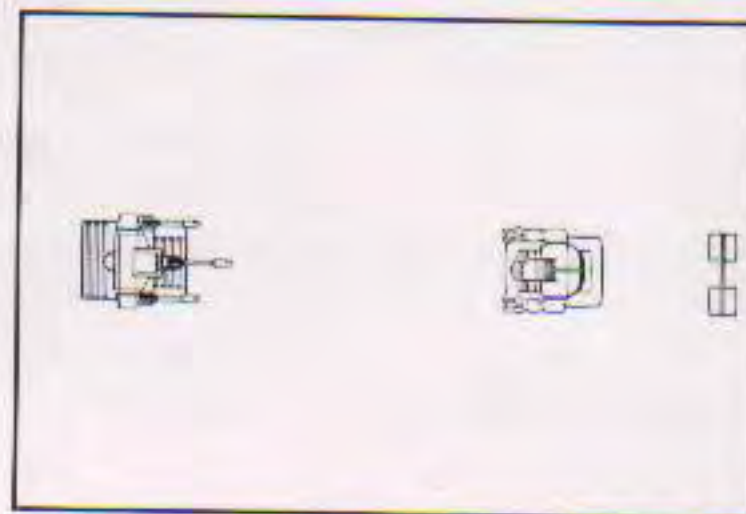

Protector



LAPS

SETUP

1. Place PROGs at opposite ends of the battlefield.
2. Place a Battle Barrier behind one of the PROGs.
3. Assign one PROG to each console.
4. Use one Console to Direct Control the PROG in front of the Battle Barrier.
5. Program the other PROG with a Battle Pattern.
(Try using each of the Patterns. See "Programming Battle Patterns" pages 18, 19.)

ACTION

6. Direct Control your PROG from end to end of the battlefield, running laps around the enemy PROG and the Battle Barrier.
7. The round is over when your PROG is hit by an Invazer beam, OR when the enemy PROG knocks over the Battle Barrier.
8. How many laps can you do without getting hit?
How fast can you do 5 laps?

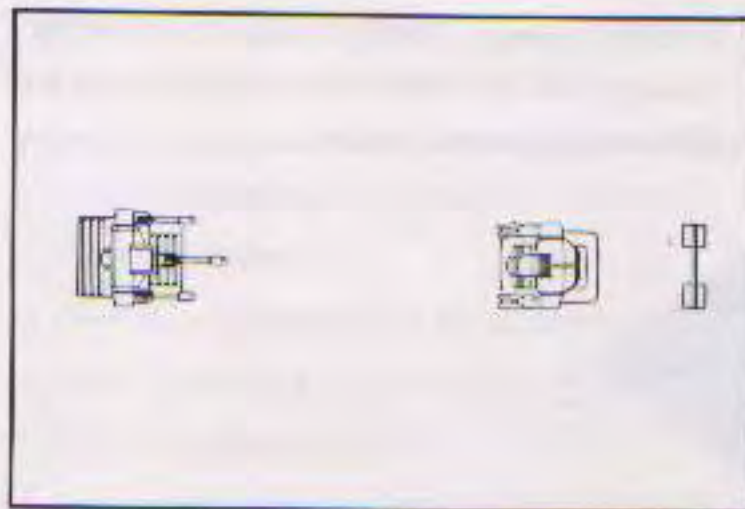

Laps

The TECHFORCE system is capable of controlling up to 8 PROGs per team, or a total of 16 PROGs, at the same time. It is in these multiple-PROG combats that the real power of TECHFORCE comes into play.

By using PROGs from another TECHFORCE set, or adding accessory PROGs to a basic TECHFORCE system, you can build PROG teams that use the following advanced features.

ASSIGNING MULTIPLE PROGS:

Assigning All PROGs to 2 Consoles:

1. Turn **Off** the Main Console and all PROGs.
2. Turn **On** all PROGs to be assigned to the *Main Console*.
3. Turn **On** the Main Console (Main Console PROGs will move).
4. Turn **On** the remaining PROGs.
5. On the Auxiliary Console, press the **Assign Key**, then the **Start Key** (Auxiliary Console PROGs will move).

Adding New PROGs to an Already Assigned Team:

NOTE: For independent control of the new PROGs, they must have separate Identification numbers set on their Drive Bases. Turn the PROGs **Off** before setting the identification number dials.

1. Turn **On** all new PROGs to be assigned to the Main Console.
2. On the Main Console, press the **Assign Key**.
3. Press the **Number Keys** of all PROGs to be assigned.
4. Press the **Start Key**.
5. Repeat for the Auxiliary Console.

Changing PROG Assignments:

To change assignment of a PROG (or PROGs) from one Console to the other Console:

1. Turn **Off** the PROG (or PROGs).
2. Turn the PROG (or PROGs) back **On**.
3. On the appropriate Console, press the **Assign** key, the appropriate **Number** key (or keys), and the **Start** key.

NOTE: If you assign 2 PROGs with the same ID number to the same console, both PROGs will react simultaneously to all commands given to that number.

MULTIPLE PROGS—DIRECT CONTROL

With all PROGs assigned to Consoles, each PROG can be individually controlled by pressing its **Number** key, then Direct Controlling it with the **Direction** keys or a joystick.

To change PROGs, simply press another **Number** key and assume Direct Control of the new PROG.

MULTIPLE PROGS—DIRECT CONTROL WITH SYNCHRONIZED PROGS

PROGs can be “chained” together to form a Synchro-Team. These teams are assigned by using the **Manual** key, and are capable of performing synchronized actions. Eight PROGs can be assigned to a Synchro-Team on each Computer Command Console.

Adding PROGs to a Synchro-Team:

With all PROGs assigned to Consoles:

1. Press the **Number** key of one PROG. (This PROG is now on the Synchro-Team.)
2. Press the **Manual** key. (This PROG is now locked in as a “follower.”)
3. Press the **Number** key of another PROG. (This PROG has been added to the team.)
4. Press the **Manual** key. (This PROG is also locked in as a “follower.”)
5. Press the **Number** key of another PROG. (This PROG has also been added to the team.)
6. Continue until your team is as large as you like.

The last PROG to be added to the Synchro-Team is the team “leader.” When the “leader” is commanded by Direct Control, the “followers” perform simultaneous, synchronized actions.

If the leader is not locked in to the Synchro-Team with the **Manual** key, the leader can be changed. To change leaders, press the **Number** of another PROG that is not already on the team. The old leader will stop and the new leader will be under Direct Control (the Synchro-Team will follow the new leader).

Removing PROGs From a Synchro-Team:

1. Press the **Number** key of the PROG to be removed from the team.
2. Press the **Clear** key.
3. Press the **Number** key of a PROG on the Synchro-Team that you wish to control.

You will now have Direct Control of that PROG, and the other PROGs will follow its lead.

MULTIPLE PROGS—DIRECT CONTROL WITH BATTLE PATTERNS

For maximum confusion to the enemy, instruct the Computer to control several PROGs in various Battle Patterns. Retain Direct Control of one PROG for responding instantly to the action.

Putting 2 or More PROGs into Battle Patterns:

1. Press the **Number** key of the chosen PROG.
2. Press the **Pattern** key.
3. Press the **Number** key of the desired pattern.
4. Press the **Number** key of another PROG.
5. Press the **Pattern** button.
6. Press the **Number** key of the desired Pattern.
7. Repeat the process for each PROG you wish to perform a Pattern.

PROGs may perform the same or different Patterns. Pressing the **Number** key of a PROG that is not performing a Battle Pattern allows Direct Control of that PROG.

To stop the PROG’s Pattern, press the **Number** key for that PROG. The PROG will now be under Direct Control.

To stop *all* Patterns, simply press the **Reset** key.

MULTIPLE PROGS—STRATEGIC PROGRAMMING

(See Operations Reference Card #5)

The differences between **Game 1** and **Game 2** come into play when there are two or more PROGs on each team.

Game 1 is called Balance because each team member is allotted an equal number of actions per round (1-6 actions per PROG).

Game 2 is called BlitzPROG because each round's actions (1-32 actions per round) can be allotted to individual PROGs in any way a player chooses. For example, with 3 PROGs on a team and 12 actions per round, each PROG could be allotted 4 actions, or one PROG could be given all 12 actions—BlitzPROG.

GAME 1—BALANCE

SETUP

1. Press the **Reset** key.
2. Press the **Game 1** key.
The green indicator light on the console will light up.
3. Enter the **Number** key for the number of actions per round.
Choose 1-6 actions.
4. Press the **Time** key (optional).
5. Press the **Number** key(s) of the new Time setting (optional—see “Changing Time Setting” on page 16).
6. Press the **Enter** key.
The Console will beep twice—“ready to accept actions.”

PROGRAMMING

7. Press the **Number** key for the PROG to be programmed.
8. Enter actions with **Direction** keys, **Pause** key, or **Fire** key.

The Console will beep once each time a key is pressed—“entry accepted.” The Console stops beeping when the maximum number of actions (1-6) has been entered.

9. Press the **Enter** key.
The Console will beep twice—“programmed for upcoming round.”

ACTION

10. Press the **Start** key.
The Console will emit three beeps. When the Start keys on both Consoles have been pressed, the PROGs on both teams will simultaneously perform the round of actions.

ALL FOLLOWING ROUNDS

For all following rounds, repeat steps 7-10 under Programming and Action above.



GAME 2—BLITZPROG

SETUP

1. Press the **Reset** key.
2. Press the **Game 2** key.
The green indicator light on the console will light up.
3. Enter the **Number** key for the number of actions per round. Choose 1-32 actions.
4. Press the **Time** key (**optional**).
5. Press the **Number** key(s) of the new Time setting (**optional**—see “Changing Time Setting” on pages 16).
6. Press the **Enter** key.
The Console will beep twice—“ready to accept actions.”

PROGRAMMING

7. Press the **Number** key for the PROG to be programmed.
8. Enter actions with **Direction** keys, **Pause** key, or **Fire** key.
The Console will beep once each time a key is pressed—“entry accepted.” The Console stops beeping when the maximum number of actions (1-32) has been entered.
9. Press the **Enter** key.
The Console will beep twice—“programmed for upcoming round.”

ACTION

10. Press the **Start** key.
The Console will emit three beeps. When the Start keys on *both* Consoles have been pressed, the PROGs on both teams will simultaneously perform the round of actions.

ALL FOLLOWING ROUNDS

For all following rounds, repeat steps **7-10** under Programming and Action above.

PROGRAMMING HINTS:

1. To repeat the same programming instructions as in the previous round, simply press the **Start** key again.
2. PROGs may be programmed in any order; you may program actions for PROG #3 before PROG #1.
3. It is OK to use fewer actions per round than the maximum allowed. For instance, in a game with 4 actions per round, a PROG can be programmed for only 2 Forward actions for a round. This PROG will perform those 2 Forward actions, then wait out the rest of the round. (To delay those 2 actions to the end of the round, press the Pause key for 2 actions, then press the Forward key for 2 actions.)

USING BATTLE PATTERNS AND DIRECT CONTROL IN STRATEGIC PROGRAMMING GAMES

Pattern or Direct Control features may be used during Multiple PROG Strategic Programming games.

IMPORTANT NOTE: Both features may not be used in the same Game. You must designate Pattern or Direct Control during the initial Game Setup.

Pattern is programmed with the **Pattern** key. Direct Control is programmed with the **Manual** key (Direct Control = Manual Control).

Programming Game 1 or Game 2 for Battle Patterns:

NOTE: Each PROG may be assigned a different Pattern.

SETUP

1. Press the **Reset** key.
2. Press the **Game 1** key or the **Game 2** key.
3. Press the **Number** key for actions per round.
4. Press the **Pattern** key.
5. Press the **Time** key (**optional**).
6. Press the **Number** key for Time setting (if you pressed Time).
7. Press the **Enter** key.

PROGRAMMING

8. Press the **Number** key for a PROG.
9. Press the **Pattern** key.
(Each PROG may perform programmed moves or a Pattern.)
10. Press the **Number** key for the desired Pattern.
11. Press the **Enter** key.
12. Repeat steps 8-10 for each PROG that is to perform Battle Patterns.
13. Use regular Strategic Programming steps to program the actions of the other PROGS.

ACTION

14. Press the **Start** key.

When both **Start** keys have been pressed, the round will begin. For all following rounds repeat Steps 8-14.

Programming Game 1 or Game 2 for Direct Control:

NOTE: Putting more than one PROG under Direct Control creates a Synchro-Team.

SETUP

1. Press the **Reset** key.
2. Press the **Game 1** key or the **Game 2** key.
3. Press the **Number** key for moves per round.
4. Press the **Manual** key.
5. Press the **Time** key (**optional**).
6. Press the **Number** key for Time setting (if you pressed Time).
7. Press the **Enter** key.

PROGRAMMING

8. Press the **Number** key for a PROG.
9. Press the **Manual** key.
10. Press the **Enter** key.
11. Repeat steps 8-10 for each PROG that is to join the Synchro-Team.
12. Use regular Strategic Programming steps to program the actions of the other PROGS.

ACTION

13. Press the **Start** key.
14. Use the **Direction** and **Fire** keys to control the PROGS that are under Direct Control.

ALL FOLLOWING ROUNDS

For all following rounds, repeat steps 8-14 under Programming and Action above.

BATTLE

(See Operations Reference Card #5)

SETUP

1. Assign all Protector PROGs to one Console and all Demon PROGs to the other console. (See Assigning Multiple PROGs, page 24.)
2. Take turns placing PROGs on the battlefield, in any position you want.
3. Play Game 1, choosing 4 to 6 actions per PROG. (See Strategic Programming with Multiple PROGs, page 26.)

ACTION

1. Program PROGs to maneuver into Invazer range. Blast the enemy with Invazer Beams.
2. When a PROG is stunned with an Invazer Beam, it must be removed from the battlefield and turned off.
3. Winner is first PROG to stun all its opponent's PROGs.

CAPTURE THE CRYSTAL

(See Operations Reference Card #5)

SETUP

1. Crystal Goals are constructed at each end of the battlefield by laying a Barrier on its side.
2. Take turns placing PROGs on the battlefield, in any position you want.
3. Place one Energy Crystal in the center of the battlefield.
4. Play Game 2, choosing 1 to 32 actions per round.

ACTION

5. Winner is the first PROG to retrieve the Energy Crystal, bring it back to the Goal, and push it into the Goal.
6. Longer games may be played by counting each goal as one point. The winner is the first to reach 10 points.

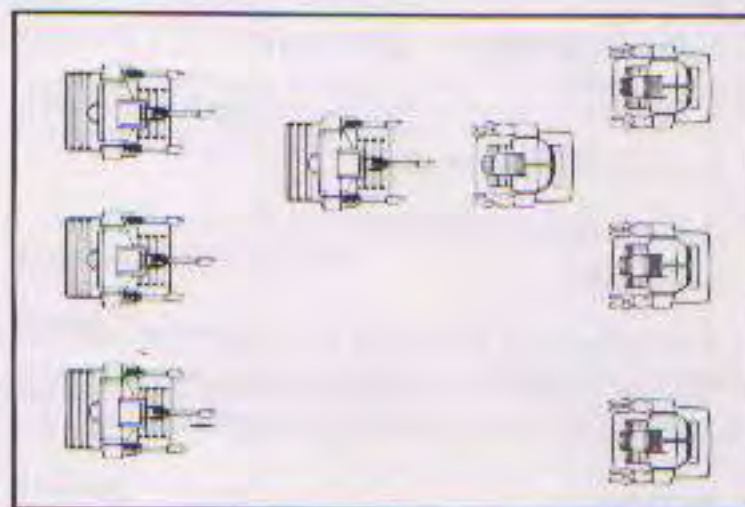

Battle

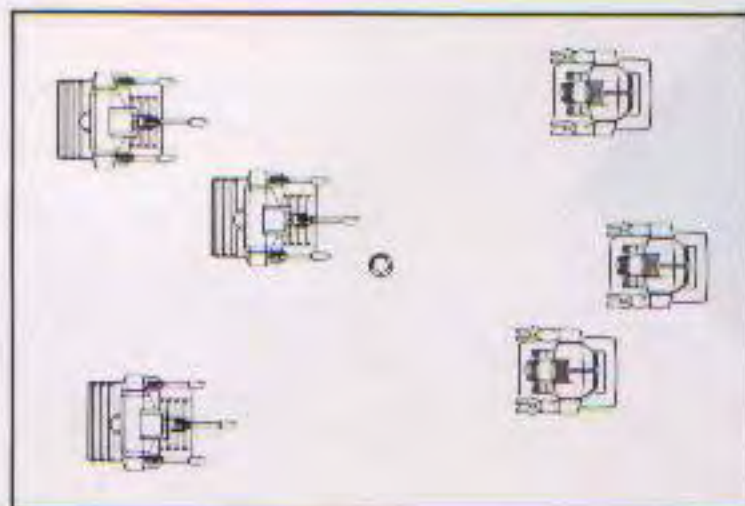

Capture the Crystal

DESTROY THE CRYSTAL

(See Operations Reference Card #5)

SETUP

1. Assign all Protector PROGs to one Console and all Demon PROGs to the other console. (See Assigning Multiple PROGs, page 24.)
2. Take turns placing PROGs on the battlefield, in any position you want.
3. Place one Energy Crystal at each end of the battlefield.
4. Play Game 2, choosing 1 to 32 actions per round. (See Multiple PROG Strategic Programming, page 27.)

ACTION

1. Winner is the first PROG to destroy his opponent's Energy Crystal by touching it.



Destroy the Crystal



IMPORTANT SYSTEM NOTES:

1. FEEDBACK BEEPS:

When you press a keyboard key, the Computer Command Console will emit feedback beep(s) to let you know that it has received the entry.

- **Single Beep (*):**

The Console will emit 1 beep (*) when you press any key on the keyboard except Enter, Start, or Direction keys (unless programming).

- **Double Beep (**):**

The Console will emit 2 beeps (**) when you press Enter.

- **Triple Beep (***):**

The Console will emit 3 beeps (***) when you press Start.

- **Error Beep (°):**

The console will emit a long error beep (°) when you have entered an invalid command in Strategic Programming. When you hear the error beep, you must re-do that entry.

Assigning PROGs:

- The Console will beep (*) when you press Assign, and number keys.
- The Console will emit 3 beeps (***) when you press Start.

Direct Control:

- The Console will beep (*) when you press any key except direction keys.

Programming:

- The Console will emit one beep (*) when you press Game 1/Manual, Game 2/Pattern, number keys, Time, Clear, and direction keys.
- The Console will emit 2 beeps (**) when you press Enter.
- The Console will emit 3 beeps (***) when you press Start.
- The Console will emit 2 beeps (**) at the end of each round.

When entering moves for a PROG, the Console will beep every time you press a direction key until all the moves for that PROG have been entered.

NOTE: When you do not hear a feedback beep (except when pressing direction keys in Direct Control mode), the computer is not accepting the command because you are pressing the keys in the wrong order.

NOTE: When the system has been left on but is not used for approximately 10 minutes, the Main Console will begin beeping intermittently until you either turn it off or press one of its keys.

2. INDICATOR LIGHTS:

Power:

The red power indicator light on the Main Console will go on whenever the power switch is turned ON.

Action:

- The green action indicator lights on both Consoles will blink when PROGs are performing an action. In Direct Control, it will blink when a PROG number has been pressed and that PROG is ready to perform an action.
- The action light will stay on when the Console is waiting for a command.
- The action light will be off when the Console has been reset and its memory is clear.
- The action lights will blink quickly and then go off when you turn the Consoles on.



3. HIT LIGHTS (on PROGs):

- The Hit Lights on a PROG blink when the PROG has been hit with an Invazer Beam. The lights will continue blinking as long as the PROG is disabled.
- The Hit Lights will also go on when a PROG is being Directly controlled or is firing his Invazer Cannon.

4. INVAZER BEAMS:

The Invazer Cannons in the Drives Bases have a maximum range of 4-5 ft.

They also have a reflecting range of up to 1 ft. Sometimes, when a PROG fires his Invazer Beam directly at an object less than 1 ft. away, the beam will be reflected into his own cannon and he will stun himself.

When a PROG is firing his Invazer Beam, the Drive Base will emit a firing tone, and the red Invazer light on the front of the Drive Base and the hit lights on the PROG will go on. When you try to fire and there is no firing tone, and/or the hit lights on the PROG do not go on, the PROG Figure is not making good contact with the Drive Base and should be re-mounted.

IMPORTANT NOTE: *Invazer Cannons Will Not Work Unless Drive Base Is Covered With a PROG Figure or a Drive Base Cap.*

5. RESET KEY:

The **Reset** key erases everything from the Console's memory except PROG assignments.

When starting a new operation, it is a good idea to first press **Reset**. This will erase all previous entries, minimizing the chance of making mistakes.

Remember: *After pressing Reset, a PROG number must be pressed to give you Direct Control of that PROG.*

Press the Reset key before programming Games.



Demon Hit Lights

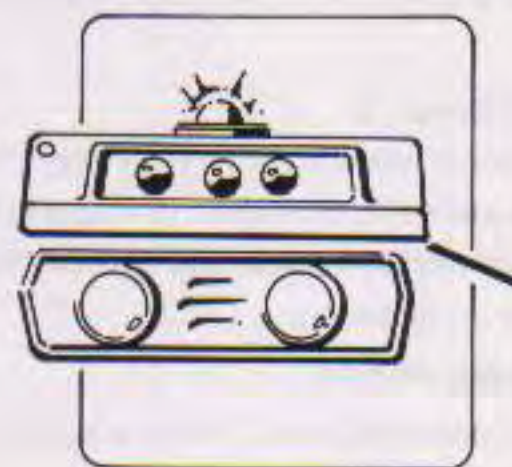

Protector Hit Lights



TROUBLESHOOTING

1. Main Console fails to beep when you turn it on.

1. Are batteries inserted correctly?
2. Are batteries fresh?

2. Main Console does not respond with beeps when you press keys.

1. Is the Console turned on?
2. Is console waiting for a "start" or "enter" command?
3. Try pressing "Reset."

3. Auxiliary Console does not respond with beeps when you press keys.

1. Is the Console Connector Cable plugged into the correct ports?
2. Is the Main Console turned on?
3. Try pressing "Reset."

4. PROGs move randomly or don't follow commands.

1. Is Main Console antenna fully extended?
2. Are PROGs turned on? Are batteries fresh?
3. Do not operate TECHFORCE near other radio controlled objects or large masses of metal. Sometimes these objects will interfere with the TECHFORCE signal.

5. PROGs don't respond to "Assign" commands (by moving back and forth).

1. Are PROGs turned on?
2. Are you using the correct PROG number, as set on the bottom of the Drive Bases?
3. Try turning PROGs off and then back on. Once PROGs are assigned to a console, they will only respond to that console.

6. PROGs don't respond to commands.

1. Are PROGs correctly assigned? Are batteries fresh?
2. Is the Main Console antenna fully extended?
3. Are you using the correct PROG number, as a set on the bottom of the Drive Bases?

7. PROGs always move in unison.

1. Are PROGs set to different numbers with the dial under the drive base?
2. Press "Reset" if you were controlling a synchro-team previously.

8. Invazer cannons don't work (PROGs are not stunned when fired directly upon).

1. Are PROGs firmly attached to drive bases?
2. If using drive bases without PROG figures, are drive bases covered with Drive Base Caps?
3. Are Drive Base batteries fresh?

9. Console does not respond to Game setup commands.

1. Are both consoles in a game mode?
2. Did you press "Start" on both consoles?

10. PROGs don't move when "Start" is pressed.

1. Are you using the correct PROG number, as set on the bottom of the Drive Bases?
2. Make sure Game setup has been entered correctly.

11. PROGs don't perform Battle Patterns.

1. Are both consoles out of game mode?
2. Try pressing Reset.

SYSTEM EXPANSION

Expand Your TECHFORCE™ Set with these TECHFORCE™ accessories:

Drive Bases.

PROG™ Figures.

Sonic Decoder™ and TECHFORCE Adventure Tapes.

Play TECHFORCE Adventure Tapes (one Tape included with Sonic Decoder) in your cassette player. The Axlon Sonic Decoder turns encoded tones into commands for one team of PROGs. Play against the Adventure Tape—Available in 1987.

Also look for new PROG Figures and the TECHFORCE playset. All new PROG figures will be compatible with your TECHFORCE Set.

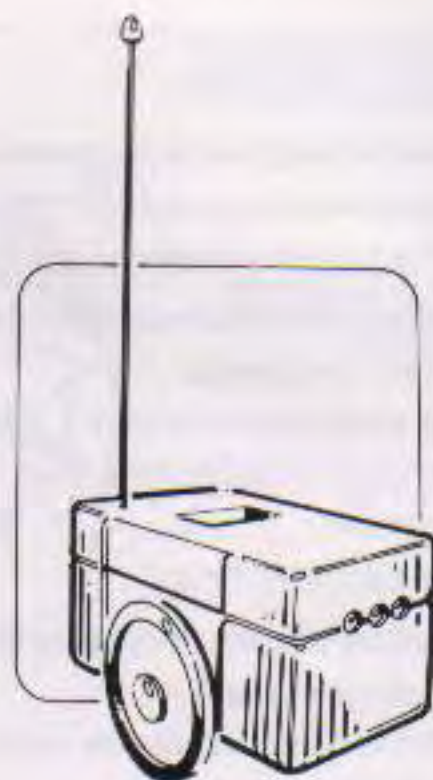

Motorized Drive Bases

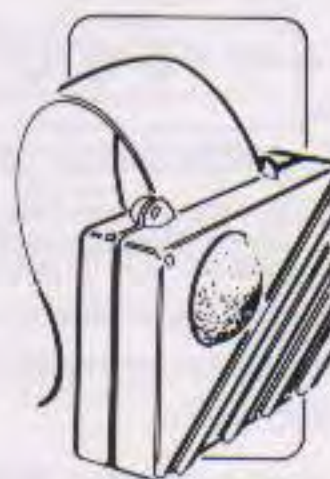

Sonic Decoder

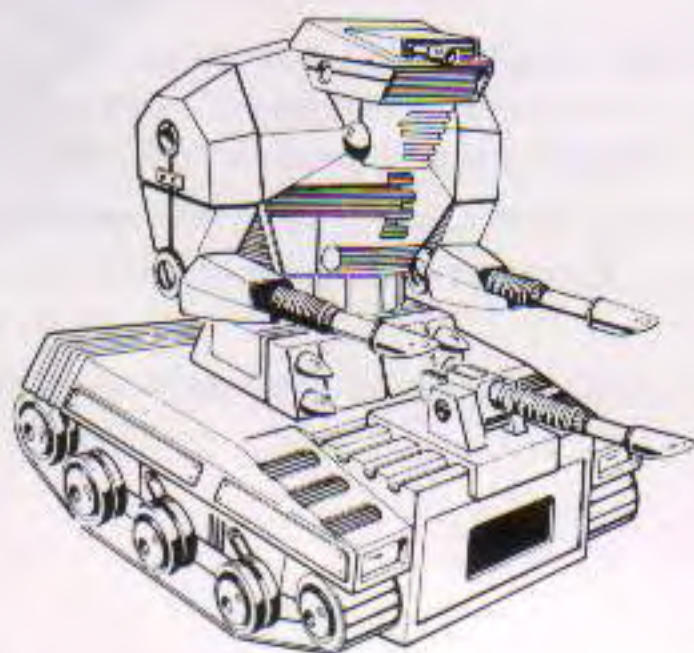

PROG-Protector

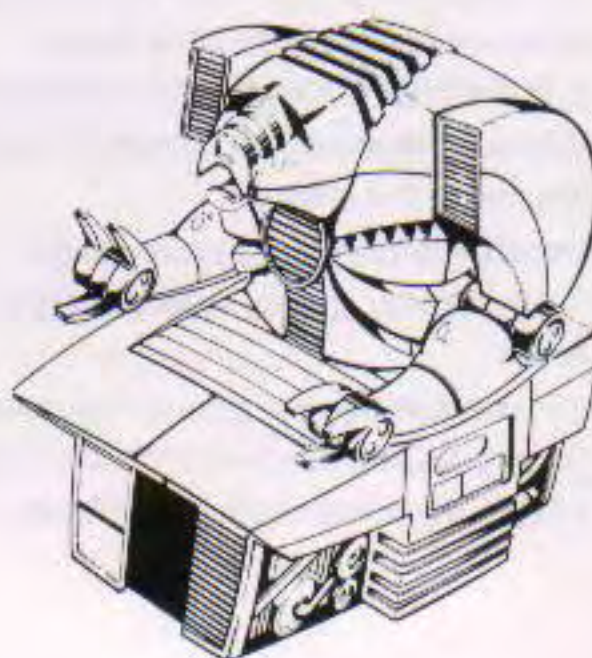

PROG-Demon



WARRANTY INFORMATION

Warranty is only valid if you complete and send back the enclosed warranty card.

AXLON, Inc. warrants the TECHFORCE Computer Command Consoles, Drive Bases, Drive Base Caps, and PROG figures, given normal and reasonable use, to be free from defects in workmanship or materials for 90 days after the original date of purchase.

AXLON, Inc. shall not be liable under this or any implied warranty for incidental or consequential damages. The duration of any implied warranties shall be limited to 90 days after the date of purchase.

Some states do not allow limitations to be placed on the length of an implied warranty or exclusions or limitations of incidental or consequential damages, so the above exclusions or limitations may not apply to you.

This warranty gives you specific legal rights that may vary from state to state. Applicable in the U.S.A. only.

DATED PROOF OF PURCHASE MUST ACCOMPANY RETURNED PRODUCTS.

Send to:

Quality Control Dept.
Axlon, Inc.
1287 Lawrence Station Rd.
Sunnyvale, CA, 94089

