

Ages 3 & U

Includes Talking Alphie and 4 durable 2-sided plastic activity cards  
Phillips® screwdriver needed to insert batteries and replace light bulb

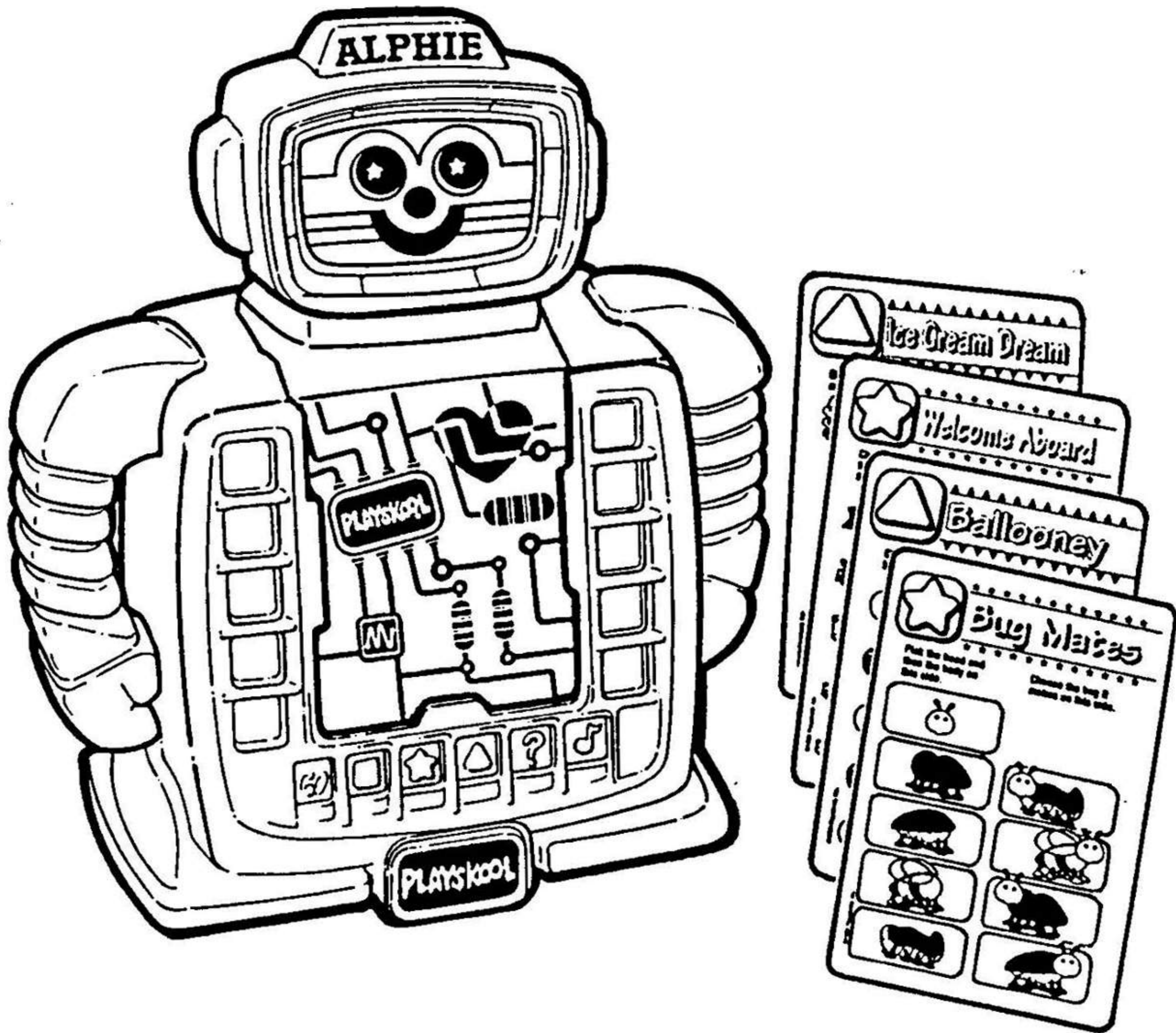

# Talking Alphie®



## HOW TO INSERT BATTERIES:

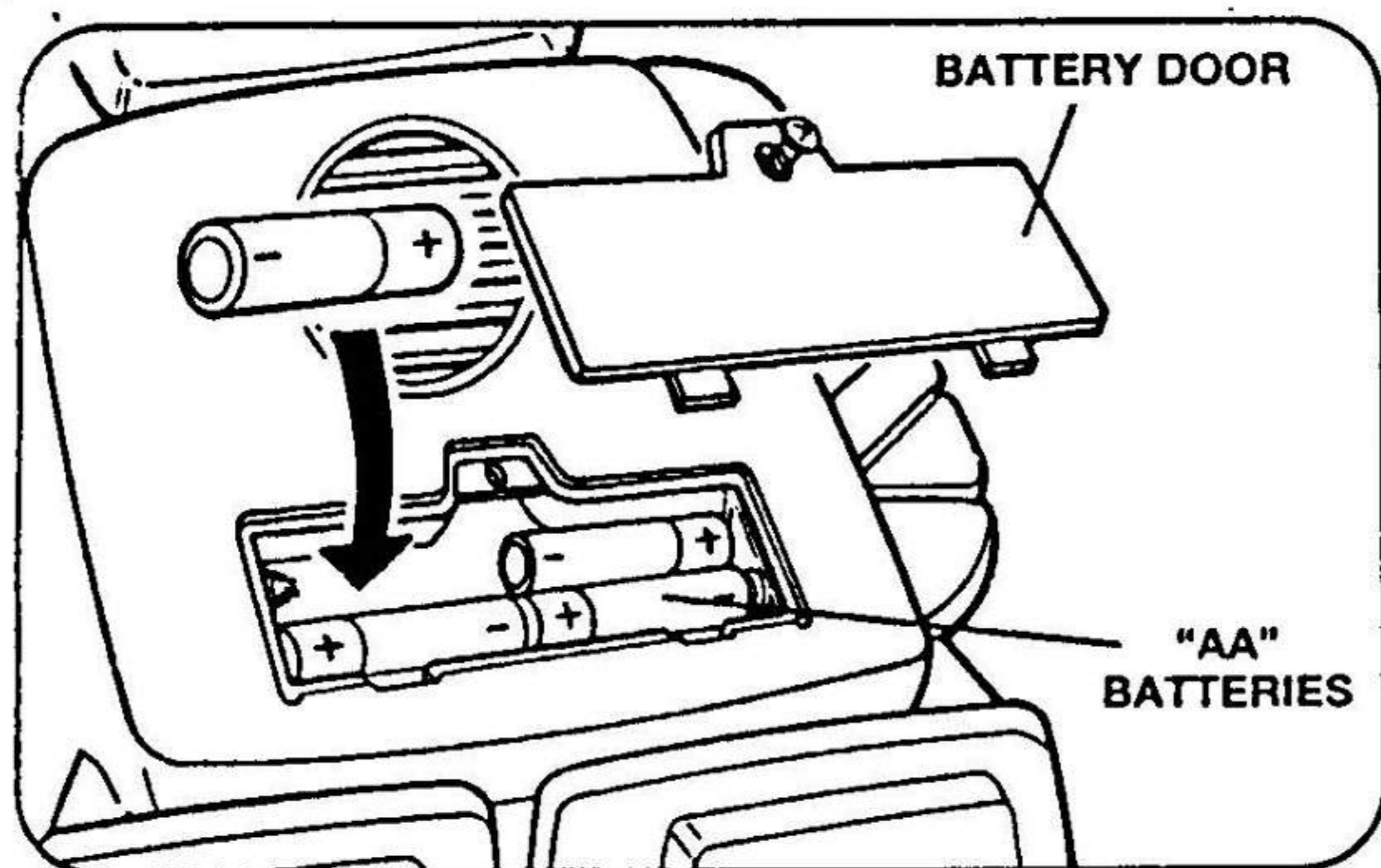

### CAUTION: TO AVOID BATTERY LEAKAGE

1. Be sure to insert the batteries correctly and always follow the toy and battery manufacturers' instructions.
2. Never mix old batteries and new batteries, or standard (carbon-zinc) with alkaline batteries.
3. Always remove exhausted or dead batteries from the product.
4. Remove batteries if product is stored for a long period of time.

1. Using a Phillips® screwdriver, loosen screw and remove battery compartment door.
2. Insert 4 fresh "AA" alkaline batteries into battery compartment as shown.
3. Replace battery compartment door and tighten screw.

## REPLACING BATTERIES

If Alphie speeds up, acts erratically, or stops working, check for proper battery connection. Batteries may need to be replaced.

## TO REPLACE LIGHT BULB

1. When Alphie's face does not light up, the light bulb in his head needs to be replaced. Replace the bulb with a miniature bayonet-type base light bulb #503, #47, or #44. (You can call Playskool at 1-800-PLAYSKL to order a replacement bulb.)
2. Using a Phillips® screwdriver, loosen screw in door on back of Alphie's head, and remove door.
3. Grasp light bulb inside head, press down and turn light bulb a quarter turn in a counterclockwise direction, and pull light bulb out of socket.
4. Insert new light bulb into socket and press down on light bulb to fit it firmly into socket. Turn light bulb slightly in a clockwise direction.
5. Replace door and tighten screw.

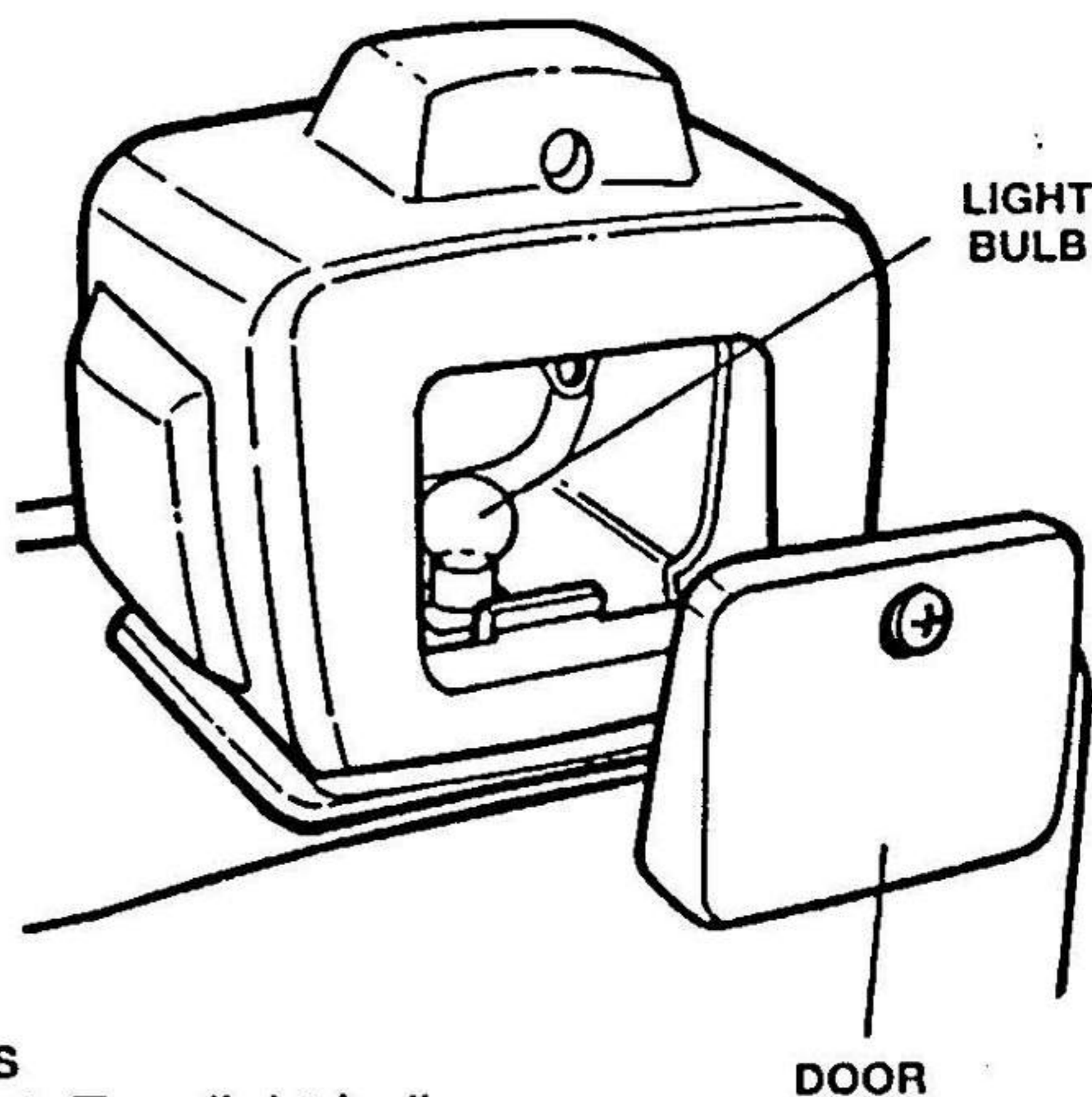









## HOW TO PLAY WITH TALKING ALPHIE:

1. To start Alphie, press the green "GO" button. If Alphie is off when you press "GO," he will make a musical sound, say "Hi, I'm Alphie," and tell you how to begin playing an activity. Also, his face will light up to show he is on. If Alphie is on when you press "GO," he tells you he's already on and repeats his directions to begin activity.

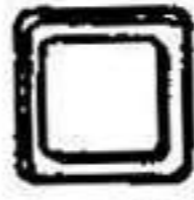
2. To begin an activity, insert an activity card into Alphie. Press the shape button that matches the shape shown on the card. This tells Alphie which activity you want to play.
3. After you press a shape button, Alphie makes a musical sound and gives you general directions on how to play the activity. You can also read the instructions for more specific instructions on how to play the activity.
4. To choose a picture on the left side of the card, press the red square next to the picture. To select a picture on the right side of the card, press the yellow square next to the picture. Follow Alphie's directions to play the activity, pressing the red or yellow buttons.
5. As you play the activity, Alphie responds to your choices. When you choose correct answers, he says "You're right" or another positive phrase. For incorrect answers, Alphie "quacks" or "boings" and encourages you to try again.
6. You can play two different activities with the "Play a Song" activity card. Press the "question mark" shape button to play a guessing game with Alphie: Can you find the tune that he plays? Press the "musical note" shape button and Alphie plays songs for you. For both activities, you can press any of the red or yellow buttons to make your selections.
7. Always wait until Alphie finishes speaking or making sounds before pressing a button.
8. If you do not press any buttons, Alphie will repeat his directions. He will repeat directions 3 times, pausing each time to allow you to respond. If you do not respond after the third time, Alphie waits 2-3 minutes more, then he makes a musical sound, says "Bye-bye" and automatically shuts off.

---

### ACTIVITIES YOU CAN PLAY WITH TALKING ALPHIE USING THE ACTIVITY CARDS INCLUDED:

<u>NAME OF ACTIVITY</u>	<u>PRESS THIS SHAPE BUTTON TO PLAY</u>	<u>TYPE OF ACTIVITY</u>
Bug Mates		Picture Addition
Shape Match		Matching, Identifying Shapes
Finger Count		Counting, Matching
Welcome Aboard		Picture Addition
Play a Song	 	Melodies, Identifying Songs
Ballooney		Sequencing, Identifying Colors
Ice Cream Dream		Sequencing, Identifying Colors
Count the Stars		Counting, Matching

---

## **SPECIAL NOTES:**

1. Press "GO" to start Alphie. Then press the appropriate shape button to tell Alphie which activity you want to play.
2. Press and release the buttons. Do not keep continuous pressure on them.
3. For extra stability, hold Alphie's arm handle with one hand while pressing buttons.
4. Sand, dirt and water will damage Alphie and his cards.
5. Store all cards in Alphie's card slide area when not in use, to avoid misplacing them.

## **COLLECT TALKING ALPHIE ACTIVITY SETS AND ADD TO THE LEARNING FUN!**

Each set has 6 activities and 2 games, and is designed to be used with Talking Alphie. These sets have two progressive learning levels to help children develop basic learning skills as they play! Level One uses colorful pictures to teach basic concepts, and help kids identify colors, shapes and objects. Level Two builds upon the concepts learned in Level One using pictures, numbers, letters and simple words. Each set sold separately. Sets are also compatible with Alphie® II.

### **FCC STATEMENT**

This equipment generates, uses, and can radiate radio frequency energy and, if not installed and used in accordance with the instructions, may cause interference to television or radio reception. It has been tested and found to comply with the limits for a Class B digital device, pursuant to Part 15 of the FCC Rules. These limits are designed to provide reasonable protection against harmful interference in a residential installation. However, there is no guarantee that interference will not occur in a particular installation. If this toy does cause harmful interference to radio or television reception, which can be determined by turning the equipment off and on, the user is encouraged to try to correct the interference by one or more of the following measures:

- Reorient or relocate the receiving antenna.
- Increase the separation between the equipment and receiver.
- Consult the dealer or an experienced radio/TV technician for help.

Changes or modifications to this unit not expressly approved by the party responsible for compliance could void the user's authority to operate the equipment.

©1993 Playskool, Inc., Pawtucket, RI 02862 USA, a subsidiary of Hasbro, Inc. All Rights Reserved.

®denotes Reg. U.S. Pat. & TM Office.

**MADE IN CHINA.**

47 P/N 44917200

---